



Input RFI Filters

The Input RFI Filter units are designed to be used with the following Allen-Bradley Adjustable Frequency AC Drives:

- 1305
- 1336 PLUS
- 1336 PLUS II
- 1336 FORCE™
- 1336 IMPACT™

The main function of the input RFI filter is to reduce the radio frequency conducted emissions into the main supply lines and ground wiring. This publication provides the steps needed to install the filter.

Important: Declarations of Conformity to the European Union Directives are available for Allen-Bradley AC Drive Products. Please contact your Allen-Bradley Sales Representative.



ATTENTION: The Input RFI Filter connects between the incoming AC supply line and the drive input terminals. The filter must be installed by qualified personnel familiar with the drive and associated machinery. Failure to comply may result in personal injury and/or equipment damage.



ATTENTION: An incorrectly applied or installed Input RFI Filter can result in component damage or a reduction in product life. Wiring or application errors, such as incorrect wiring layout, incorrect or inadequate AC supply or excessive ambient temperatures may result in malfunction of the system.

Refer to the page listed below for installation instructions.

- 1305 - See [page 2](#)
- 1336 PLUS/PLUS II, FORCE and IMPACT - See [page 5](#)

1305 Filter Installation

Use the cross reference below to verify that the correct filter and kit have been selected for your CE compatible drive.

Important: Do not use the filters listed below in single-phase applications. Consult factory for further information.

Filter Selection

Filter Catalog Number	Power Dissipation	Three-Phase Volts	Used with . . .	Metal Conduit Panel Kit Catalog Number
1305-RFB-05-A	4.2 Watts	200-240V	1305-AA02A, AA03A	1305-MP-05-A
			1305-AA04A	1305-MP-06-A
1305-RFB-08-B	8.8 Watts	200-480V	1305-AA08A, BA01A, BA02A, BA03A, BA04A, BA06A	1305-MP-08-B
1305-RFB-12-C	10.3 Watts	200-480V	1305-AA12A, BA09A	1305-MP-12-C

Components Supplied

Item	Quantity
Filter w/Output Cable	1
Grounding Bracket	1
Metal Conduit Panel	1
Terminal Block Cover	1
Terminal Block Cover Adapter	1
Terminal Block Cover Nut	2
Hex Standoff	2

Filter Dimensions

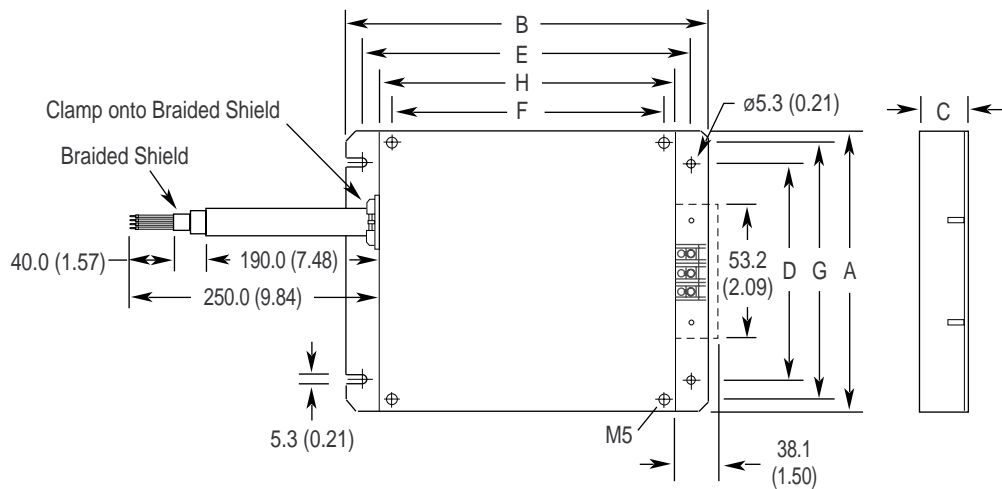

All Dimensions in Millimeters and (Inches)

Catalog Number	A	B	C	D	E	F	G	H	Weight kg (lbs.)
1305-RFB-5-A	122.0 (4.80)	235.0 (9.25)	40.5 (1.59)	90.0 (3.54)	215.0 (8.46)	180.0 (7.09)	110.0 (4.33)	195.0 (7.68)	0.85 (1.87)
1305-RFB-8-B	172.0 (6.77)	235.0 (9.25)	40.5 (1.59)	140.0 (5.51)	215.0 (8.46)	180.0 (7.09)	160.0 (6.30)	195.0 (7.68)	0.95 (2.09)
1305-RFB-12-C	212.0 (8.35)	235.0 (9.25)	42.0 (1.65)	180.0 (7.09)	215.0 (8.46)	180.0 (7.09)	200.0 (7.87)	195.0 (7.68)	1.05 (2.31)



ATTENTION: To prevent electrical shock, disconnect the power source before installing or servicing.

1. Mount the filter to the panel. Refer to the Dimension drawing shown on the previous page.
2. Remove and discard the plastic conduit panel of the 1305. Replace with the supplied metal conduit panel.
3. Mount the grounding bracket to the conduit panel of the drive using the supplied hardware.
4. Using the figure below as guide, mount the drive to the filter.

Filter Mounting

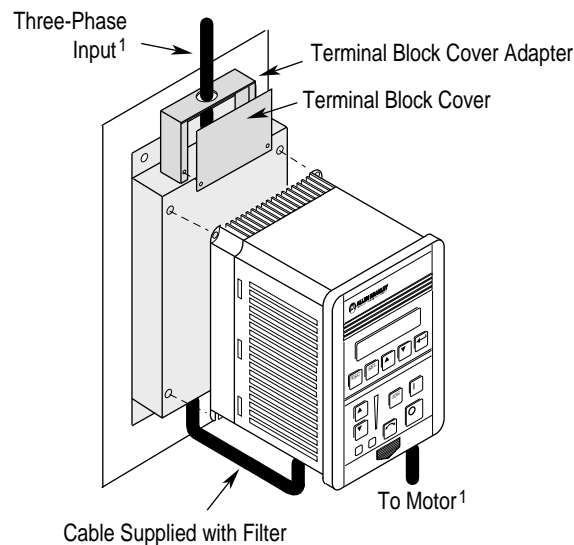

¹ Input power (source to filter) and output power (filter to drive and drive to motor) wiring must be in conduit or have shielding/armor with equivalent attenuation. Shielding/armor must be bonded to the metal conduit panel.

5. The RFI filter must be connected between the incoming AC supply line and the drive input terminals.

Important: The filter may cause ground leakage currents. Therefore a solid ground connection must be provided as shown on the following page.

(NEMA Type 1 only) Before connecting the AC input lines, slide the Terminal Block Cover Adapter onto the wire. After wiring has been completed, slide the adapter up to the filter and secure with supplied standoffs. Place cover over adapter and secure with supplied hardware.



ATTENTION: To guard against possible equipment damage, RFI filters can only be used with AC supplies that are nominally balanced with respect to ground. In some installations, three-phase supplies are occasionally connected in a 3-wire configuration with one phase grounded (Grounded Delta). The filter must not be used in Grounded Delta supplies.

Filter Wiring - 1305

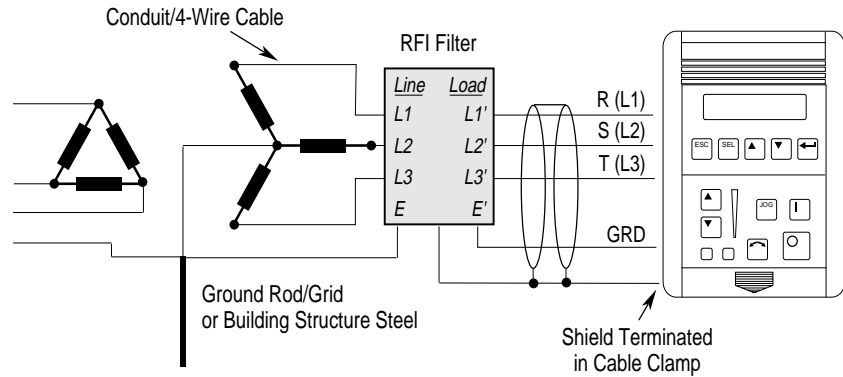

6. Connect remaining wires. Cables must use knockouts defined in the figure below.
7. To assure that the RFI filter is effective and to reduce cable radiation, the motor cable must be shielded or armored. The ground conductor of the motor cable (drive end) must be connected directly to the drive ground terminal, not to the enclosure bus bar. The shield must be bonded to the metal where the motor cable exits the drive. At the motor end, the ground conductor should also be connected to the motor case ground. The shield or armor must be bonded to the filter (and drive). At the motor end, the shield should also be connected to the motor case ground.

1305 Knockout Definitions

Dimensions are in Millimeters and (Inches)

Frame A

(1305-AA02A, AA03A, AA04A)

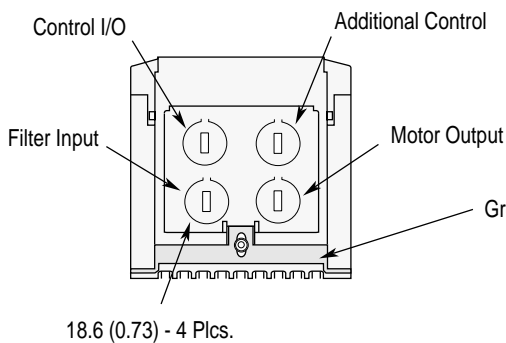

Frames B and C

(1305-AA08A, AA12A, BA01A, BA02A, BA03A, BA04A, BA06A, BA09A)

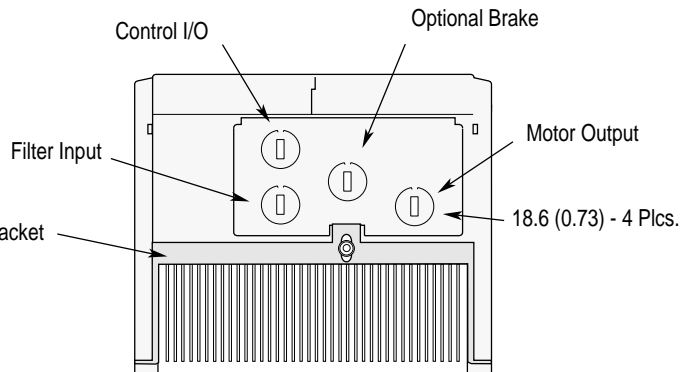

1336 PLUS, PLUS II, FORCE and IMPACT Filter Installation

Use the cross reference below to verify that the correct filter has been selected for your CE compatible drive. In addition, ensure that the drive was ordered with the “-AE” enclosure option or the EMC Enclosure Kit (1336x-AEx) has been properly installed.

Filter Selection

Filter Catalog Number	Filter Series	Mounting See . . . (pg. 11-13)	Power Diss. (Watts)	Three-Phase Volts	Used with . . .			Frame Ref.	
					1336 PLUS/PLUS II	1336 FORCE	1336 IMPACT		
1336-RFB-7-AA	A	Figure 1	4.5	200-240V 380-480V	1336S/F-AQF05 - AQF10 1336S/F-BRF05 - BRF20	N/A	1336E-AQF05 - AQF10 1336E-BRF05 - BRF20	A1 A1-A2	
1336-RFB-7-A	B	Figure 1 or Figure 2	2	200-240V 380-480V	1336S/F-AQF05 - AQF10 1336S/F-BRF05 - BRF20		1336E-AQF05 - AQF10 1336E-BRF05 - BRF20	A1 A1-A2	
1336-RFB-16-AA	A	Figure 1	9	200-240V 380-480V	1336S/F-AQF15 - AQF20 1336S/F-BRF30 - BRF50		1336E-AQF15 - AQF20 1336E-BRF30 - BRF50	A2 A2-A3	
1336-RFB-16-A	B	Figure 1 or Figure 2	9.5	200-240V 380-480V	1336S/F-AQF15 - AQF20 1336S/F-BRF30 - BRF50		1336E-AQF15 - AQF20 1336E-BRF30 - BRF50	A2 A2-A3	
1336-RFB-30-A	A	Figure 1	14	200-240V	1336S/F-AQF30 - AQF50		1336E-AQF30 - AQF50	A3	
1336-RFB-30-A4	A	Figure 2	35	380-480V	1336S/F-BRF75 - BRF200		1336E-BRF75 - BRF100	A4	
1336-RFB-27-B	A	Figure 2	30	200-240V 380-480V	1336S/F-A007 1336S/F-B007 - B015		1336T-A001 - A007 1336T-B001 - B015	1336E-A007 1336E-B007 - B015	B B
1336-RFB-48-B	A	Figure 2	56	200-240V 380-480V	1336S/F-A010 - A015 1336S/F-B020 - B030		1336T-A010 - A015 1336T-B020 - B030	1336E-A010 - A015 1336E-B020 - B030	B B
1336-RFB-80-C	A	Figure 2	71	200-240V 380-480V	1336S/F-A020 - A030 1336S/F-BX040 - BX060		1336T-A020 - A030 1336T-BX040 - BX060	1336E-A020 - A030 1336E-BX040 - BX060	C C
1336-RFB-150-D	A	Figure 3 or Figure 4	90	200-240V 380-480V	1336S/F-A040 - A050 1336S/F-B060 - B100		1336T-A040 - A050 1336T-B060 - B100	1336E-A040 - A050 1336E-B060 - B100	D D
1336-RFB-180-D	A	Figure 3 or Figure 4	125	200-240V 380-480V	1336S/F-A060 1336S/F-B125 - BX150	1336T-A060 1336T-B125 - BX150	1336E-A060 1336E-B125 - BX150	D D	
1336-RFB-340-E	A	Figure 3 or Figure 4	60	200-240V 380-480V	1336S/F-A075 - A125 1336S/F-B150 - B250	1336T-A075 - A125 1336T-B150 - B250	1336E-A075 - A125 1336E-B150 - B250	E E	
1336-RFB-475-G	A	Figure 5	61	380-480V	1336S/F-BP250 - BP350 1336F-BPR250 - BPR350 1336S/F-BX250 - B350	N/A 1336T-BX250 - B350	1336E-BP300 - BP350 1336E-BPR300 - BPR350 1336E-BX250 - B350	F G	
1336-RFB-590-G	A	Figure 5	94	380-480V	1336S/F-BP400 - BP450 1336F-BPR400 - BPR450 1336S/F-B400 - B450	N/A 1336T-B400 - B450	1336E-BP400 - BP450 1336E-BPR400 - BPR450 1336E-B400 - B450	F G	
1336-RFB-670-G	A	Figure 5	121	380-480V	1336S/F-B500 - B600	1336T-B500 - B600	1336E-B500 - B600	G	

Components Included with Filter

Item	Quantity - 1336-RFB- . . .			
	7-A, 16-A, 30-A	30-A4, 27-B, 48-B, 80-C	150-D, 180-D, 340-E	475-G, 590-G, 670-G
Filter	1	1	1	1
EMT Conduit	-	1	1	-
EMT Conduit Fitting	-	1	2	-
Bolts	-	4	8	3
Flat Washers	-	4	-	-
Star Washers	-	4	-	-
Terminal Block Housing	1	-	-	-
Standoffs	2	-	-	-
Nuts	3	4	-	3

Filter Dimensions

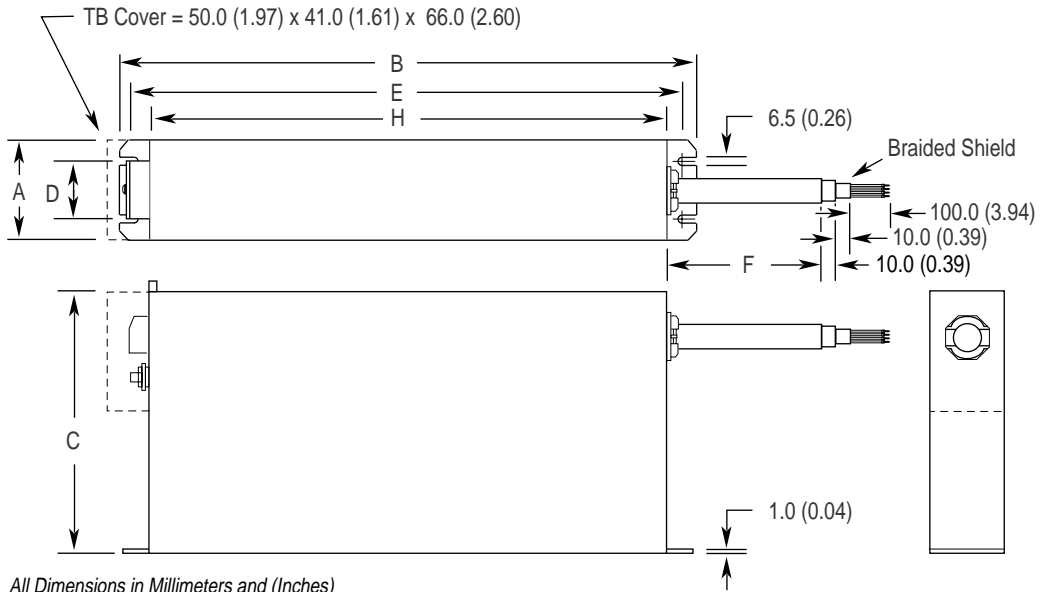

All Dimensions in Millimeters and (Inches)

Catalog Number	A	B	C	D	E	F	H	Weight kg (lbs.)
1336-RFB-7-AA	50.0 (1.97)	255.0 (10.04)	126.0 (4.96)	25.0 (0.98)	240.0 (9.45)	180.0 (7.09)	225.0 (8.86)	1.1 (2.4)
1336-RFB-16-AA	55.0 (2.17)	305.0 (12.00)	142.0 (5.59)	30.0 (1.18)	290.0 (11.42)	230.0 (9.06)	275.0 (10.83)	1.7 (3.8)
1336-RFB-30-A	60.0 (2.36)	335.0 (13.19)	160.0 (6.30)	35.0 (1.38)	320.0 (12.60)	280.0 (11.02)	305.0 (12.00)	1.8 (4.0)

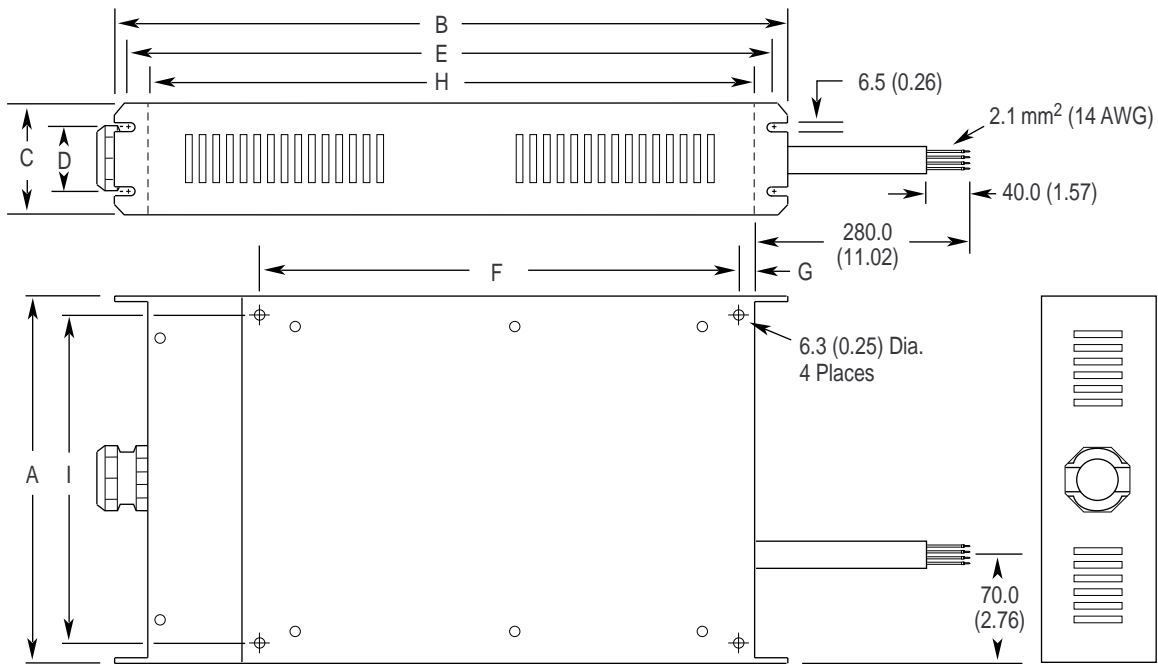

All Dimensions in Millimeters and (Inches)

Catalog Number	A	B	C	D	E	F	G	H	I
1336-RFB-7-A & 16-A Series B	215.9 (8.50)	390.0 (15.35)	58.0 (2.28)	30.0 (1.18)	375.0 (14.76)	275.0 (10.83)	7.5 (0.30)	360.0 (14.17)	185.2 (7.29)

Filter Dimensions *(continued)*

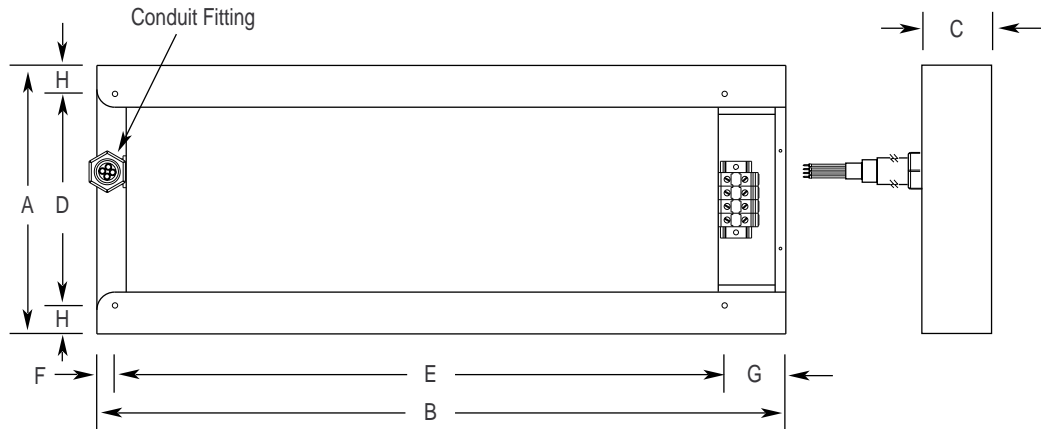

Catalog Number	A	B	C	D	E	F	G	H	Weight kg (lbs.)
1336-RFB-30-A4	260.1 (10.24)	413.7 (16.29)	58.0 (2.28)	230.1 (9.06)	320.0 (12.60)	15.0 (0.59)	70.0 (2.76)	15.0 (0.59)	4.9 (10.8)
1336-RFB-27-B	276.6 (10.89)	540.0 (21.26)	58.0 (2.28)	212.6 (8.37)	461.0 (18.15)	10.9 (0.43)	68.1 (2.68)	32.0 (1.26)	7.0 (15.4)
1336-RFB-48-B	276.6 (10.89)	540.0 (21.26)	68.1 (2.68)	212.6 (8.37)	461.0 (18.15)	10.9 (0.43)	68.1 (2.68)	32.0 (1.26)	8.5 (18.7)
1336-RFB-80-C	302.0 (11.89)	775.0 (30.50)	78.5 (3.09)	238.0 (9.37)	685.8 (27.00)	20.4 (0.80)	68.8 (2.70)	32.0 (1.26)	12.0 (26.5)

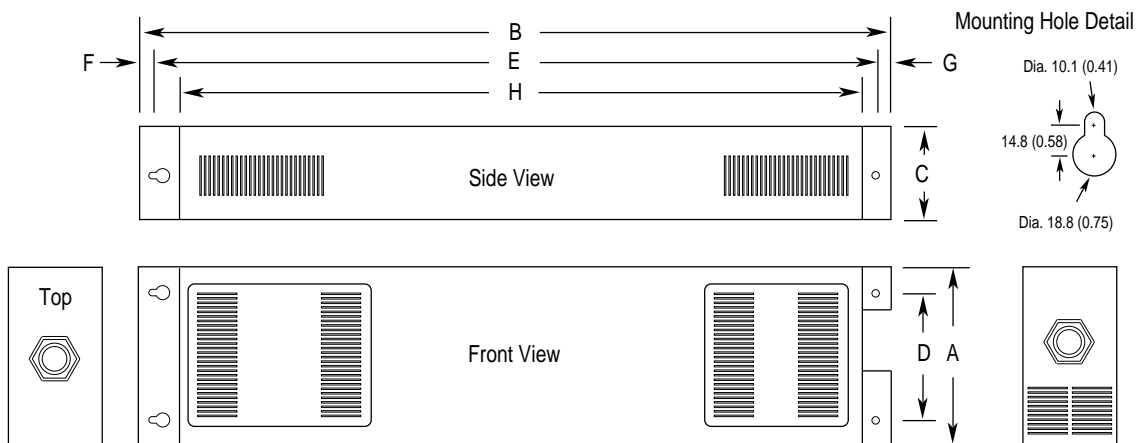

All Dimensions in Millimeters and (Inches)

Catalog Number	A	B	C	D	E	F	G	H	Weight kg (lbs.)
1336-RFB-150-D	270.0	1200.0	147.2	204.0	1159.4	20.3	20.3	1108.3	25.0
1336-RFB-180-D	(10.63)	(47.20)	(5.80)	(8.03)	(45.65)	(0.80)	(0.80)	(43.63)	(55.1)
1336-RFB-340-E	377.0	1392.0	155.0	308.0	1346.1	23.0	23.0	1265	37.0
	(14.84)	(54.80)	(6.10)	(12.13)	(53.00)	(0.91)	(0.91)	(49.80)	(81.6)



ATTENTION: To prevent electrical shock, disconnect the power source before installing or servicing.

1. Perform the appropriate step below (A, B, C, D or E) to mount the filter and drive.

A. 1336-RFB-7-AA, 16-AA, 30-A Filters

Mount the filter and drive to the panel. See the Dimension & Mounting diagrams provided in this document. Drive mounting information can be found in the User Manual.

B. 1336-RFB-7-A, 16-A Series B Filters

Two mounting methods are available; filter and drive (as one assembly) or side-by-side. Choose the method that best suits your application, then refer to the Dimension information on [page 6](#) and mounting diagram on [page 11](#). Drive mounting information can be found in the User Manual.

Important: Hardware must be installed as shown in the Mounting diagram on [page 11](#).

C. 1336-RFB-30-A4, 27-B, 48-B, 80-C Filters

Using the supplied hardware, mount the filter and drive (as one assembly) to the panel. Hardware must be installed as shown in [Figure 2 on page 11](#).

D. 1336-RFB-150-D, 180-D, 340-E Filters

a) Mount the drive to the panel using the Mounting diagram provided in this document as a guide. Drive mounting information can be found in the User Manual.

b) Using the Dimension and Mounting diagrams provided, correctly orient and temporarily mount the filter (using top mounting hole(s) only) to the enclosure back plane.

Important: Filter must be carefully positioned for proper alignment with the conduit box (and drive).

c) Insert lower filter bolt(s) and secure all hardware. Remove the lower filter access panel and conduit box cover.

d) Attach the conduit box to both the filter and drive using the two nipples/fittings and locknuts provided. Refer to the diagram on [page 14](#) for knockout definitions and mounting point for conduit box.

e) Route filter output leads through the conduit box and into the drive. Replace access panel and conduit box cover.

E. 1336-RFB-475-G, 590-G, 670-G Filters

Mount the filter using the Dimension & Mounting diagrams provided in this document. Drive mounting information can be found in the User Manual.

- The RFI filter must be connected between the incoming AC supply line and the drive input terminals.

Important: The filter may cause ground leakage currents. Therefore a solid ground connection must be provided as shown below.

Remove the filter access panel (or terminal block cover) to expose the input terminal block. Connect the incoming AC lines (see [note 1](#)) to the appropriate terminals on the block ("Line/L1, L2, L3"). Replace access panel/cover.

Incoming AC lines are connected to 1336-RFB-475, 590, 670 filters at the lower set of filter bus bars.

¹ Input power (source to filter) wiring must be in conduit or have shielding/armor with equivalent attenuation.



ATTENTION: To guard against possible equipment damage, RFI filters can only be used with AC supplies that are nominally balanced (and grounded) with respect to ground. In some installations, three-phase supplies are occasionally connected in a 3-wire configuration with one phase grounded (Grounded Delta). The filter must not be used in Grounded Delta supplies.

Filter Wiring - 1336 PLUS/PLUS II, FORCE & IMPACT

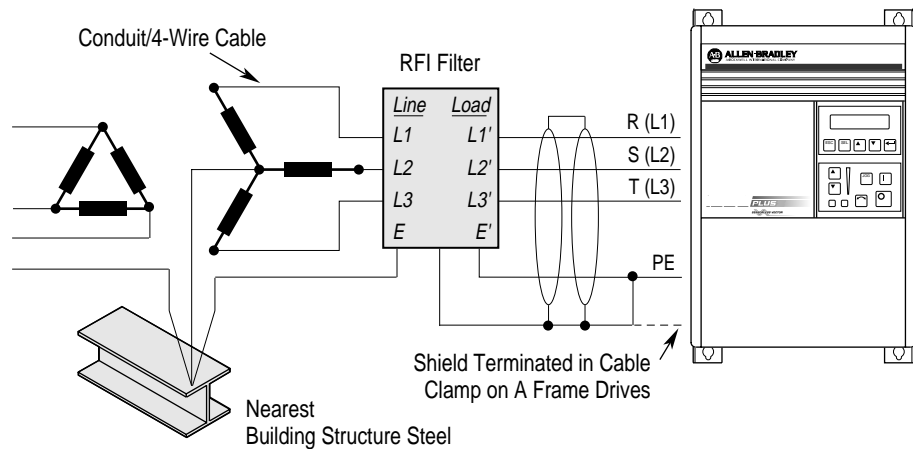

- Connect remaining wires. Cables must use knockouts as defined on [page 14](#).
- To assure that the RFI filter is effective and to reduce cable radiation, all cables entering and/or exiting the filter/drive must be shielded or armored. The ground conductor of the motor cable (drive end) must be connected directly to the drive ground terminal, not to the enclosure bus bar. At the motor end, the ground conductor should also be connected to the motor case ground. The shield or armor should be bonded to the filter (and drive). At the motor end, the shield should also be connected to the motor case ground.

Filter Mounting

Series B Filters can be mounted using either method

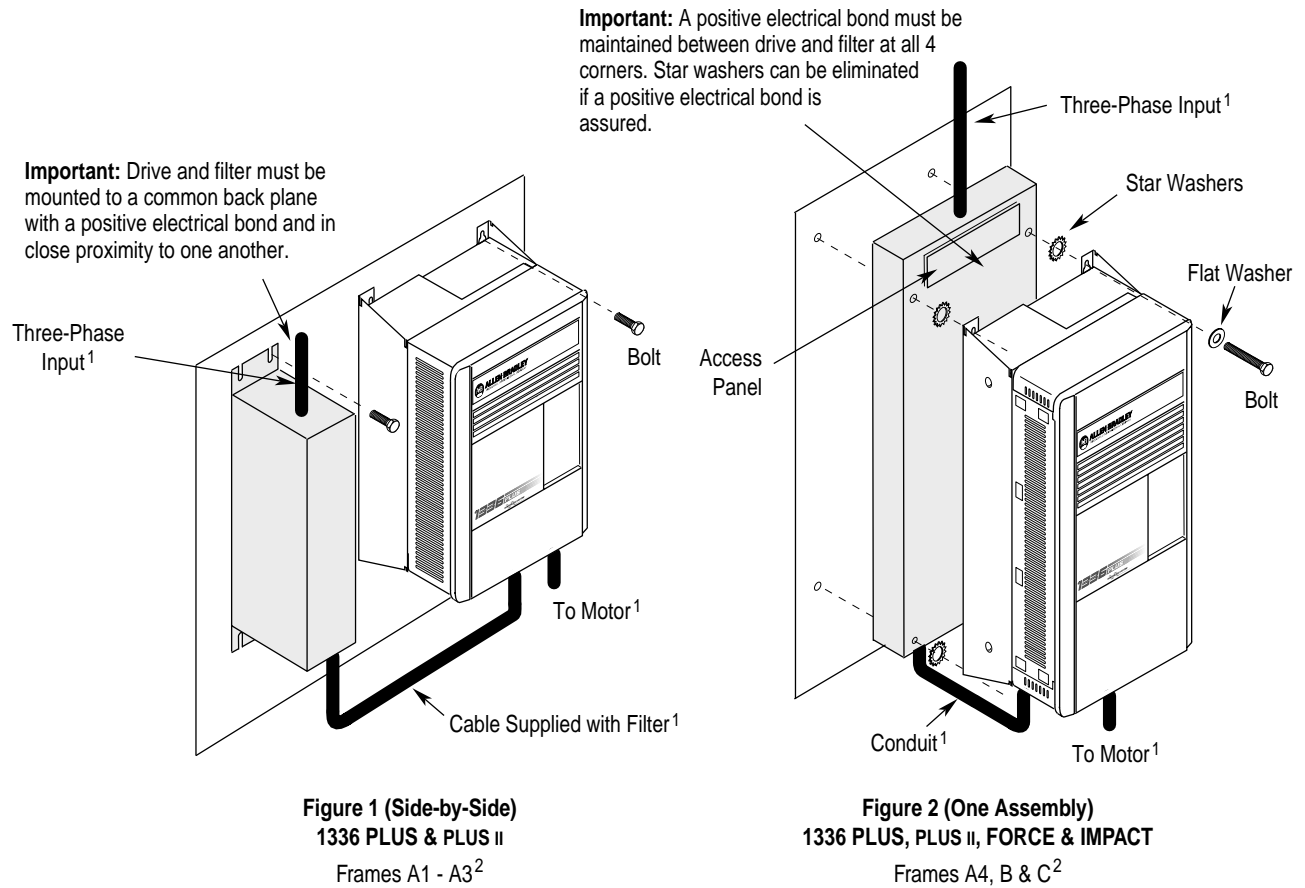

¹ Input power (source to filter) and output power (filter to drive and drive to motor) wiring must be in conduit or have shielding/armor with equivalent attenuation. Shielding/armor must be bonded to the metal bottom plate.

² Refer to the Filter Selection table on [page 5](#) for frame references and corresponding catalog numbers.

Filter Mounting *(continued)*

Important: Drive and filter must be mounted to a common back plane with a positive electrical bond. Spacing is determined by Conduit Box.

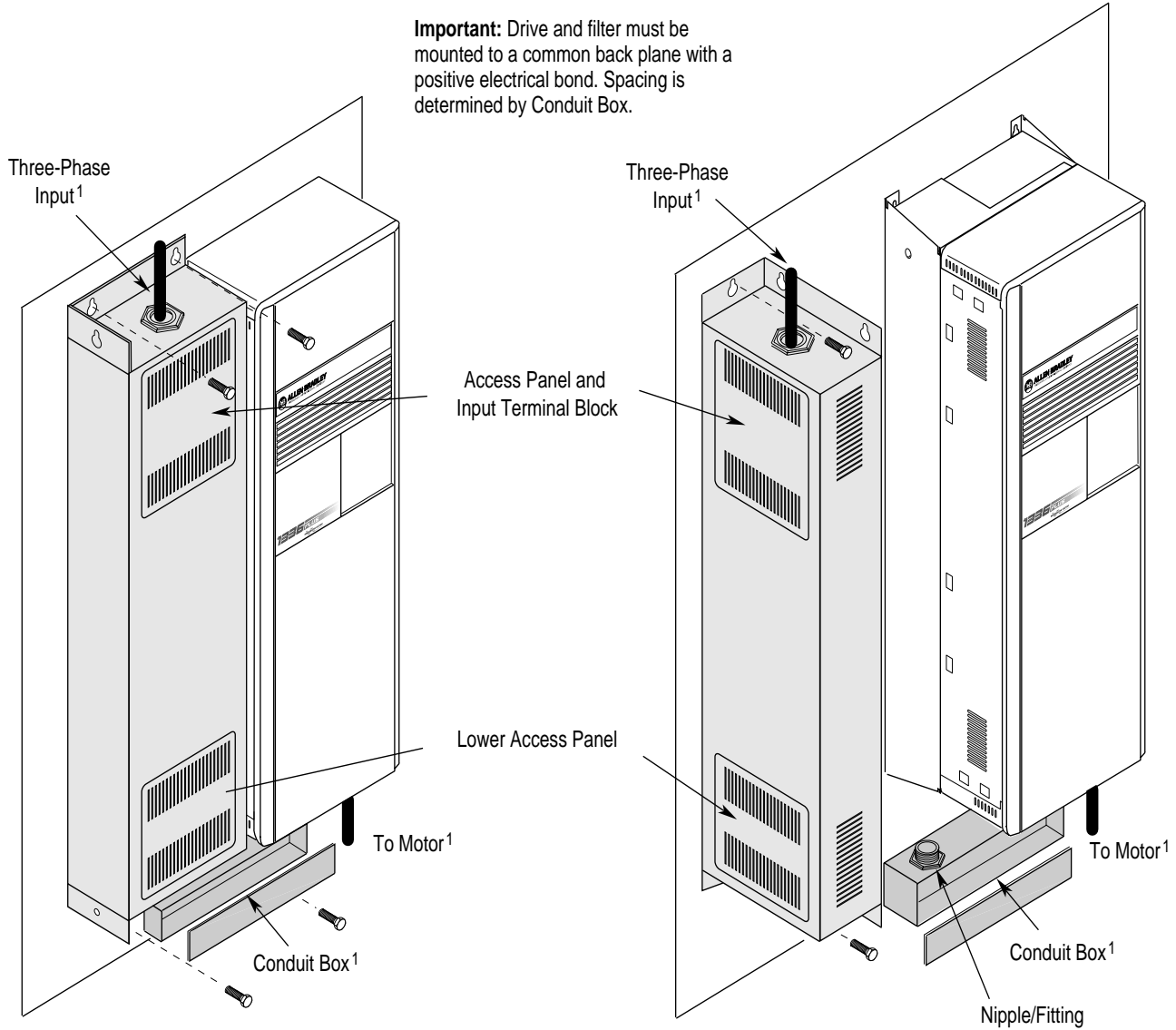

Figure 3
1336 PLUS, PLUS II, FORCE & IMPACT
(Through-the-Wall Mounting)
 Frames D & E ²

Figure 4
1336 PLUS, PLUS II, FORCE & IMPACT
(Conventional Mounting)
 Frames D & E ²

¹ Input power (source to filter) and output power (filter to drive and drive to motor) wiring must be in conduit or have shielding/armor with equivalent attenuation. Shielding/armor must be bonded to the metal bottom plate.
² Refer to the Filter Selection table on [page 5](#) for frame references and corresponding catalog numbers.

Filter Mounting *(continued)*

Important: A positive electrical bond must be maintained between the enclosure and filter (including brackets), fans, and drive. To assure a positive electrical bond, any paint near all mounting points must be removed.

Important: Cooling fans are required for proper drive operation. Fans and air intake openings must be EMI shielded. Refer to the drive User Manual for CFM recommendations.

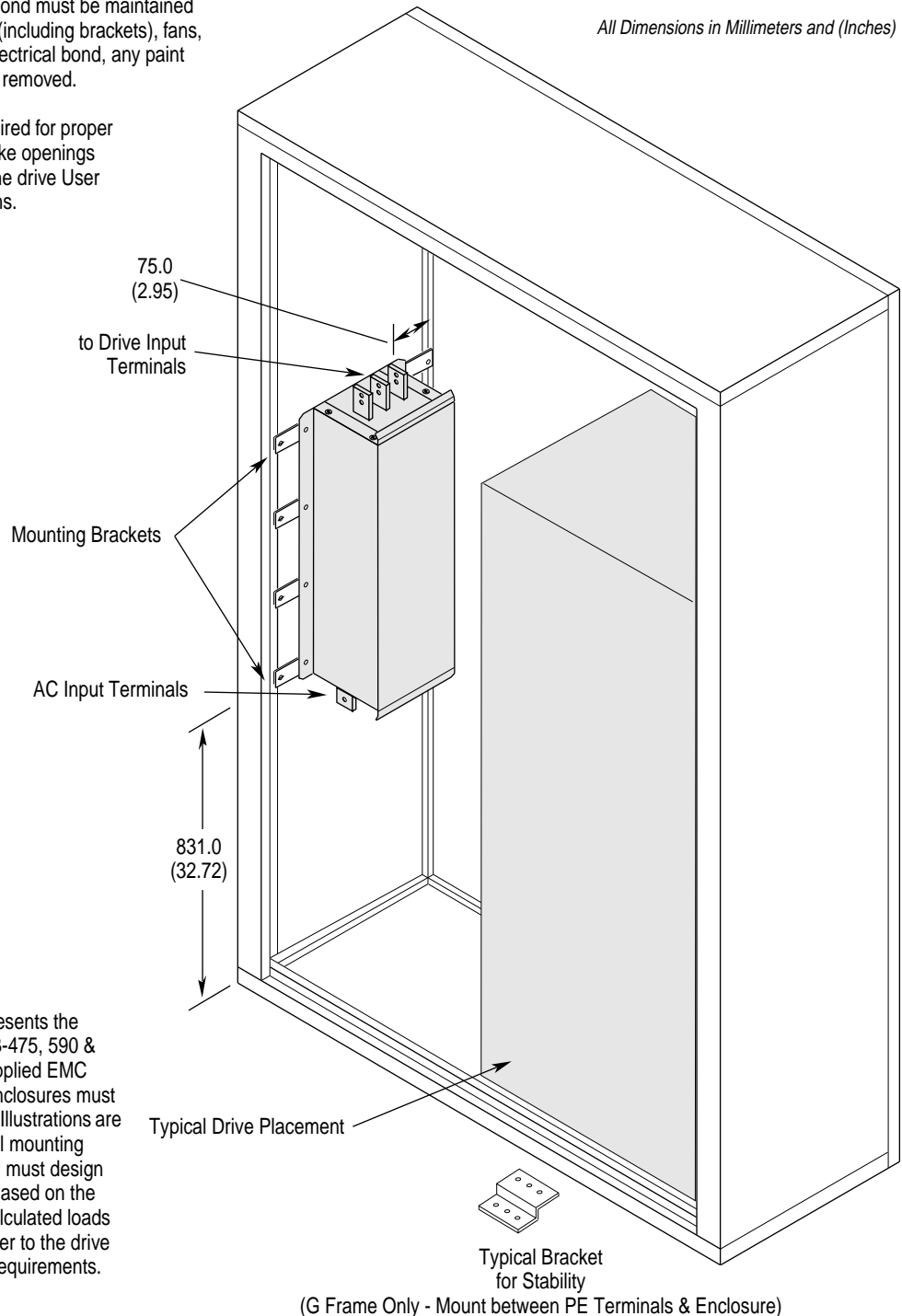

Important: This information represents the method used to mount 1336-RFB-475, 590 & 670 filters in an Allen-Bradley supplied EMC enclosure. User supplied EMC enclosures must follow all of the guidelines shown. Illustrations are only intended to identify structural mounting points and hardware shapes. You must design and fabricate steel components based on the actual mounting configuration, calculated loads and enclosure specifications. Refer to the drive User Manual for drive mounting requirements.

Figure 5
1336 PLUS, PLUS II, FORCE & IMPACT
(Typical Filter Mounting)

Frames F & G ^{1,2}

¹ Input power (source to filter) and output power (filter to drive and drive to motor) wiring must be in conduit or have shielding/armor with equivalent attenuation. Shielding/armor must be bonded to the metal bottom plate.

² Refer to the Filter Selection table on [page 5](#) for frame references and corresponding catalog numbers.

1336 PLUS, PLUS II, FORCE & IMPACT Knockout Definitions

Dimensions are in Millimeters and (Inches)

Frames A1 through A4

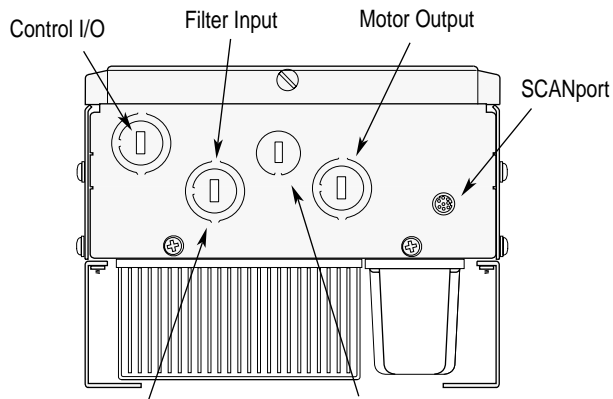

22.2/28.6 (0.88/1.13) - 3 Plcs. 22.2 (0.88) - 1 Plc.

Frames B and C

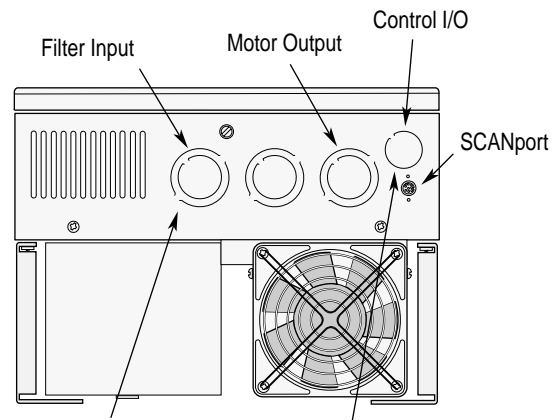

28.6/34.9 (1.13/1.38) - 3 Plcs. 22.2 (0.88) - 1 Plc.

Frame D

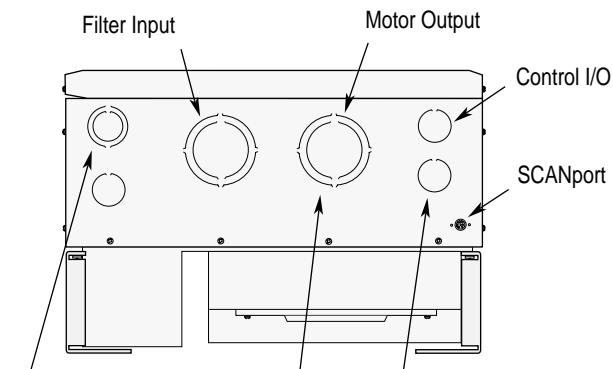

34.9/50.0 (1.38/1.97) - 1 Plc. 34.9 (1.38) - 3 Plcs.

62.7/76.2 (2.47/3.00) - 2 Plcs.

Frame E

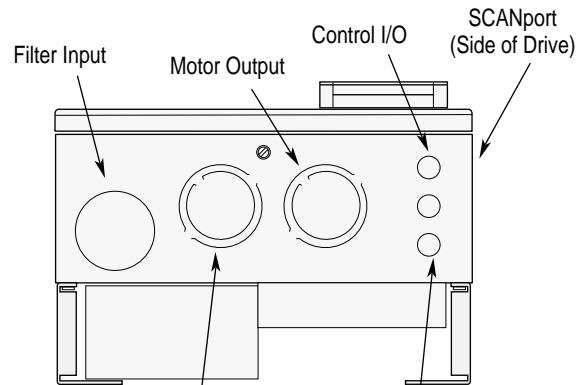

88.9/104.8 (3.50/4.13)
2 Plcs.

12.7 (0.50)
3 Plcs.

Notes:

1336 FORCE and 1336 IMPACT are trademarks of Rockwell Automation.

Reach us now at www.rockwellautomation.com

Wherever you need us, Rockwell Automation brings together leading brands in industrial automation including Allen-Bradley controls, Reliance Electric power transmission products, Dodge mechanical power transmission components, and Rockwell Software. Rockwell Automation's unique, flexible approach to helping customers achieve a competitive advantage is supported by thousands of authorized partners, distributors and system integrators around the world.

Americas Headquarters, 1201 South Second Street, Milwaukee, WI 53204, USA, Tel: (1) 414 382-2000, Fax: (1) 414 382-4444
European Headquarters SA/NV, avenue Herrmann Debroux, 46, 1160 Brussels, Belgium, Tel: (32) 2 663 06 00, Fax: (32) 2 663 06 40
Asia Pacific Headquarters, 27/F Citicorp Centre, 18 Whitfield Road, Causeway Bay, Hong Kong, Tel: (852) 2887 4788, Fax: (852) 2508 1846

