

## Eddy Current Displacement Transducer— Long Range Specifications

The PR 6426 is a non-contact eddy current transducer with a rugged construction and is designed for extremely critical turbomachinery applications such as steam, gas, compressor and hydro turbomachinery, blowers and fans.

The purpose of a displacement probe is to measure position or shaft movement without contacting the measured surface – the rotor. In the case of sleeve bearing machines, the shaft is separated from the bearing material by a thin film of oil. The oil acts as a dampener and therefore the vibration and position of the shaft are not transmitted through the bearing to the bearing case.

The use of case vibration sensors is discouraged for monitoring sleeve bearing machines since the vibration produced by shaft motion or position is greatly attenuated through the bearing oil film. The ideal method of monitoring shaft position and motion is by mounting a non-contact eddy sensor through the bearing, or inside the bearing, measuring the shaft motion and position directly.

The PR 6426 is commonly used to measure vibration of machine shafts, eccentricity, thrust (axial displacement), differential expansion, valve position, and air gaps.

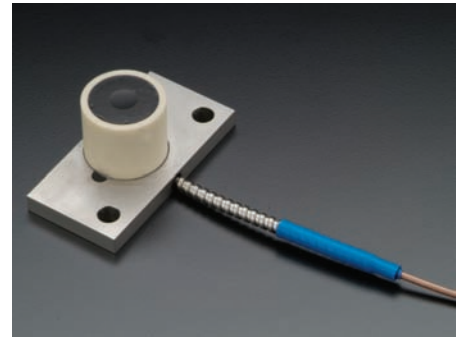

- Non-contact measurement of static and dynamic shaft displacement
  - Axial and radial shaft displacement (position, differential expansion)
- Meets international standards, DIN 45670, ISO 10817-1 and API 670
- Rated for explosive area, Eex ib IIC T6/T4
- Other displacement sensor selections include PR 6422, 6423, 6424 and 6425
- Select sensor driver such as CON 011/91, 021/91, 041/91, and cable for complete transducer system

Technical Data	
Measuring range	Static: $\pm 4.0$ mm (.16 in)
Sensitivity	2 V/mm
Target	Electrically conducting steel Cylindrical shaft <ul style="list-style-type: none"> <li>■ On measuring collars, if target surface is less than 60 mm (2.36 in) diameter, then error may be 1% or greater.</li> <li>■ Error negligible when target surface is greater than 60 mm (2.36 in) in diameter.</li> </ul> Peripheral speed of shaft: 0 to 2500 m/s Shaft diameter > 200 mm (7.87 in) Nominal gap (center of measuring range): 5.5 mm (.22 in)
Measuring error after calibration	< $\pm 1.5\%$ linearity error
Temperature error	Zero point: 200 mV / 100° K Sensitivity: < 2% / 100° K
Long term drift	0.3% max.
Influence of supply voltage	< 20 mV/V
Operating temperature range	-35 to +180° C (-31 to 356° F) (short term, up to 5 hours, up to +200° C / 392° F)
Temperature range for storage	-40 to +70° C (-40 to 158° F)
Mounting flange	80 x 40 x 8 mm (3.15 x 1.57 x .31 in)
Housing material	Stainless steel
Pressure resistance to sensor head	6,500 hPa
Pressure and differential pressure resistance at cable outlet	on request
Vibration and shock nominal values at 25° C (77° F)	4 g at 60 Hz
Cable length	PR 6426/000-100 PR 6426/010-100 3m continuous, no separate extension cable
Maximum cable temperature	+200° C (392° F)
Connection of transducer to converters	CON 011 and CON 021, Lemo plug CON 041, blunt cut cable for screw terminals
Cable protection	Severe and high performance insulation, PTFE, armored cable
Net weight without armored cable	0.8 kg (1.76 lbs)
Net weight with armored cable	1.0 kg (2.2 lbs)
Gross weight without armored cable	1.0 kg (2.2 lbs)
Gross weight with armored cable	1.2 kg (2.65 lbs)

# Dimensions:

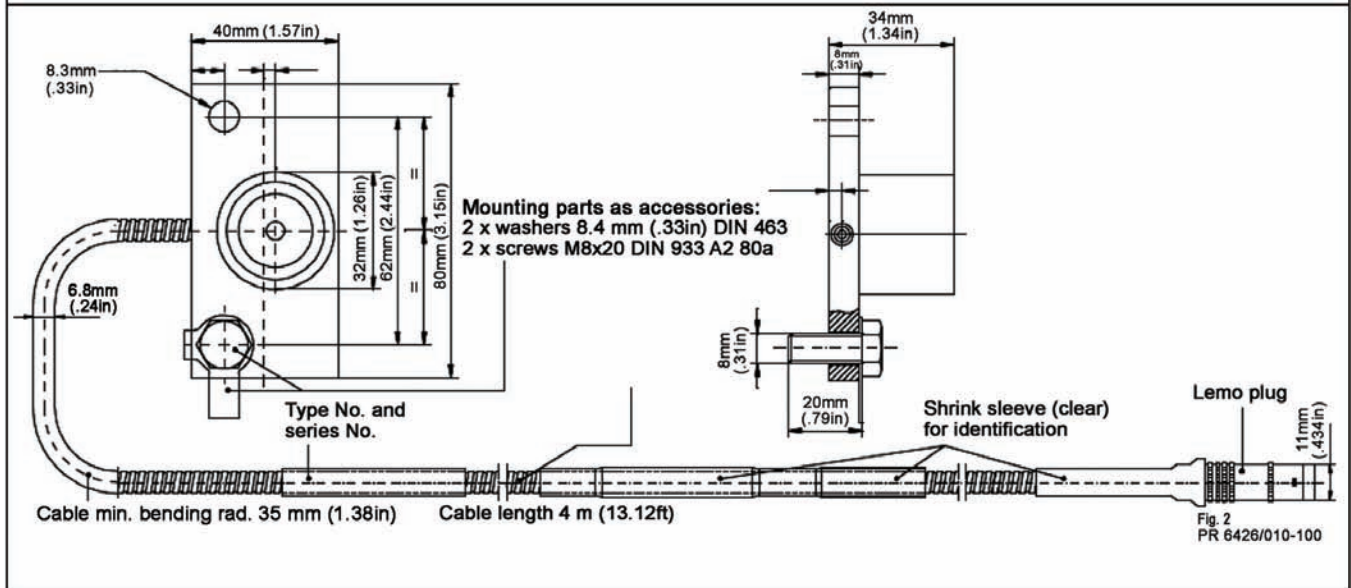
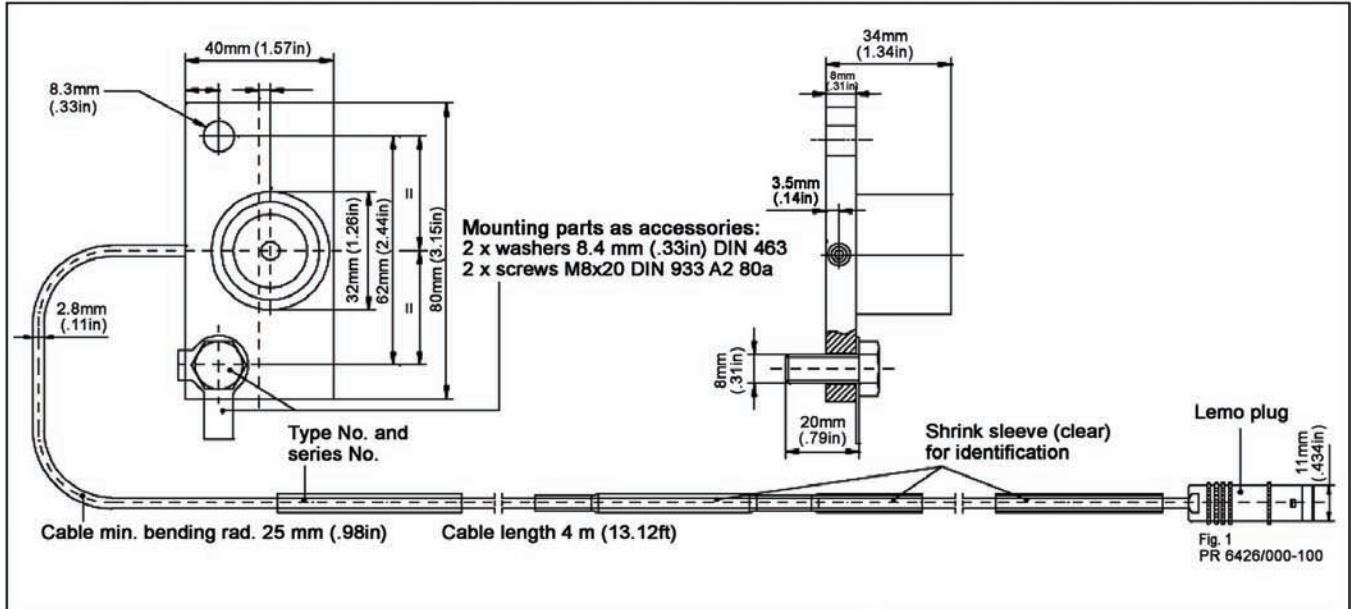

## Static Output Characteristics:

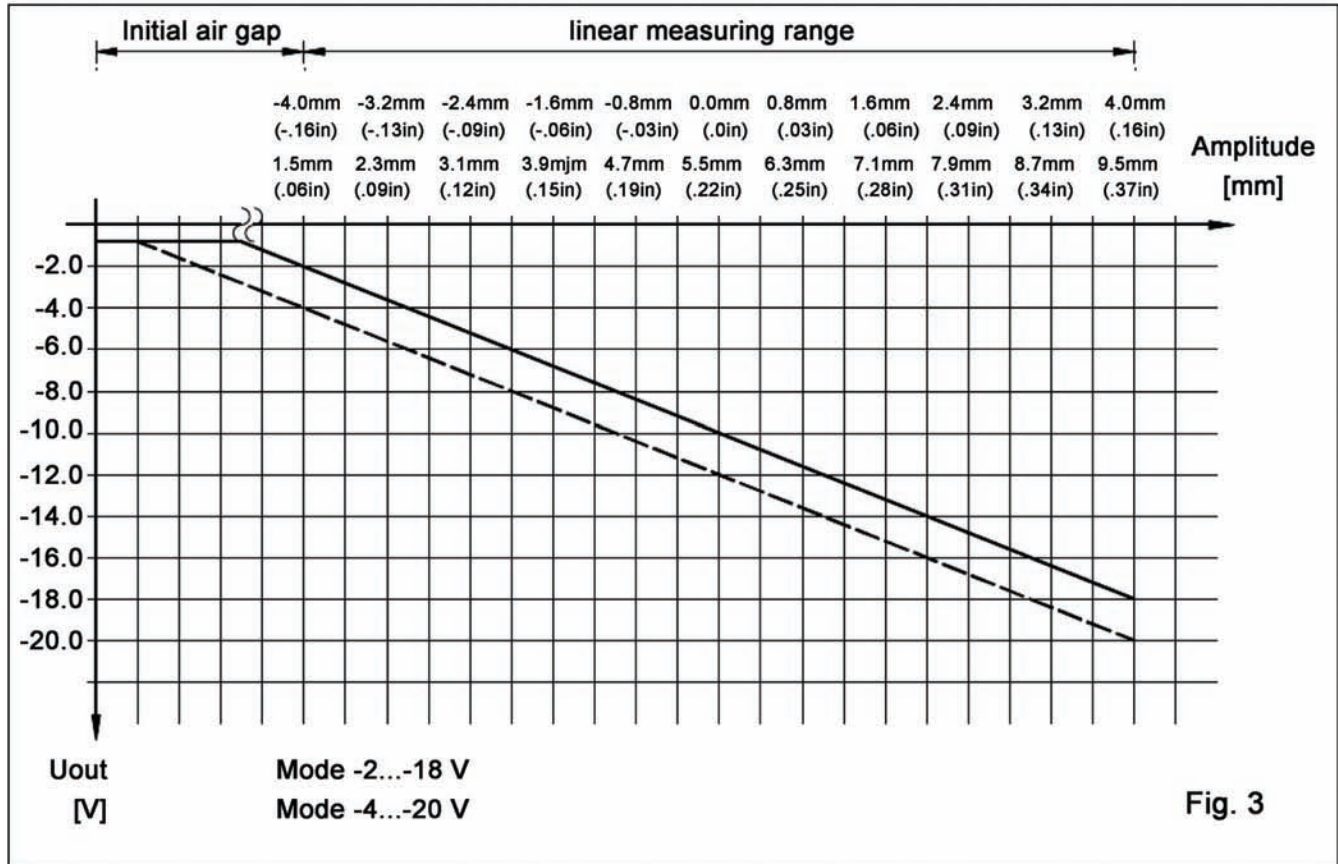

**Order Matrix, PR 6426**

	<b>PR 6426</b>	0	x	0	-	x	x	x
<b>Mounting Flange:</b> 80 x 40 x 8 mm (3.5 x 1.57 x .31 in)		0			-			
<b>Armored cable:</b> Without			0		-			
With			1					
<b>Sleeve length (+9.0 mm (.35 in) = total length):</b> 25 mm (.98in)				0				
<b>Adapter plug at 1 m (3.28 ft):</b> With						0		
Without						1		
<b>Total cable length:</b> 4 m (13.12 ft)							0	
5 m (16.4 ft)							1	
6 m (19.69 ft)							2	
8 m (26.25 ft)							3	
10 m (32.81 ft)							4	
<b>Cable end:</b> Lemo connector for driver								0
Blunt cut cable end for driver								1
	<b>PR 6426</b>	0		0	-			

**Optional Accessories**

Mounting brackets, armored cable, cable exist seals and safety barriers for hazardous or intrinsically-safe areas

**Emerson Process Management  
Asset Optimization Division**

835 Innovation Drive  
Knoxville, TN 37932 USA  
T (865) 675-2400  
F (865) 218-1401

©2010, Emerson Process Management.

The contents of this publication are presented for informational purposes only, and while every effort has been made to ensure their accuracy, they are not to be construed as warranties or guarantees, express or implied, regarding the products or services described herein or their use or applicability. All sales are governed by our terms and conditions, which are available on request. We reserve the right to modify or improve the designs or specifications of our products at any time without notice.

All rights reserved. Machinery Health, is a mark of one of the Emerson Process Management group of companies. The Emerson logo is a trademark and service mark of Emerson Electric Co. All other marks are the property of their respective owners.

