

1756 ControlLogix I/O Specifications

Catalog Numbers 1756 series

Topic	Page
Available 1756 I/O Modules	2
ControlLogix I/O Accessories	190

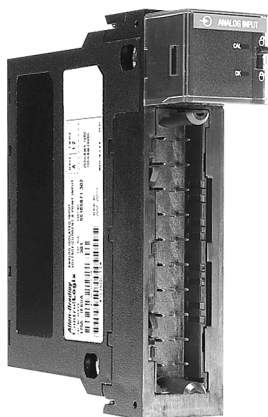

The ControlLogix architecture provides a wide range of input and output modules to span many applications, from high-speed digital to process control. The ControlLogix architecture uses Producer-Consumer technology, which allows input information and output status to be shared among multiple ControlLogix controllers.

Each ControlLogix I/O module mounts in a ControlLogix chassis and **requires** either a removable terminal block (RTB) or a 1492 interface module (IFM) to connect all field-side wiring. RTBs and IFMs are not included with the I/O modules. They must be ordered separately.

Available 1756 I/O Modules

You can select these types of digital I/O modules.

Digital I/O Type	Description
Diagnostic	These modules provide diagnostic features to the point level. These modules have a D at the end of the catalog number.
Electronic fusing	These modules have internal electronic fusing to prevent too much current from flowing through the module. These modules have an E at the end of the catalog number.
Individually isolated	These modules have individually isolated inputs or outputs. These modules have an I at the end of the catalog number.

I/O Type	Cat. No.	Page	Cat. No.	Page
AC digital	1756-IA8D	3	1756-OA8	97
	1756-IA16	6	1756-OA8D	100
	1756-IA16I	9	1756-OA8E	103
	1756-IA32	12	1756-OA16	106
	1756-IM16I	72	1756-OA16I	109
	1756-IN16	75	1756-ON8	161
DC digital	1756-IB16	15	1756-OB8	112
	1756-IB16D	18	1756-OB8EI	115
	1756-IB16I	21	1756-OB8I	118
	1756-IB16ISOE	24	1756-OB16D	121
	1756-IB32	27	1756-OB16E	124
	1756-IC16	30	1756-OB16I	127
	1756-IG16	63	1756-OB16IS	130
	1756-IH16I	66	1756-OB32	133
	1756-IH16ISOE	69	1756-OC8	136
	1756-IV16	91	1756-OG16	155
	1756-IV32	94	1756-OH8I	158
			1756-OV16E	164
			1756-OV32E	167
	Contact			1756-OW16I
			1756-OX8I	173
Analog	1756-IF6CIS	33	1756-OF4	139
	1756-IF6I	38	1756-OF6CI	142
	1756-IF8	43	1756-OF6VI	145
	1756-IF16	51	1756-OF8	148
	1756-IF4FXOF2F	59		
	1756-IR6I	78		
	1756-IT6I	83		
1756-IT6I2	87			
HART interface	1756-IF8H	48	1756-OF8H	152
	1756-IF16H	56		
Specialty	1756-CFM	176	1756-PLS	185
	1756-HSC	181		

1756-IA8D

ControlLogix AC (79...132V) diagnostic input module

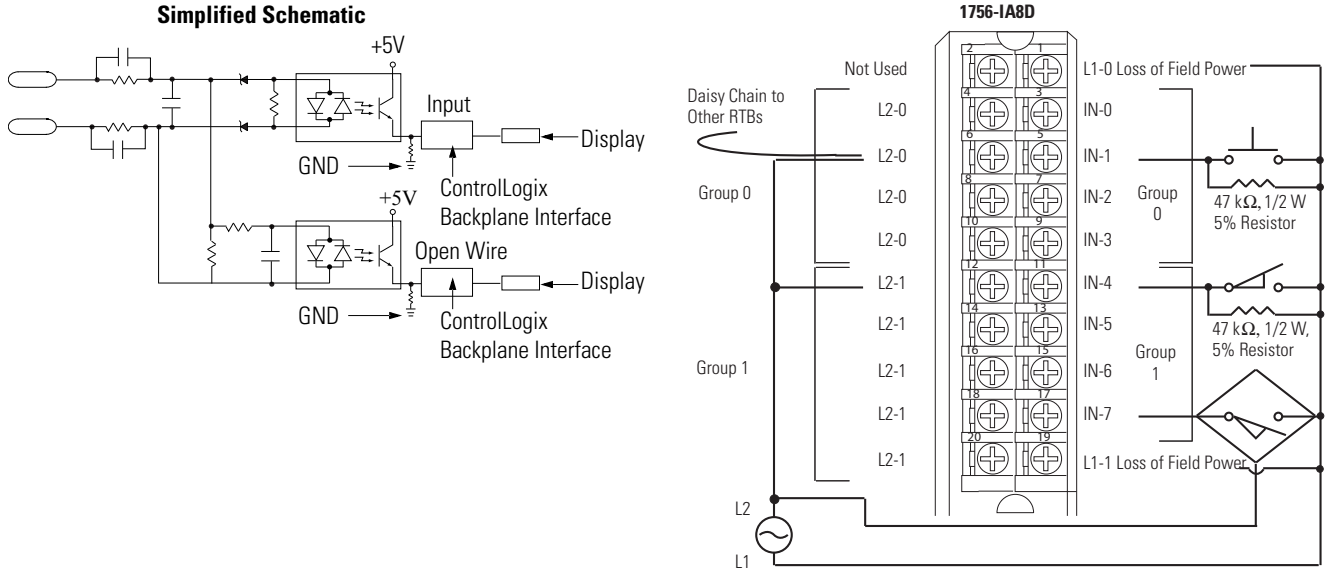

Diagnostic Specifications - 1756-IA8D

Attribute	1756-IA8D
Open wire	Off-state leakage current 1.5 mA min
Loss of power	Transition range 46...85V AC
Timestamp of diagnostics	±1 ms

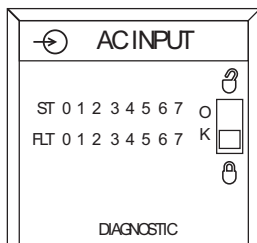

Technical Specifications - 1756-IA8D

Attribute	1756-IA8D
Inputs	8 diagnostic (4 points/group)
Voltage category	120V AC
Operating voltage range	79...132V AC, 47...63 Hz
Input voltage, nom	120V AC
Input delay time OFF to ON	Hardware delay: 10 ms max + filter time User-selectable filter time: 1 or 2 ms
ON to OFF	Hardware delay: 8 ms max + filter time User-selectable filter time: 9 or 18 ms
Current draw @ 5.1V	100 mA
Current draw @ 24V	3 mA
Total backplane power	0.58 W
Power dissipation, max	4.5 W @ 60 °C (140 °F)
Thermal dissipation	15.35 BTU/hr
Off-state voltage, max	20V

Technical Specifications - 1756-IA8D

Attribute	1756-IA8D
Off-state current, max	2.5 mA
On-state current, min	5 mA @ 74V AC
On-state current, max	16 mA @ 132V AC
Inrush current, max	250 mA
Input impedance, max	8.25 k Ω @ 132V AC, 60 Hz
Cyclic update time	200 μ s...750 ms
Change of state	Software configurable
Timestamp of inputs	\pm 200 μ s
Isolation voltage	125V (continuous), basic insulation type, inputs-to-backplane, and input group-to-group No isolation between individual group inputs Routine tested @ 1200V AC for 2 s
Module keying	Electronic, software configurable
Removable terminal block housing	1756-TBNH 1756-TBSH
RTB keying	User-defined mechanical
Slot width	1
Wire category	1 ⁽¹⁾
North American temperature code	T4A
Enclosure type	None (open-style)

(1) Use this conductor category information for planning conductor routing as described in the system-level installation manual. See the Industrial Automation Wiring and Grounding Guidelines, publication [1770-4.1](#).

Environmental Specifications - 1756-IA8D

Attribute	1756-IA8D
Temperature, operating IEC 60068-2-1 (Test Ad, Operating Cold), IEC 60068-2-2 (Test Bd, Operating Dry Heat), IEC 60068-2-14 (Test Nb, Operating Thermal Shock)	0...60 °C (32...140 °F)
Temperature, surrounding air, max	60 °C (140 °F)
Temperature, storage IEC 60068-2-1 (Test Ab, Unpackaged Nonoperating Cold), IEC 60068-2-2 (Test Bb, Unpackaged Nonoperating Dry Heat), IEC 60068-2-14 (Test Na, Unpackaged Nonoperating Thermal Shock)	-40...85 °C (-40...185 °F)
Relative humidity IEC 60068-2-30 (Test Db, Unpackaged Nonoperating Damp Heat)	5...95% noncondensing
Vibration IEC 60068-2-6 (Test Fc, Operating)	2 g @ 10...500 Hz
Shock, operating IEC 60068-2-27 (Test Ea, Unpackaged Shock)	30 g
Shock, nonoperating IEC 60068-2-27 (Test Ea, Unpackaged Shock)	50 g
Emissions	CISPR 11: Group 1, Class A
ESD immunity IEC 61000-4-2	6 kV contact discharges 8 kV air discharges

Environmental Specifications - 1756-IA8D

Attribute	1756-IA8D
Radiated RF immunity IEC 61000-4-3	10V/m with 1 kHz sine-wave 80% AM from 80... 2000 MHz 10V/m with 200 Hz 50% Pulse 100% AM @ 900 MHz 10V/m with 200 Hz 50% Pulse 100% AM @ 1890 MHz 3V/m with 1 kHz sine-wave 80% AM from 2000...2700 MHz
EFT/B immunity IEC 61000-4-4	±4 kV at 5 kHz on signal ports
Surge transient immunity IEC 61000-4-5	±1 kV line-line (DM) and ±2 kV line-earth (CM) on signal ports
Conducted RF immunity IEC 61000-4-6	10V rms with 1 Hz sine-wave 80% AM from 150 kHz...80 MHz

Certifications - 1756-IA8D

Certification ⁽¹⁾	1756-IA8D
UL	UL Listed Industrial Control Equipment, certified for US and Canada. See UL File E65584.
CSA	CSA Certified Process Control Equipment. See CSA File LR54689C. CSA Certified Process Control Equipment for Class I, Division 2 Group A,B,C,D Hazardous Locations. See CSA File LR69960C.
CE	European Union 2004/108/IEC EMC Directive, compliant with: <ul style="list-style-type: none"> • EN 61326-1; Meas./Control/Lab., Industrial Requirements • EN 61000-6-2; Industrial Immunity • EN 61000-6-4; Industrial Emissions • EN 61131-2; Programmable Controllers (Clause 8, Zone A & B) European Union 2006/95/EC LVD, compliant with: <ul style="list-style-type: none"> • EN 61131-2; Programmable Controllers)
C-Tick	Australian Radiocommunications Act, compliant with: AS/NZS CISPR 11; Industrial Emissions
FM	FM Approved Equipment for use in Class I Division 2 Group A,B,C,D Hazardous Locations
TÜV	TÜV Certified for Functional Safety ⁽²⁾ : Capable of SIL 2

(1) When marked. See the Product Certification link at <http://www.ab.com> for Declarations of Conformity, Certificates, and other certification details.

(2) When used with specified firmware revisions and in accordance with application guidelines described in Using ControlLogix in SIL2 Applications Safety Reference Manual, publication [1756-RM001](#).

1756-IA16

ControlLogix AC (79...132V) input module

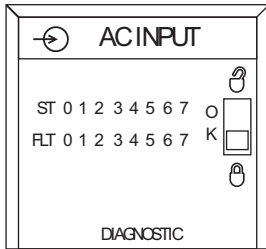
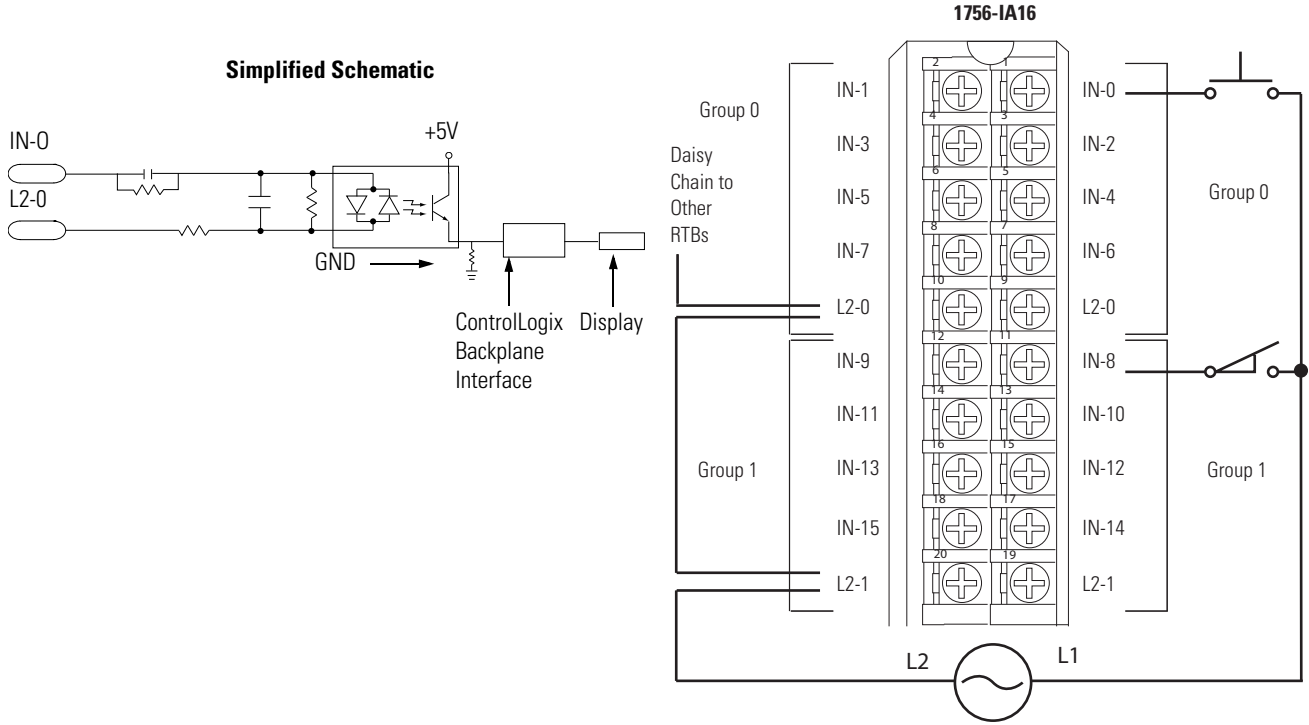

Technical Specifications - 1756-IA16

Attribute	1756-IA16
Inputs	16 (8 points/group)
Voltage category	120V AC
Operating voltage range	74...132V AC, 47...63 Hz
Input voltage, nom	120V AC
Input delay time OFF to ON	Hardware delay: 10 ms max + filter time User-selectable filter time: 1 or 2 ms
ON to OFF	Hardware delay: 8 ms max + filter time User-selectable filter time: 9 or 18 ms
Current draw @ 5.1V	100 mA
Current draw @ 24V	2 mA
Total backplane power	0.58 W
Power dissipation, max	5.8 W @ 60 °C (140 °F)
Thermal dissipation	18.41 BTU/hr
Off-state voltage, max	20V
Off-state current, max	2.5 mA
On-state current, min	5 mA @ 74V AC
On-state current, max	13 mA @ 132V AC

Technical Specifications - 1756-IA16

Attribute	1756-IA16
Inrush current, max	250 mA peak (decaying to <37% in 22 ms, without activation)
Input impedance, max	10.15 k Ω @ 132V AC, 60 Hz
Cyclic update time	200 μ s...750 ms
Change of state	Software configurable
Timestamp of inputs	\pm 200 μ s
Isolation voltage	125V (continuous), basic insulation type, inputs-to-backplane, and input group-to-group No isolation between individual group inputs Routine tested @ 1200V AC for 2 s
Module keying	Electronic, software configurable
Removable terminal block housing	1756-TBNH 1756-TBSH
RTB keying	User-defined mechanical
Slot width	1
Wire category	1 ⁽¹⁾
North American temperature code	T4
Enclosure type	None (open-style)

(1) Use this conductor category information for planning conductor routing as described in the system-level installation manual. See the Industrial Automation Wiring and Grounding Guidelines, publication [1770-4.1](#).

Environmental Specifications - 1756-IA16

Attribute	1756-IA16
Temperature, operating IEC 60068-2-1 (Test Ad, Operating Cold), IEC 60068-2-2 (Test Bd, Operating Dry Heat), IEC 60068-2-14 (Test Nb, Operating Thermal Shock)	0...60 °C (32...140 °F)
Temperature, surrounding air, max	60 °C (140 °F)
Temperature, storage IEC 60068-2-1 (Test Ab, Unpackaged Nonoperating Cold), IEC 60068-2-2 (Test Bb, Unpackaged Nonoperating Dry Heat), IEC 60068-2-14 (Test Na, Unpackaged Nonoperating Thermal Shock)	-40...85 °C (-40...185 °F)
Relative humidity IEC 60068-2-30 (Test Db, Unpackaged Nonoperating Damp Heat)	5...95% noncondensing
Vibration IEC 60068-2-6 (Test Fc, Operating)	2 g @ 10...500 Hz
Shock, operating IEC 60068-2-27 (Test Ea, Unpackaged Shock)	30 g
Shock, nonoperating IEC 60068-2-27 (Test Ea, Unpackaged Shock)	50 g
Emissions	CISPR 11: Group 1, Class A
ESD immunity IEC 61000-4-2	6 kV contact discharges 8 kV air discharges
Radiated RF immunity IEC 61000-4-3	10V/m with 1 kHz sine-wave 80% AM from 80...2000 MHz 10V/m with 200 Hz 50% Pulse 100% AM @ 900 MHz 10V/m with 200 Hz 50% Pulse 100% AM @ 1890 MHz 3V/m with 1 kHz sine-wave 80% AM from 2000...2700 MHz
EFT/B immunity IEC 61000-4-4	\pm 4 kV at 5 kHz on signal ports

Environmental Specifications - 1756-IA16

Attribute	1756-IA16
Surge transient immunity IEC 61000-4-5	±1 kV line-line (DM) and ±2 kV line-earth (CM) on signal ports
Conducted RF immunity IEC 61000-4-6	10V rms with 1 kHz sine-wave 80% AM from 150 kHz...80 MHz
Oscillatory surge withstand IEEE C37.90.1	3 kV

Certifications - 1756-IA16

Certification⁽¹⁾	1756-IA16
UL	UL Listed Industrial Control Equipment, certified for US and Canada. See UL File E65584.
CSA	CSA Certified Process Control Equipment. See CSA File LR54689C. CSA Certified Process Control Equipment for Class I, Division 2 Group A,B,C,D Hazardous Locations. See CSA File LR69960C.
CE	European Union 2004/108/IEC EMC Directive, compliant with: <ul style="list-style-type: none"> • EN 61326-1; Meas./Control/Lab., Industrial Requirements • EN 61000-6-2; Industrial Immunity • EN 61000-6-4; Industrial Emissions • EN 61131-2; Programmable Controllers (Clause 8, Zone A & B) European Union 2006/95/EC LVD, compliant with: <ul style="list-style-type: none"> • EN 61131-2; Programmable Controllers
C-Tick	Australian Radiocommunications Act, compliant with: AS/NZS CISPR 11; Industrial Emissions
FM	FM Approved Equipment for use in Class I Division 2 Group A,B,C,D Hazardous Locations

(1) When marked. See the Product Certification link at <http://www.ab.com> for Declarations of Conformity, Certificates, and other certification details.

1756-IA16I

ControlLogix AC (79...132V) isolated input module

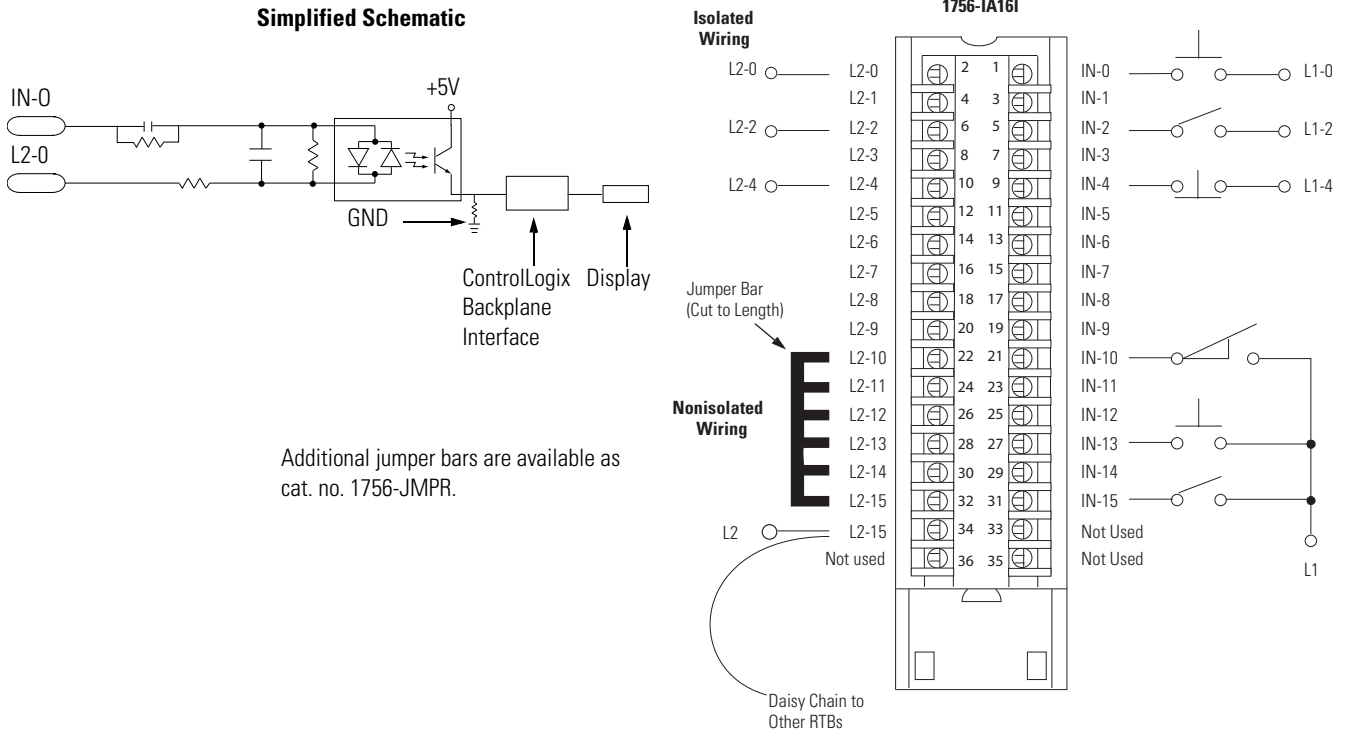

Additional jumper bars are available as cat. no. 1756-JMPR.

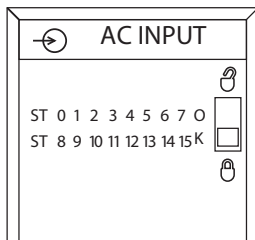

Technical Specifications - 1756-IA16I

Attribute	1756-IA16I
Inputs	16 individually isolated
Voltage category	120V AC
Operating voltage range	79...132V AC, 47...63 Hz
Input voltage, nom	120V AC
Input delay time OFF to ON	Hardware delay: 10 ms max + filter time User-selectable filter time: 1 or 2 ms
ON to OFF	Hardware delay: 8 ms max + filter time User-selectable filter time: 9 or 18 ms
Current draw @ 5.1V	125 mA
Current draw @ 24V	3 mA
Total backplane power	0.71 W
Power dissipation, max	4.9 W @ 60 °C (140 °F)
Thermal dissipation	16.71 BTU/hr
Off-state voltage, max	20V
Off-state current, max	2.5 mA
On-state current, min	5 mA @ 79V AC, 47...63 Hz
On-state current, max	15 mA @ 132V AC, 47...63 Hz

Technical Specifications - 1756-IA16I

Attribute	1756-IA16I
Inrush current, max	250 mA
Input impedance, max	8.8 k Ω @ 132V AC, 60Hz
Cyclic update time	200 μ s...750 ms
Change of state	Software configurable
Timestamp of inputs	\pm 200 μ s
Isolation voltage	125V (continuous), basic insulation type, inputs-to-backplane, and input-to-input Routine tested @ 1200V AC for 2 s
Module keying	Electronic, software configurable
Removable terminal block housing	1756-TBCH 1756-TBS6H
RTB keying	User-defined mechanical
Slot width	1
Wire category	1 ⁽¹⁾
North American temperature code	T4A
Enclosure type	None (open-style)

(1) Use this conductor category information for planning conductor routing as described in the system-level installation manual. See the Industrial Automation Wiring and Grounding Guidelines, publication [1770-4.1](#).

Environmental Specifications - 1756-IA16I

Attribute	1756-IA16I
Temperature, operating IEC 60068-2-1 (Test Ad, Operating Cold), IEC 60068-2-2 (Test Bd, Operating Dry Heat), IEC 60068-2-14 (Test Nb, Operating Thermal Shock)	0...60 °C (32...140 °F)
Temperature, surrounding air, max	60 °C (140 °F)
Temperature, storage IEC 60068-2-1 (Test Ab, Unpackaged Nonoperating Cold), IEC 60068-2-2 (Test Bb, Unpackaged Nonoperating Dry Heat), IEC 60068-2-14 (Test Na, Unpackaged Nonoperating Thermal Shock)	-40...85 °C (-40...185 °F)
Relative humidity IEC 60068-2-30 (Test Db, Unpackaged Nonoperating Damp Heat)	5...95% noncondensing
Vibration IEC 60068-2-6 (Test Fc, Operating)	2 g @ 10...500 Hz
Shock, operating IEC 60068-2-27 (Test Ea, Unpackaged Shock)	30 g
Shock, nonoperating IEC 60068-2-27 (Test Ea, Unpackaged Shock)	50 g
Emissions	CISPR 11: Group 1, Class A
ESD immunity IEC 61000-4-2	6 kV contact discharges 8 kV air discharges
Radiated RF immunity IEC 61000-4-3	10V/m with 1 kHz sine-wave 80% AM from 80...2000 MHz 10V/m with 200 Hz 50% Pulse 100% AM @ 900 MHz 10V/m with 200 Hz 50% Pulse 100% AM @ 1890 MHz 3V/m with 1 kHz sine-wave 80% AM from 2000...2700 MHz
EFT/B immunity IEC 61000-4-4	\pm 4 kV at 5 kHz on signal ports

Environmental Specifications - 1756-IA16I

Attribute	1756-IA16I
Surge transient immunity IEC 61000-4-5	±1 kV line-line (DM) and ±2 kV line-earth (CM) on signal ports
Conducted RF immunity IEC 61000-4-6	10V rms with 1 kHz sine-wave 80% AM from 150 kHz...80 MHz
Oscillatory surge withstand IEEE C37.90.1	3 kV

Certifications - 1756-IA16I

Certification ⁽¹⁾	1756-IA16I
UL	UL Listed Industrial Control Equipment, certified for US and Canada. See UL File E65584.
CSA	CSA Certified Process Control Equipment. See CSA File LR54689C. CSA Certified Process Control Equipment for Class I, Division 2 Group A,B,C,D Hazardous Locations. See CSA File LR69960C.
CE	European Union 2004/108/IEC EMC Directive, compliant with: <ul style="list-style-type: none"> • EN 61326-1; Meas./Control/Lab., Industrial Requirements • EN 61000-6-2; Industrial Immunity • EN 61000-6-4; Industrial Emissions • EN 61131-2; Programmable Controllers (Clause 8, Zone A & B) European Union 2006/95/EC LVD, compliant with: <ul style="list-style-type: none"> • EN 61131-2; Programmable Controllers
C-Tick	Australian Radiocommunications Act, compliant with: AS/NZS CISPR 11; Industrial Emissions
FM	FM Approved Equipment for use in Class I Division 2 Group A,B,C,D Hazardous Locations
TÜV	TÜV Certified for Functional Safety ⁽²⁾ : Capable of SIL 2

(1) When marked. See the Product Certification link at <http://www.ab.com> for Declarations of Conformity, Certificates, and other certification details.

(2) When used with specified firmware revisions and in accordance with application guidelines described in Using ControlLogix in SIL2 Applications Safety Reference Manual, publication [1756-RM001](#).

1756-IA32

ControlLogix AC (74...132V) input module

Simplified Schematic

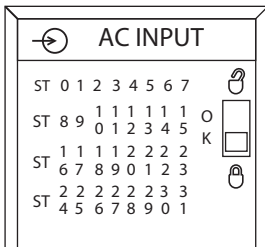
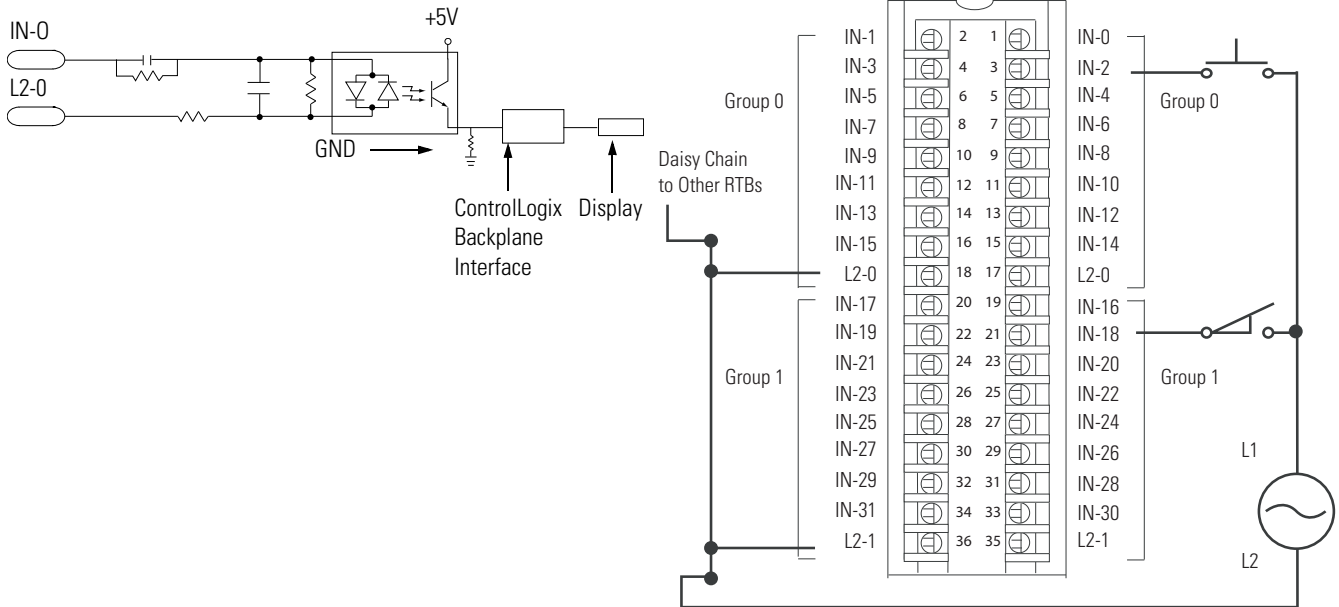

Technical Specifications - 1756-IA32

Attribute	1756-IA32
Inputs	32 diagnostic (4 points/group)
Voltage category	120V AC
Operating voltage range	74...132V AC, 47...63 Hz
Input voltage, nom	120V AC
Input delay time OFF to ON	Hardware delay: 1.5 ms nom/10 ms max + filter time User-selectable filter time: 1 or 2 ms
ON to OFF	Hardware delay: 1 ms nom/8 ms max + filter time User-selectable filter time: 9 or 18 ms
Current draw @ 5.1V	165 mA
Current draw @ 24V	2 mA
Total backplane power	0.9 W
Power dissipation, max	6.1 W @ 60 °C (140 °F)
Thermal dissipation	20.8 BTU/hr
Off-state voltage, max	20V
Off-state current, max	2.5 mA
On-state current, min	5 mA @ 74V AC
On-state current, max	15 mA @ 132V AC
Inrush current, max	390 mA
Input impedance, max	14.0 kΩ @ 132V AC, 60 Hz

Technical Specifications - 1756-IA32

Attribute	1756-IA32
Cyclic update time	200 μ s...750 ms
Change of state	Software configurable
Timestamp of inputs	\pm 200 μ s
Isolation voltage	250V (continuous), basic insulation type, inputs-to-backplane 125V (continuous), basic insulation type, input group-to-group No isolation between individual group inputs Routine tested @ 1350V AC for 2 s
Module keying	Electronic, software configurable
Removable terminal block housing	1756-TBCH 1756-TBS6H
RTB keying	User-defined mechanical
Slot width	1
Wire category	1 ⁽¹⁾
North American temperature code	T4
Enclosure type	None (open-style)

(1) Use this conductor category information for planning conductor routing as described in the system-level installation manual. See the Industrial Automation Wiring and Grounding Guidelines, publication [1770-4.1](#).

Environmental Specifications - 1756-IA32

Attribute	1756-IA32
Temperature, operating IEC 60068-2-1 (Test Ad, Operating Cold), IEC 60068-2-2 (Test Bd, Operating Dry Heat), IEC 60068-2-14 (Test Nb, Operating Thermal Shock)	0...60 °C (32...140 °F)
Temperature, surrounding air, max	60 °C (140 °F)
Temperature, storage IEC 60068-2-1 (Test Ab, Unpackaged Nonoperating Cold), IEC 60068-2-2 (Test Bb, Unpackaged Nonoperating Dry Heat), IEC 60068-2-14 (Test Na, Unpackaged Nonoperating Thermal Shock)	-40...85 °C (-40...185 °F)
Relative humidity IEC 60068-2-30 (Test Db, Unpackaged Nonoperating Damp Heat)	5...95% noncondensing
Vibration IEC 60068-2-6 (Test Fc, Operating)	2 g @ 10...500 Hz
Shock, operating IEC 60068-2-27 (Test Ea, Unpackaged Shock)	30 g
Shock, nonoperating IEC 60068-2-27 (Test Ea, Unpackaged Shock)	50 g
Emissions	CISPR 11: Group 1, Class A
ESD immunity IEC 61000-4-2	6 kV contact discharges 8 kV air discharges
Radiated RF immunity IEC 61000-4-3	10V/m with 1 kHz sine-wave 80% AM from 80...2000 MHz 10V/m with 200 Hz 50% Pulse 100% AM @ 900 MHz 10V/m with 200 Hz 50% Pulse 100% AM @ 1890 MHz 3V/m with 1 kHz sine-wave 80% AM from 2000...2700 MHz

Environmental Specifications - 1756-IA32

Attribute	1756-IA32
EFT/B immunity IEC 61000-4-4	±4 kV at 5 kHz on signal ports
Surge transient immunity IEC 61000-4-5	±1 kV line-line (DM) and ±2 kV line-earth (CM) on signal ports
Conducted RF immunity IEC 61000-4-6	10V rms with 1 kHz sine-wave 80% AM from 150 kHz...80 MHz

Certifications - 1756-IA32

Certification ⁽¹⁾	1756-IA32
UL	UL Listed Industrial Control Equipment, certified for US and Canada. See UL File E65584.
CSA	CSA Certified Process Control Equipment. See CSA File LR54689C. CSA Certified Process Control Equipment for Class I, Division 2 Group A,B,C,D Hazardous Locations. See CSA File LR69960C.
CE	European Union 2004/108/IEC EMC Directive, compliant with: <ul style="list-style-type: none"> • EN 61326-1; Meas./Control/Lab., Industrial Requirements • EN 61000-6-2; Industrial Immunity • EN 61000-6-4; Industrial Emissions • EN 61131-2; Programmable Controllers (Clause 8, Zone A & B) European Union 2006/95/EC LVD, compliant with: <ul style="list-style-type: none"> • EN 61131-2; Programmable Controllers (Clause 11)
C-Tick	Australian Radiocommunications Act, compliant with: AS/NZS CISPR 11; Industrial Emissions

(1) When marked. See the Product Certification link at <http://www.ab.com> for Declarations of Conformity, Certificates, and other certification details.

1756-IB16

ControlLogix DC (10...31.2V) input module

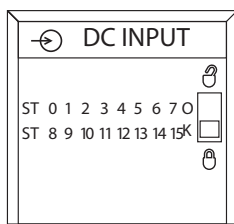
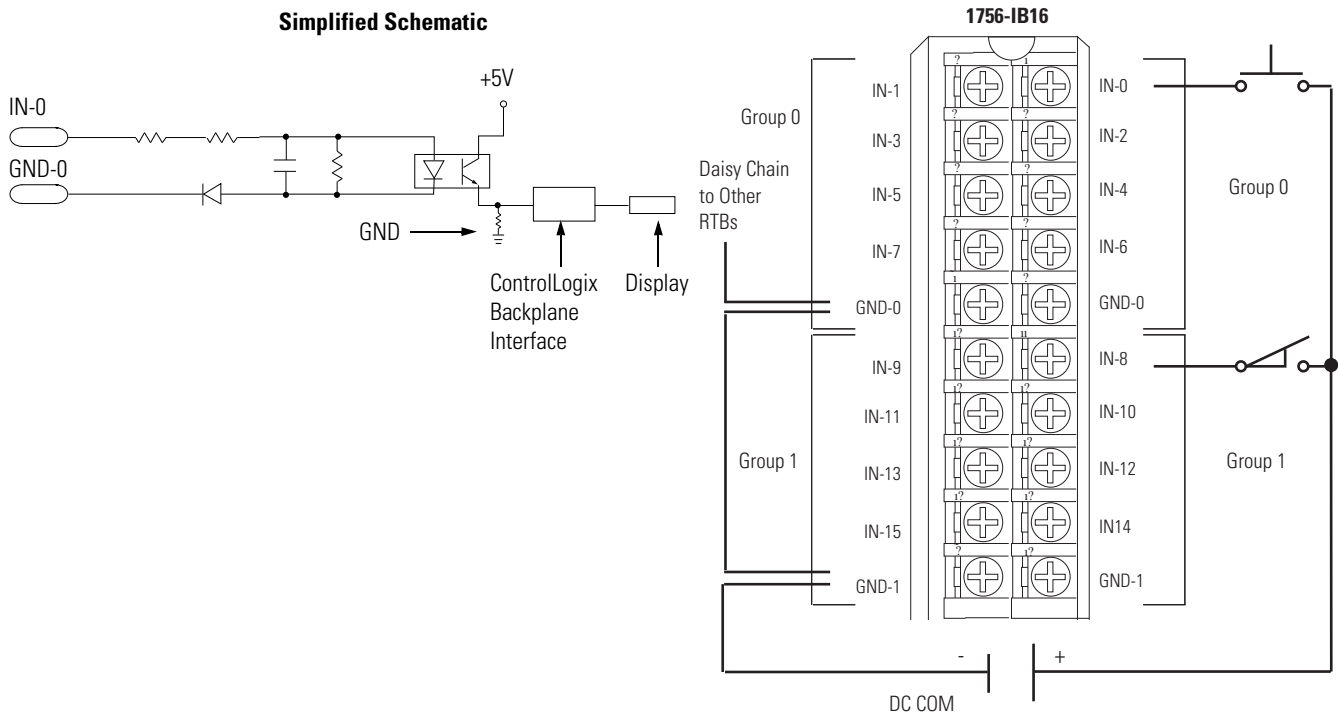

Technical Specifications - 1756-IB16

Attribute	1756-IB16
Inputs	16 (8 points/group)
Voltage category	12/24V DC sink
Operating voltage range	10...31.2V DC
Input voltage, nom	24V DC
Input delay time OFF to ON	Hardware delay: 290 μ s nom/1 ms max + filter time User-selectable filter time: 0, 1, or 2 ms
ON to OFF	Hardware delay: 700 μ s nom/2 ms max + filter time User-selectable filter time: 0, 1, 2, 9, or 18 ms
Current draw @ 5.1V	100 mA
Current draw @ 24V	2 mA
Total backplane power	0.56 W
Power dissipation, max	5.1 W @ 60 °C (140 °F)
Thermal dissipation	17.39 BTU/hr
Off-state voltage, max	5V
Off-state current, max	1.5 mA
On-state current, min	2 mA @ 10V DC
On-state current, max	10 mA @ 31.2V DC

Technical Specifications - 1756-IB16

Attribute	1756-IB16
Inrush current, max	250 mA peak (decaying to < 37% in 22 ms, without activation)
Input impedance, max	3.12 k Ω @ 31.2V DC
Cyclic update time	200 μ s...750 ms
Change of state	Software configurable
Timestamp of inputs	\pm 200 μ s
Isolation voltage	250V (continuous), basic insulation type, inputs-to-backplane, and input group-to-group No isolation between individual group inputs Routine tested @ 1350V AC for 2 s
Module keying	Electronic, software configurable
Removable terminal block housing	1756-TBNH 1756-TBSH
RTB keying	User-defined mechanical
Slot width	1
Wire category	1 ⁽¹⁾
North American temperature code	T3C
IEC temperature code	T3
Enclosure type	None (open-style)
Reverse polarity protection	Yes

(1) Use this conductor category information for planning conductor routing as described in the system-level installation manual. See the Industrial Automation Wiring and Grounding Guidelines, publication [1770-4.1](#).

Environmental Specifications - 1756-IB16

Attribute	1756-IB16
Temperature, operating IEC 60068-2-1 (Test Ad, Operating Cold), IEC 60068-2-2 (Test Bd, Operating Dry Heat), IEC 60068-2-14 (Test Nb, Operating Thermal Shock)	0...60 °C (32...140 °F)
Temperature, surrounding air, max	60 °C (140 °F)
Temperature, storage IEC 60068-2-1 (Test Ab, Unpackaged Nonoperating Cold), IEC 60068-2-2 (Test Bb, Unpackaged Nonoperating Dry Heat), IEC 60068-2-14 (Test Na, Unpackaged Nonoperating Thermal Shock)	-40...85 °C (-40...185 °F)
Relative humidity IEC 60068-2-30 (Test Db, Unpackaged Nonoperating Damp Heat)	5...95% noncondensing
Vibration IEC 60068-2-6 (Test Fc, Operating)	2 g @ 10...500 Hz
Shock, operating IEC 60068-2-27 (Test Ea, Unpackaged Shock)	30 g
Shock, nonoperating IEC 60068-2-27 (Test Ea, Unpackaged Shock)	50 g
Emissions	CISPR 11: Group 1, Class A
ESD immunity IEC 61000-4-2	6 kV contact discharges 8 kV air discharges
Radiated RF immunity IEC 61000-4-3	10V/m with 1kHz sine-wave 80% AM from 80... 2000 MHz 10V/m with 200Hz 50% Pulse 100% AM @ 900 MHz 10V/m with 200Hz 50% Pulse 100% AM @ 1890 MHz 3V/m with 1kHz sine-wave 80% AM from 2000...2700 MHz

Environmental Specifications - 1756-IB16

Attribute	1756-IB16
EFT/B immunity IEC 61000-4-4	±4 kV at 5 kHz on signal ports
Surge transient immunity IEC 61000-4-5	±1 kV line-line (DM) and ±2 kV line-earth (CM) on signal ports
Conducted RF immunity IEC 61000-4-6	10V rms with 1 kHz sine-wave 80% AM from 150 kHz...80 MHz
Oscillatory surge withstand IEEE C37.90.1	3 kV

Certifications - 1756-IB16

Certification ⁽¹⁾	1756-IB16
UL	UL Listed Industrial Control Equipment, certified for US and Canada. See UL File E65584.
CSA	CSA Certified Process Control Equipment. See CSA File LR54689C. CSA Certified Process Control Equipment for Class I, Division 2 Group A,B,C,D Hazardous Locations. See CSA File LR69960C.
CE	European Union 2004/108/IEC EMC Directive, compliant with: <ul style="list-style-type: none"> • EN 61326-1; Meas./Control/Lab., Industrial Requirements • EN 61000-6-2; Industrial Immunity • EN 61000-6-4; Industrial Emissions • EN 61131-2; Programmable Controllers (Clause 8, Zone A & B) European Union 2006/95/EC LVD, compliant with: <ul style="list-style-type: none"> • EN 61131-2; Programmable Controllers (Clause 11)
C-Tick	Australian Radiocommunications Act, compliant with: AS/NZS CISPR 11; Industrial Emissions
Ex	European Union 94/9/EC ATEX Directive, compliant with: <ul style="list-style-type: none"> • EN 60079-15; Potentially Explosive Atmospheres, Protection "n" • EN 60079-0; General Requirements II 3 G Ex nA IIC T3 X
FM	FM Approved Equipment for use in Class I Division 2 Group A,B,C,D Hazardous Locations

(1) When marked. See the Product Certification link at <http://www.ab.com> for Declarations of Conformity, Certificates, and other certification details.

1756-IB16D

ControlLogix DC (10...30V) diagnostic input module

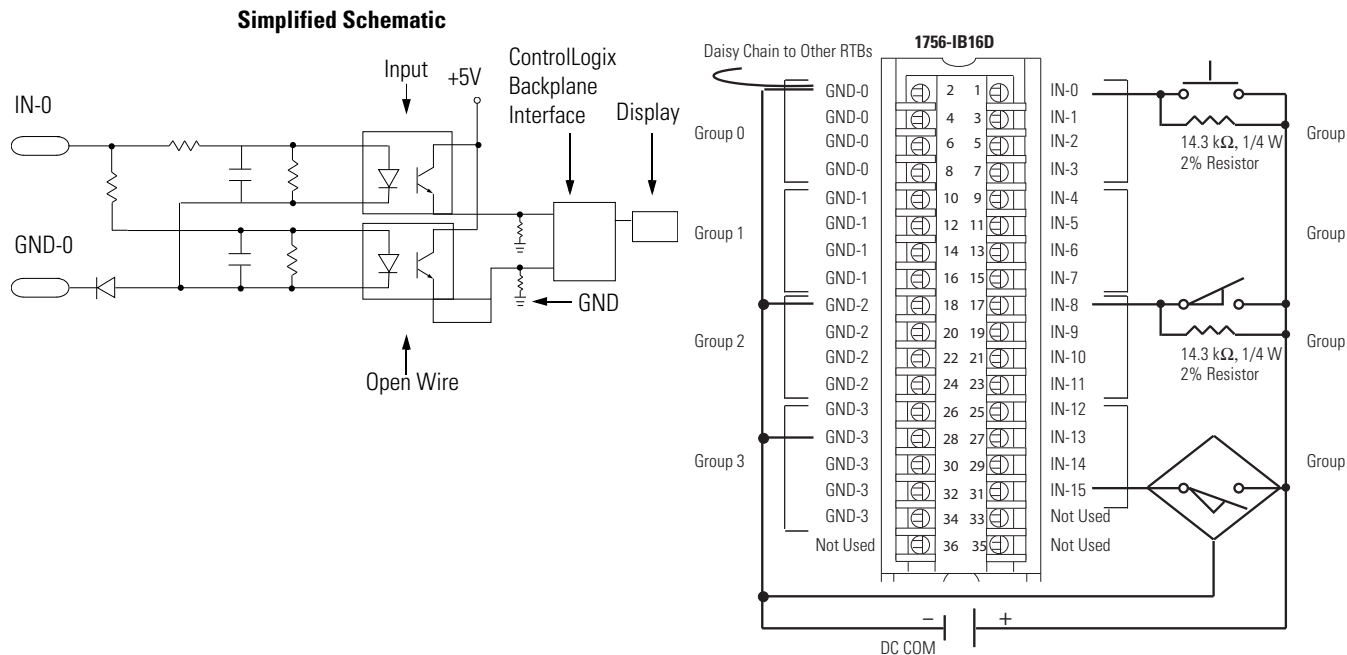

Diagnostic Specifications - 1756-IB16D

Attribute	1756-IB16D
Open wire	Off-state leakage current 1.2 mA min
Timestamp of diagnostics	±1 ms

Technical Specifications - 1756-IB16D

Attribute	1756-IB16D
Inputs	16 diagnostic (4 points/group)
Voltage category	12/24V DC sink
Operating voltage range	10 ... 30V DC
Input voltage, nom	24V DC
Input delay time OFF to ON	Hardware delay: 340 μs nom/1 ms max + filter time User-selectable filter time: 0, 1, or 2 ms
ON to OFF	Hardware delay: 740 μs nom/4 ms max + filter time User-selectable filter time: 0, 1, 9, or 18 ms
Current draw @ 5.1V	150 mA
Current draw @ 24V	3 mA
Total backplane power	0.84 W
Power dissipation, max	5.8 W @ 60 °C (140 °F)
Thermal dissipation	19.78 BTU/hr

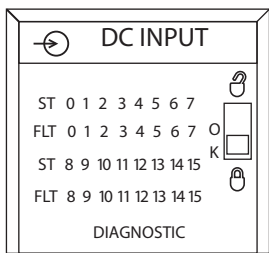

Technical Specifications - 1756-IB16D

Attribute	1756-IB16D
Off-state voltage, max	5V
Off-state current, max	1.5 mA
On-state current, min	2 mA @ 10V DC
On-state current, max	13 mA @ 30V DC
Inrush current, max	250 mA
Input impedance, max	2.31 k Ω @ 30V DC
Cyclic update time	200 μ s...750 ms
Change of state	Software configurable
Timestamp of inputs	\pm 200 μ s
Isolation voltage	250V (continuous), basic insulation type, inputs-to-backplane, and input group-to-group No isolation between individual group inputs Routine tested @ 1350V AC for 2 s
Module keying	Electronic, software configurable
Removable terminal block housing	1756-TBCH 1756-TBS6H
RTB keying	User-defined mechanical
Slot width	1
Wire category	1 ⁽¹⁾
North American temperature code	T3C
IEC temperature code	T3
Enclosure type	None (open-style)
Reverse polarity protection	Yes

(1) Use this conductor category information for planning conductor routing as described in the system-level installation manual. See the Industrial Automation Wiring and Grounding Guidelines, publication [1770-4.1](#).

Environmental Specifications - 1756-IB16D

Attribute	1756-IB16D
Temperature, operating IEC 60068-2-1 (Test Ad, Operating Cold), IEC 60068-2-2 (Test Bd, Operating Dry Heat), IEC 60068-2-14 (Test Nb, Operating Thermal Shock)	0...60 °C (32...140 °F)
Temperature, surrounding air, max	60 °C (140 °F)
Temperature, storage IEC 60068-2-1 (Test Ab, Unpackaged Nonoperating Cold), IEC 60068-2-2 (Test Bb, Unpackaged Nonoperating Dry Heat), IEC 60068-2-14 (Test Na, Unpackaged Nonoperating Thermal Shock)	-40...85 °C (-40...185 °F)
Relative humidity IEC 60068-2-30 (Test Db, Unpackaged Nonoperating Damp Heat)	5...95% noncondensing
Vibration IEC 60068-2-6 (Test Fc, Operating)	2 g @ 10...500 Hz
Shock, operating IEC 60068-2-27 (Test Ea, Unpackaged Shock)	30 g
Shock, nonoperating IEC 60068-2-27 (Test Ea, Unpackaged Shock)	50 g
Emissions	CISPR 11: Group 1, Class A

Environmental Specifications - 1756-IB16D

Attribute	1756-IB16D
ESD immunity IEC 61000-4-2	6 kV contact discharges 8 kV air discharges
Radiated RF immunity IEC 61000-4-3	10V/m with 1 kHz sine-wave 80% AM from 80... 2000 MHz 10V/m with 200 Hz 50% Pulse 100% AM @ 900 MHz 10V/m with 200 Hz 50% Pulse 100% AM @ 1890 MHz 3V/m with 1 kHz sine-wave 80% AM from 2000...2700 MHz
EFT/B immunity IEC 61000-4-4	±4 kV at 5 kHz on signal ports
Surge transient immunity IEC 61000-4-5	±1 kV line-line (DM) and ±2 kV line-earth (CM) on signal ports
Conducted RF immunity IEC 61000-4-6	10V rms with 1 kHz sine-wave 80% AM from 150 kHz...80 MHz

Certifications - 1756-IB16D

Certifications ⁽¹⁾	1756-IB16D
UL	UL Listed Industrial Control Equipment, certified for US and Canada. See UL File E65584.
CSA	CSA Certified Process Control Equipment. See CSA File LR54689C. CSA Certified Process Control Equipment for Class I, Division 2 Group A,B,C,D Hazardous Locations. See CSA File LR69960C.
CE	European Union 2004/108/IEC EMC Directive, compliant with: <ul style="list-style-type: none"> • EN 61326-1; Meas./Control/Lab., Industrial Requirements • EN 61000-6-2; Industrial Immunity • EN 61000-6-4; Industrial Emissions • EN 61131-2; Programmable Controllers (Clause 8, Zone A & B) European Union 2006/95/EC LVD, compliant with: <ul style="list-style-type: none"> • EN 61131-2; Programmable Controllers (Clause 11)
C-Tick	Australian Radiocommunications Act, compliant with: AS/NZS CISPR 11; Industrial Emissions
Ex	European Union 94/9/EC ATEX Directive, compliant with: <ul style="list-style-type: none"> • EN 60079-15; Potentially Explosive Atmospheres, Protection "n" • EN 60079-0; General Requirements II 3 G Ex nA IIC T3 X
FM	FM Approved Equipment for use in Class I Division 2 Group A,B,C,D Hazardous Locations
TÜV	TÜV Certified for Functional Safety ⁽²⁾ : Capable of SIL 2

(1) When marked. See the Product Certification link at <http://www.ab.com> for Declarations of Conformity, Certificates, and other certification details.

(2) When used with specified firmware revisions and in accordance with application guidelines described in Using ControlLogix in SIL2 Applications Safety Reference Manual, publication [1756-RM001](#).

1756-IB16I

ControlLogix DC (10...30V) isolated input module

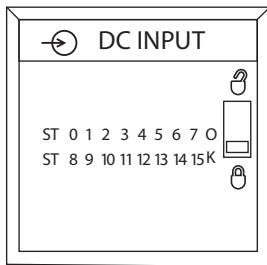
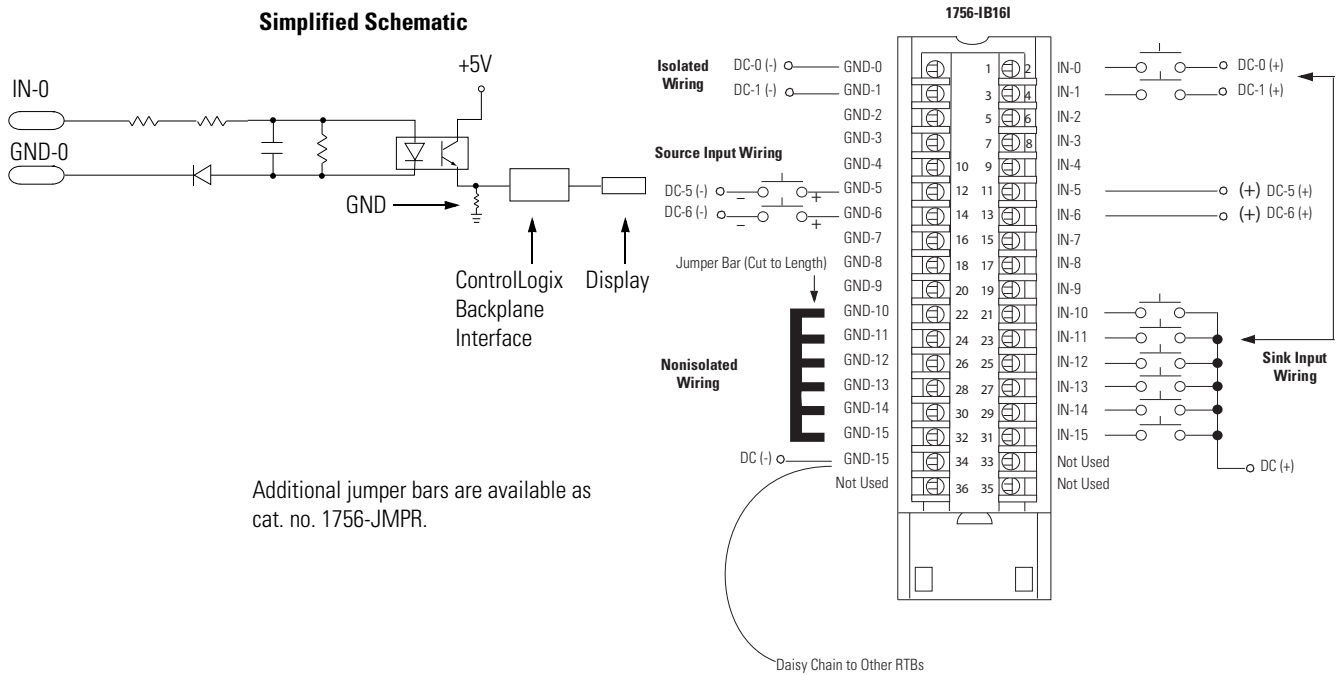

Technical Specifications - 1756-IB16I

Attribute	1756-IB16I
Inputs	16 individually isolated
Voltage category	12/24V DC sink/source
Operating voltage range	10...30V DC
Input voltage, nom	24V DC
Input delay time OFF to ON	Hardware delay: 1 ms max + filter time User-selectable filter time: 0, 1, or 2 ms
ON to OFF	Hardware delay: 4 ms max + filter time User-selectable filter time: 0, 1, 2, 9, or 18 ms
Current draw @ 5.1V	100 mA
Current draw @ 24V	3 mA
Total backplane power	0.58 W
Power dissipation, max	5 W @ 60 °C (140 °F)
Thermal dissipation	17.05 BTU/hr
Off-state voltage, max	5V
Off-state current, max	1.5 mA
On-state current, min	2 mA @ 10 V DC
On-state current, max	10 mA @ 30V DC
Inrush current, max	250 mA peak (decaying to < 37% in 22 ms, without activation)

Technical Specifications - 1756-IB16I

Attribute	1756-IB16I
Input impedance, max	3 k Ω @ 30V DC
Cyclic update time	200 μ s...750 ms
Change of state	Software configurable
Timestamp of inputs	\pm 200 μ s
Isolation voltage	250V (continuous), basic insulation type, inputs-to-backplane, and input-to-input Routine tested @ 1350V AC for 2 s
Module keying	Electronic, software configurable
Removable terminal block housing	1756-TBCH 1756-TBS6H
RTB keying	User-defined mechanical
Slot width	1
Wire category	1 ⁽¹⁾
North American temperature code	T4
IEC temperature code	T4
Enclosure type	None (open-style)
Reverse polarity protection	Yes

(1) Use this conductor category information for planning conductor routing as described in the system-level installation manual. See the Industrial Automation Wiring and Grounding Guidelines, publication [1770-4.1](#).

Environmental Specifications - 1756-IB16I

Attribute	1756-IB16I
Temperature, operating IEC 60068-2-1 (Test Ad, Operating Cold), IEC 60068-2-2 (Test Bd, Operating Dry Heat), IEC 60068-2-14 (Test Nb, Operating Thermal Shock)	0...60 °C (32...140 °F)
Temperature, surrounding air, max	60 °C (140 °F)
Temperature, storage IEC 60068-2-1 (Test Ab, Unpackaged Nonoperating Cold), IEC 60068-2-2 (Test Bb, Unpackaged Nonoperating Dry Heat), IEC 60068-2-14 (Test Na, Unpackaged Nonoperating Thermal Shock)	-40...85 °C (-40...185 °F)
Relative humidity IEC 60068-2-30 (Test Db, Unpackaged Nonoperating Damp Heat)	5...95% noncondensing
Vibration IEC 60068-2-6 (Test Fc, Operating)	2 g @ 10...500 Hz
Shock, operating IEC 60068-2-27 (Test Ea, Unpackaged Shock)	30 g
Shock, nonoperating IEC 60068-2-27 (Test Ea, Unpackaged Shock)	50 g
Emissions	CISPR 11: Group 1, Class A
ESD immunity IEC 61000-4-2	6 kV contact discharges 8 kV air discharges
Radiated RF immunity IEC 61000-4-3	10V/m with 1 kHz sine-wave 80% AM from 80... 2000 MHz 10V/m with 200 Hz 50% Pulse 100% AM @ 900 MHz 10V/m with 200 Hz 50% Pulse 100% AM @ 1890 MHz 3V/m with 1 kHz sine-wave 80% AM from 2000...2700 MHz
EFT/B immunity IEC 61000-4-4	\pm 4 kV at 5 kHz on signal ports

Environmental Specifications - 1756-IB16I

Attribute	1756-IB16I
Surge transient immunity IEC 61000-4-5	±1 kV line-line (DM) and ±2 kV line-earth (CM) on signal ports
Conducted RF immunity IEC 61000-4-6	10V rms with 1 kHz sine-wave 80% AM from 150 kHz...80 MHz
Oscillatory surge withstand IEEE C37.90.1	3 kV

Certifications - 1756-IB16I

Certification ⁽¹⁾	1756-IB16I
UL	UL Listed Industrial Control Equipment, certified for US and Canada. See UL File E65584.
CSA	CSA Certified Process Control Equipment. See CSA File LR54689C. CSA Certified Process Control Equipment for Class I, Division 2 Group A,B,C,D Hazardous Locations. See CSA File LR69960C.
CE	European Union 2004/108/IEC EMC Directive, compliant with: <ul style="list-style-type: none"> • EN 61326-1; Meas./Control/Lab., Industrial Requirements • EN 61000-6-2; Industrial Immunity • EN 61000-6-4; Industrial Emissions • EN 61131-2; Programmable Controllers (Clause 8, Zone A & B) European Union 2006/95/EC LVD, compliant with: <ul style="list-style-type: none"> • EN 61131-2; Programmable Controllers (Clause 11)
C-Tick	Australian Radiocommunications Act, compliant with: AS/NZS CISPR 11; Industrial Emissions
Ex	European Union 94/9/EC ATEX Directive, compliant with: <ul style="list-style-type: none"> • EN 60079-15; Potentially Explosive Atmospheres, Protection "n" • EN 60079-0; General Requirements II 3 G Ex nA IIC T4 X
FM	FM Approved Equipment for use in Class I Division 2 Group A,B,C,D Hazardous Locations
TÜV	TÜV Certified for Functional Safety ⁽²⁾ : Capable of SIL 2

(1) When marked. See the Product Certification link at <http://www.ab.com> for Declarations of Conformity, Certificates, and other certification details.

(2) When used with specified firmware revisions and in accordance with application guidelines described in Using ControlLogix in SIL2 Applications Safety Reference Manual, publication [1756-RM001](#).

1756-IB16ISOE

ControlLogix DC (10...55V) sequence of events input module

Simplified Schematic

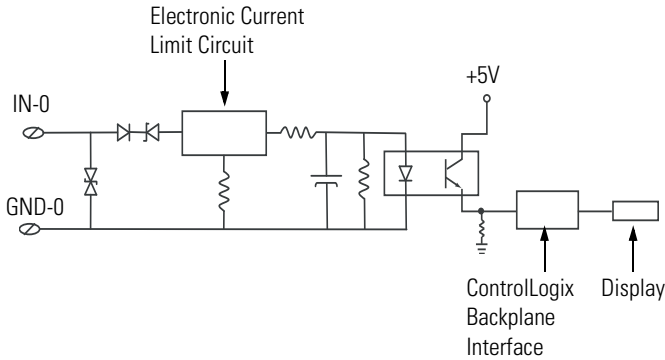

Additional jumper bars are available as cat. no. 1756-JMPR.

1756-IB16ISOE

Isolated Wiring

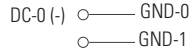

Source Input Wiring



Nonisolated Wiring

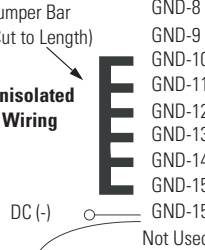

Daisy Chain to Other RTBs

Sink Input Wiring

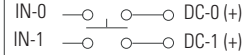

Source Input Wiring

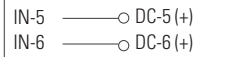

Sink Input Wiring

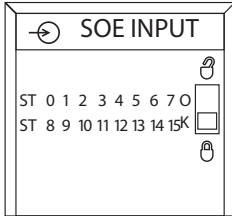
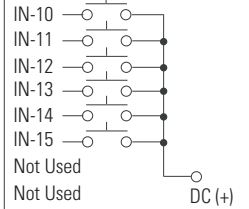

Technical Specifications - 1756-IB16ISOE

Attribute	1756-IB16ISOE
Inputs	16 individually isolated, sequence of events
Voltage category	24/48V DC sink/source
Operating voltage range	10 ... 55V DC
Input voltage, nom	24V DC
Input delay time OFF to ON	Hardware delay: 10 μs nom/20 μs max + firmware scan: up to 25 μs + filter time: 0...50 ms + ASIC delay: 175 μs (FIFO) or 625 μs (Coordinated System Time per point)
ON to OFF	Hardware delay: 25 μs nom/50 μs max + firmware scan: up to 25 μs + filter time: (0...50 ms + ASIC delay: 175 μs (FIFO) or 625 μs (Coordinated System Time per point)
Current draw @ 5.1V	320 mA\$
Current draw @ 24V	2 mA
Total backplane power	1.7 W
Power dissipation, max	5.5 W @ 60 °C (140 °F)
Thermal dissipation	17.22 BTU/hr
Off-state voltage, max	5V
Off-state current, max	1.5 mA
On-state current, min	2.0 mA @ 9V DC
On-state current, nom	4.5 mA @ 24...31V DC

Technical Specifications - 1756-IB16ISOE

Attribute	1756-IB16ISOE
On-state current, max	5.1 mA @ 48...55V DC
Input impedance, max	10.8 k Ω @ 55V DC
Cyclic update time	200 μ s...750 ms
Change of state	Software configurable
Timestamp of inputs	\pm 100 μ s
Isolation voltage	250V (continuous), basic insulation type, inputs-to-backplane 125V (continuous), basic insulation type, input-to-input Routine tested @ 1350V AC for 2 s
Module keying	Electronic, software configurable
Removable terminal block	1756-TBCH 1756-TBS6H
RTB keying	User-defined mechanical
Slot width	1
Wire category	1 ⁽¹⁾
North American temperature code	T4
Enclosure type	None (open-style)
Reverse polarity protection	Yes

(1) Use this conductor category information for planning conductor routing as described in the system-level installation manual. See the Industrial Automation Wiring and Grounding Guidelines, publication [1770-4.1](#).

Environmental Specifications - 1756-IB16ISOE

Attribute	1756-IB16ISOE
Temperature, operating IEC 60068-2-1 (Test Ad, Operating Cold), IEC 60068-2-2 (Test Bd, Operating Dry Heat), IEC 60068-2-14 (Test Nb, Operating Thermal Shock)	0...60 °C (32...140 °F)
Temperature, surrounding air, max	60 °C (140 °F)
Temperature, storage IEC 60068-2-1 (Test Ab, Unpackaged Nonoperating Cold), IEC 60068-2-2 (Test Bb, Unpackaged Nonoperating Dry Heat), IEC 60068-2-14 (Test Na, Unpackaged Nonoperating Thermal Shock)	-40...85 °C (-40...185 °F)
Relative humidity IEC 60068-2-30 (Test Db, Unpackaged Nonoperating Damp Heat)	5...95% noncondensing
Vibration IEC 60068-2-6 (Test Fc, Operating)	2 g @ 10...500 Hz
Shock, operating IEC 60068-2-27 (Test Ea, Unpackaged Shock)	30 g
Shock, nonoperating IEC 60068-2-27 (Test Ea, Unpackaged Shock)	50 g
Emissions	CISPR 11: Group 1, Class A
ESD immunity IEC 61000-4-2	6 kV contact discharges 8 kV air discharges
Radiated RF immunity IEC 61000-4-3	10V/m with 1 kHz sine-wave 80% AM from 80...2000 MHz 10V/m with 200 Hz 50% Pulse 100% AM @ 900 MHz 10V/m with 200 Hz 50% Pulse 100% AM @ 1890 MHz 3V/m with 1 kHz sine-wave 80% AM from 2000...2700 MHz
EFT/B immunity IEC 61000-4-4	\pm 4 kV at 5 kHz on signal ports

Environmental Specifications - 1756-IB16ISOE

Attribute	1756-IB16ISOE
Surge transient immunity IEC 61000-4-5	± 1 kV line-line (DM) and ± 2 kV line-earth (CM) on signal ports
Conducted RF immunity IEC 61000-4-6	10V rms with 1 kHz sine-wave 80% AM from 150 kHz...80 MHz
Oscillatory surge withstand IEEE C37.90.1	2.5 kV

Certifications - 1756-IB16ISOE

Certification ⁽¹⁾	1756-IB16ISOE
UL	UL Listed Industrial Control Equipment, certified for US and Canada. See UL File E65584.
CSA	CSA Certified Process Control Equipment. See CSA File LR54689C. CSA Certified Process Control Equipment for Class I, Division 2 Group A,B,C,D Hazardous Locations. See CSA File LR69960C.
CE	European Union 2004/108/IEC EMC Directive, compliant with: <ul style="list-style-type: none"> • EN 61326-1; Meas./Control/Lab., Industrial Requirements • EN 61000-6-2; Industrial Immunity • EN 61000-6-4; Industrial Emissions • EN 61131-2; Programmable Controllers (Clause 8, Zone A & B) European Union 2006/95/EC LVD, compliant with: <ul style="list-style-type: none"> • EN 61131-2; Programmable Controllers (Clause 11)
C-Tick	Australian Radiocommunications Act, compliant with: AS/NZS CISPR 11; Industrial Emissions
TÜV	TÜV Certified for Functional Safety ⁽²⁾ : Capable of SIL 2

(1) When marked. See the Product Certification link at <http://www.ab.com> for Declarations of Conformity, Certificates, and other certification details.

(2) When used with specified firmware revisions and in accordance with application guidelines described in Using ControlLogix in SIL2 Applications Safety Reference Manual, publication [1756-RM001](#).

1756-IB32

ControlLogix DC (10...31.2V) input module

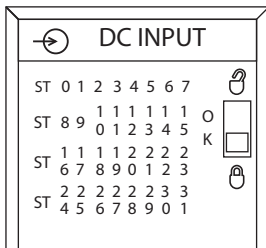
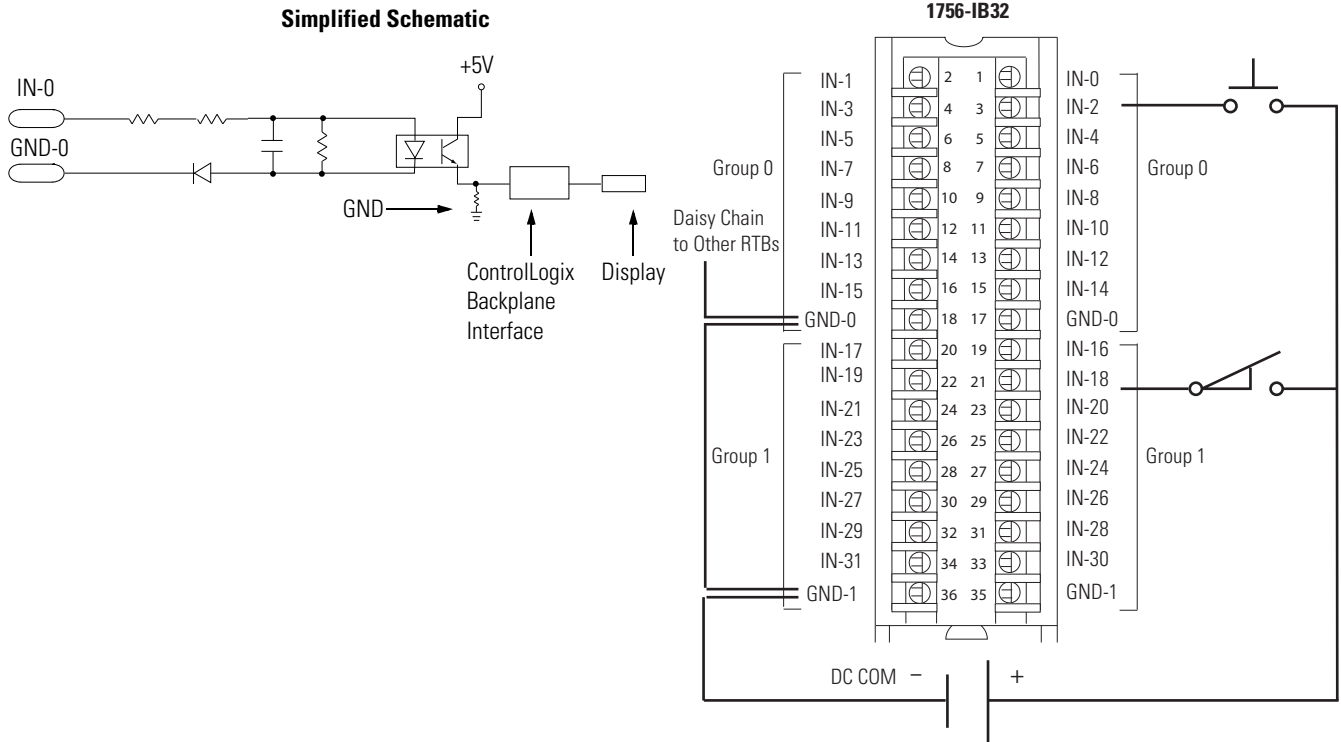

Technical Specifications - 1756-IB32

Attribute	1756-IB32
Inputs	32 (16 points/group)
Voltage category	12/24V DC sink
Operating voltage range	10...31.2V DC
Input voltage, nom	24V DC
Input delay time OFF to ON	Hardware delay: 380 μs max + filter time User-selectable filter time: 0, 1, or 2 ms
ON to OFF	Hardware delay: 420 μs max + filter time User-selectable filter time: 0, 1, 2, 9, or 18 ms
Current draw @ 5.1V	120 mA
Current draw @ 24V	2 mA
Total backplane power	0.66 W
Power dissipation, max	6.2 W @ 60 °C (140 °F)
Thermal dissipation	21.1 BTU/hr @ 60 °C (140 °F)
Off-state voltage, max	5V
Off-state current, max	2.27 mA
On-state current, min	4.8 mA @ 10V DC
On-state current, max	5.5 mA @ 31.2V DC
Inrush current, max	250 mA (decaying to < 37% in 22 ms, without activation)

Technical Specifications - 1756-IB32

Attribute	1756-IB32
Input impedance, max	5.67 k Ω @ 31.2V DC
Cyclic update time	200 μ s...750 ms
Change of state	Software configurable
Timestamp of inputs	\pm 200 μ s
Isolation voltage	250V (continuous), reinforced insulation type, inputs-to-backplane 250V (continuous), basic insulation type, input group-to-group No isolation between individual group inputs Routine tested @ 1350V AC for 2 s
Module keying	Electronic, software configurable
Removable terminal block	1756-TBCH 1756-TBS6H
RTB keying	User-defined mechanical
Slot width	1
Wire category	1 - on signal ports ⁽¹⁾
North American temperature code	T4
IEC temperature code	T4
Enclosure type	None (open-style)
Reverse polarity protection	Yes

(1) Use this conductor category information for planning conductor routing as described in the system-level installation manual. See the Industrial Automation Wiring and Grounding Guidelines, publication [1770-4.1](#).

Environmental Specifications - 1756-IB32

Attribute	1756-IB32
Temperature, operating IEC 60068-2-1 (Test Ad, Operating Cold), IEC 60068-2-2 (Test Bd, Operating Dry Heat), IEC 60068-2-14 (Test Nb, Operating Thermal Shock)	0...60 °C (32...140 °F)
Temperature, surrounding air, max	60 °C (140 °F)
Temperature, storage IEC 60068-2-1 (Test Ab, Unpackaged Nonoperating Cold), IEC 60068-2-2 (Test Bb, Unpackaged Nonoperating Dry Heat), IEC 60068-2-14 (Test Na, Unpackaged Nonoperating Thermal Shock)	-40...85 °C (-40...185 °F)
Relative humidity IEC 60068-2-30 (Test Db, Unpackaged Nonoperating Damp Heat)	5...95% noncondensing
Vibration IEC 60068-2-6 (Test Fc, Operating)	2 g @ 10...500 Hz
Shock, operating IEC 60068-2-27 (Test Ea, Unpackaged Shock)	30 g
Shock, nonoperating IEC 60068-2-27 (Test Ea, Unpackaged Shock)	50 g
Emissions	CISPR 11: Group 1, Class A
ESD immunity IEC 61000-4-2	6 kV contact discharges 8 kV air discharges
Radiated RF immunity IEC 61000-4-3	10V/m with 1 kHz sine-wave 80% AM from 80... 2000 MHz 10V/m with 200 Hz 50% Pulse 100% AM @ 900 MHz 10V/m with 200 Hz 50% Pulse 100% AM @ 1890 MHz 3V/m with 1 kHz sine-wave 80% AM from 2000...2700 MHz

Environmental Specifications - 1756-IB32

Attribute	1756-IB32
EFT/B immunity IEC 61000-4-4	±4 kV at 5 kHz on signal ports
Surge transient immunity IEC 61000-4-5	±1 kV line-line (DM) and ±2 kV line-earth (CM) on signal ports
Conducted RF immunity IEC 61000-4-6	10V rms with 1 kHz sine-wave 80% AM from 150 kHz...80 MHz
Oscillatory surge withstand IEEE C37.90.1	3 kV

Certifications - 1756-IB32

Certification ⁽¹⁾	1756-IB32
c-UL-us	UL Listed Industrial Control Equipment, certified for US and Canada. See UL File E65584. UL Listed for Class I, Division 2 Group A,B,C,D Hazardous Locations, certified for U.S. and Canada. See UL File E194810.
CSA	CSA Certified Process Control Equipment. See CSA File LR54689C. CSA Certified Process Control Equipment for Class I, Division 2 Group A,B,C,D Hazardous Locations. See CSA File LR69960C.
CE	European Union 2004/108/IEC EMC Directive, compliant with: <ul style="list-style-type: none"> • EN 61326-1; Meas./Control/Lab., Industrial Requirements • EN 61000-6-2; Industrial Immunity • EN 61000-6-4; Industrial Emissions • EN 61131-2; Programmable Controllers (Clause 8, Zone A & B) European Union 2006/95/EC LVD, compliant with: <ul style="list-style-type: none"> • EN 61131-2; Programmable Controllers (Clause 11)
C-Tick	Australian Radiocommunications Act, compliant with: AS/NZS CISPR 11; Industrial Emissions
Ex	European Union 94/9/EC ATEX Directive, compliant with: <ul style="list-style-type: none"> • EN 60079-15; Potentially Explosive Atmospheres, Protection "n" • EN 60079-0; General Requirements II 3 G Ex nA IIC T4 X
FM	FM Approved Equipment for use in Class I Division 2 Group A,B,C,D Hazardous Locations
TÜV	TÜV Certified for Functional Safety ⁽²⁾ . Capable of SIL 2

(1) When marked. See the Product Certification link at <http://www.ab.com> for Declarations of Conformity, Certificates, and other certification details.

(2) When used with specified firmware revisions and in accordance with application guidelines described in Using ControlLogix in SIL2 Applications Safety Reference Manual, publication [1756-RM001](#).

1756-IC16

ControlLogix DC (30...60V) input module

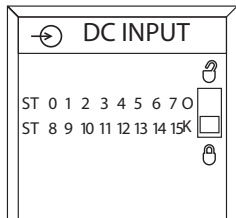
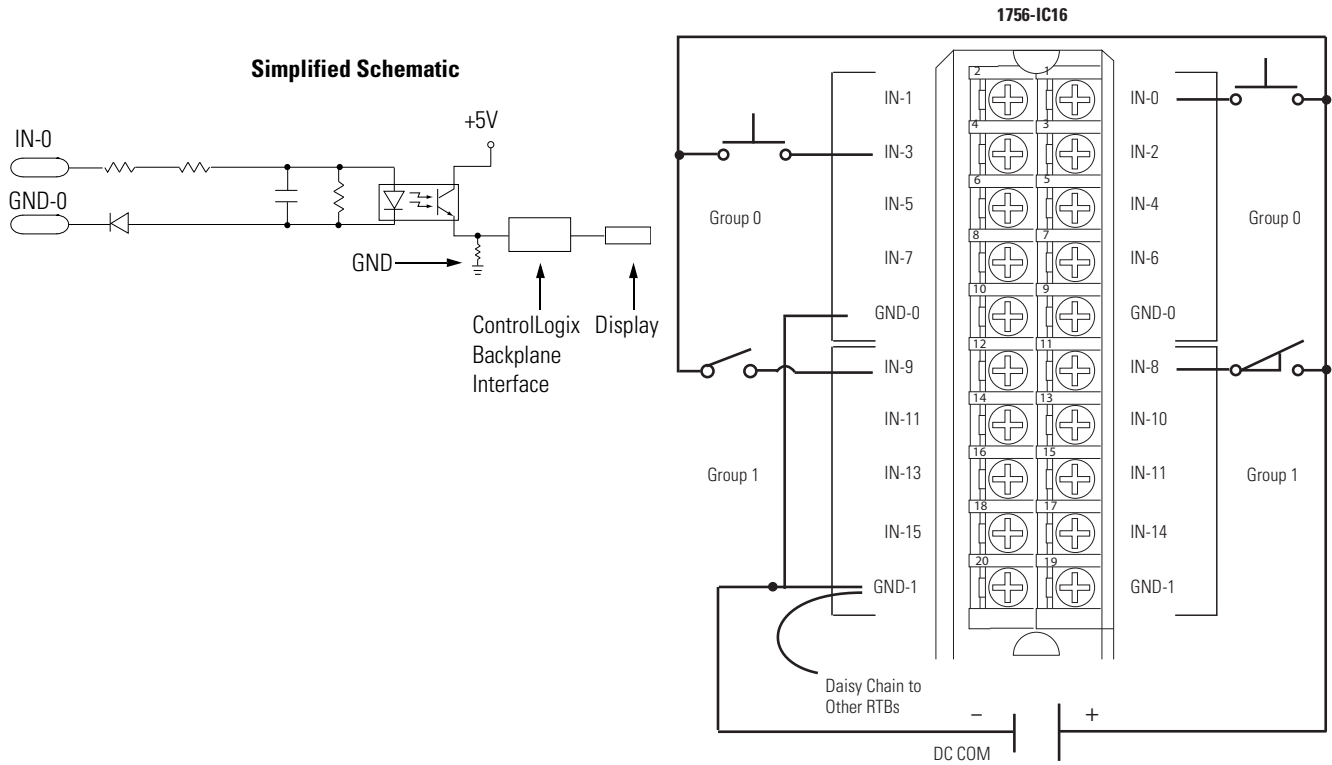

Technical Specifications - 1756-IC16

Attribute	1756-IC16
Inputs	16 (8 points/group)
Voltage category	48V DC sink
Operating voltage range	30...55V DC @ 60 °C (140 °F) 30...60V DC @ 55 °C (131 °F)
Input voltage, nom	48V DC
Input delay time OFF to ON	Hardware delay: 1 ms max + filter time User-selectable filter time: 0, 1, or 2 ms
ON to OFF	Hardware delay: 4 ms max + filter time User-selectable filter time: 0, 1, 2, 9, or 18 ms
Current draw @ 5.1V	100 mA
Current draw @ 24V	3 mA
Total backplane power	0.58 W
Power dissipation, max	5.2 W @ 60 °C (140 °F)
Thermal dissipation	17.73 BTU/hr
Off-state voltage, max	10V
Off-state current, max	1.5 mA
On-state current, min	2 mA @ 30V DC

Technical Specifications - 1756-IC16

Attribute	1756-IC16
On-state current, max	7 mA @ 60V DC
Inrush current, max	250 mA
Input impedance, max	8.57 k Ω @ 60V DC
Cyclic update time	200 μ s...750 ms
Change of state	Software configurable
Timestamp of inputs	\pm 200 μ s
Isolation voltage	250V (continuous), basic insulation type, inputs-to-backplane 125V (continuous), basic insulation type, input group-to-group No isolation between individual group inputs Routine tested @ 1350V AC for 2 s, inputs-to-backplane Routine tested @ 924V AC for 2 s, input group-to-group
Module keying	Electronic, software configurable
Removable terminal block housing	1756-TBNH 1756-TBSH
RTB keying	User-defined mechanical
Slot width	1
Wire category	1 ⁽¹⁾
North American temperature code	T4
IEC temperature code	T4
Enclosure type	None (open-style)
Reverse polarity protection	Yes

(1) Use this conductor category information for planning conductor routing as described in the system-level installation manual. See the Industrial Automation Wiring and Grounding Guidelines, publication [1770-4.1](#).

Environmental Specifications - 1756-IC16

Attribute	1756-IC16
Temperature, operating IEC 60068-2-1 (Test Ad, Operating Cold), IEC 60068-2-2 (Test Bd, Operating Dry Heat), IEC 60068-2-14 (Test Nb, Operating Thermal Shock)	0...60 °C (32...140 °F)
Temperature, surrounding air, max	60 °C (140 °F)
Temperature, storage IEC 60068-2-1 (Test Ab, Unpackaged Nonoperating Cold), IEC 60068-2-2 (Test Bb, Unpackaged Nonoperating Dry Heat), IEC 60068-2-14 (Test Na, Unpackaged Nonoperating Thermal Shock)	-40...85 °C (-40...185 °F)
Relative humidity IEC 60068-2-30 (Test Db, Unpackaged Nonoperating Damp Heat)	5...95% noncondensing
Vibration IEC 60068-2-6 (Test Fc, Operating)	2 g @ 10...500 Hz
Shock, operating IEC 60068-2-27 (Test Ea, Unpackaged Shock)	30 g
Shock, nonoperating IEC 60068-2-27 (Test Ea, Unpackaged Shock)	50 g
Emissions	CISPR 11: Group 1, Class A
ESD immunity IEC 61000-4-2	6 kV contact discharges 8 kV air discharges

Environmental Specifications - 1756-IC16

Attribute	1756-IC16
Radiated RF immunity IEC 61000-4-3	10V/m with 1 kHz sine-wave 80% AM from 80... 2000 MHz 10V/m with 200 Hz 50% Pulse 100% AM @ 900 MHz 10V/m with 200 Hz 50% Pulse 100% AM @ 1890 MHz 3V/m with 1 kHz sine-wave 80% AM from 2000...2700 MHz
EFT/B immunity IEC 61000-4-4	±4 kV at 5 kHz on signal ports
Surge transient immunity IEC 61000-4-5	±1 kV line-line (DM) and ± 2kV line-earth (CM) on signal ports
Conducted RF immunity IEC 61000-4-6	10V rms with 1 kHz sine-wave 80% AM from 150 kHz...80 MHz
Oscillatory surge withstand IEEE C37.90.1	3 kV

Certifications - 1756-IC16

Certification ⁽¹⁾	1756-IC16
UL	UL Listed Industrial Control Equipment, certified for US and Canada. See UL File E65584.
CSA	CSA Certified Process Control Equipment. See CSA File LR54689C. CSA Certified Process Control Equipment for Class I, Division 2 Group A,B,C,D Hazardous Locations. See CSA File LR69960C.
CE	European Union 2004/108/IEC EMC Directive, compliant with: <ul style="list-style-type: none"> • EN 61326-1; Meas./Control/Lab., Industrial Requirements • EN 61000-6-2; Industrial Immunity • EN 61000-6-4; Industrial Emissions • EN 61131-2; Programmable Controllers (Clause 8, Zone A & B) European Union 2006/95/EC LVD, compliant with: <ul style="list-style-type: none"> • EN 61131-2; Programmable Controllers (Clause 11)
C-Tick	Australian Radiocommunications Act, compliant with: AS/NZS CISPR 11; Industrial Emissions
Ex	European Union 94/9/EC ATEX Directive, compliant with: <ul style="list-style-type: none"> • EN 60079-15; Potentially Explosive Atmospheres, Protection "n" • EN 60079-0; General Requirements II 3 G Ex nA IIC T4 X
FM	FM Approved Equipment for use in Class I Division 2 Group A,B,C,D Hazardous Locations

(1) When marked. See the Product Certification link at <http://www.ab.com> for Declarations of Conformity, Certificates, and other certification details.

1756-IF6CIS

ControlLogix sourcing current loop analog input module

1756-IF6CIS 2-wire Transmitter Connected to the Module and the Module Providing 24V DC Loop Power

1756-IF6CIS 2-wire Transmitter Connected to the Module and an External, User-provided Power Supply Providing 24V DC Loop Power

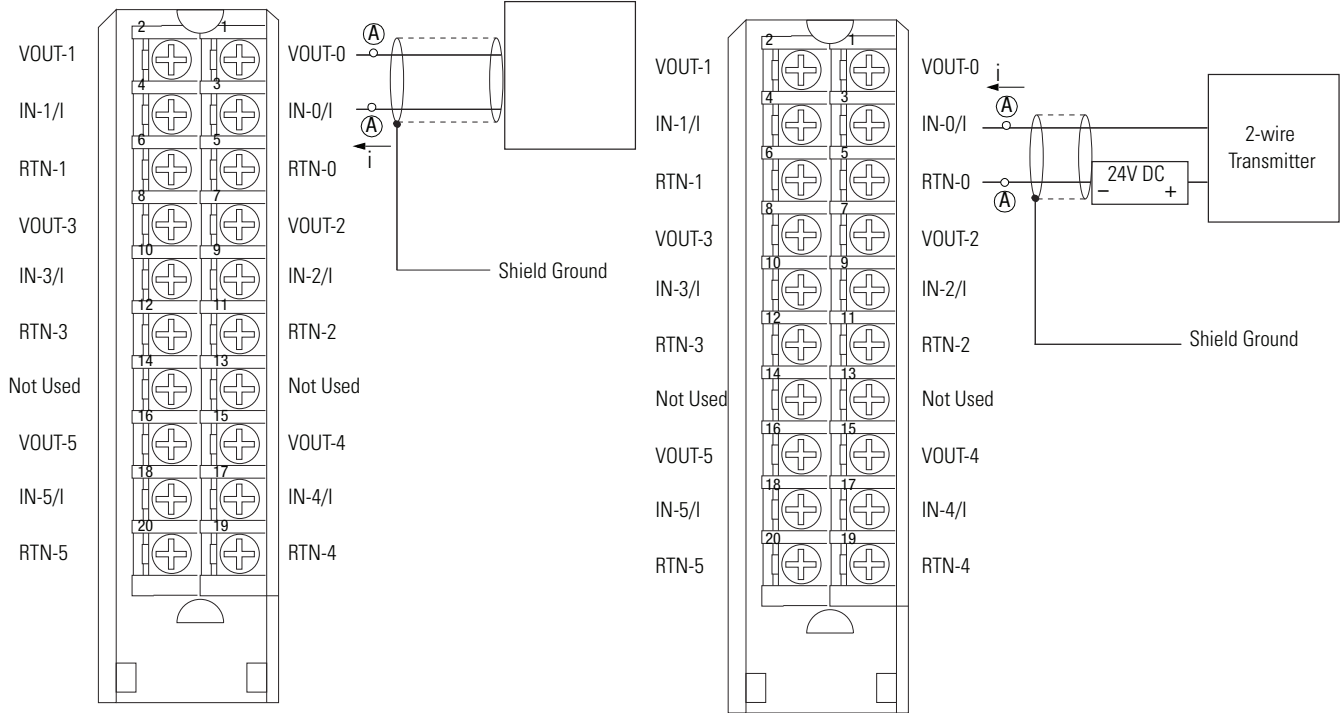

Place additional loop devices (such as strip chart recorders) at either A location in the current loop.

1756-IF6CIS 4-wire Transmitter Connected to the Module and an External, User-provided Power Supply Providing 24V DC Loop Power

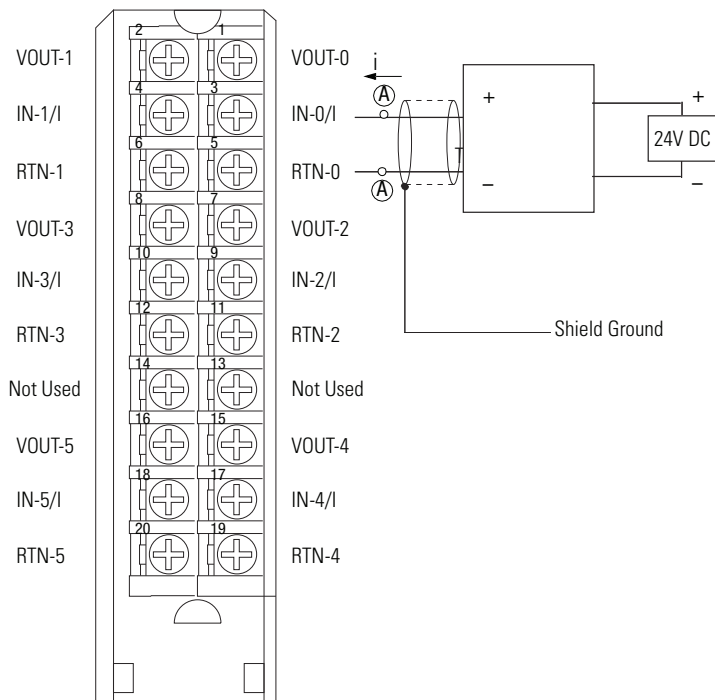

- Place additional loop devices (such as strip chart recorders) at either A location in the current loop.
- User-supplied power supply must not exceed 150VA.

Signal and User Counts - 1756-IF6CIS

Range	Low Signal and User Counts	High Signal and User Counts
0...20 mA	0 mA -32768 counts	21.09376 mA 32767 counts

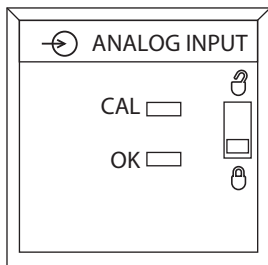

Technical Specifications - 1756-IF6CIS

Attribute	1756-IF6CIS
Inputs	6 individually isolated current sourcing
Input range	0...21 mA (over-range indication when exceeded)
Resolution	16 bits 0.34 μ A/bit
Current draw @ 5.1V	250 mA
Current draw @ 24V	275 mA
Total backplane power	7.9 W
Power dissipation, max	5.1 W @ 60 °C (140 °F)
Thermal dissipation	17.4 BTU/hr
Input impedance	215 Ω , approx
Sourcing voltage, min	20V DC
Sourcing voltage, max	30V DC
Sourcing current, max	Current limited to < 30 mA
Open circuit detection time	Zero reading within 5 s

Technical Specifications - 1756-IF6CIS

Attribute	1756-IF6CIS
Overvoltage protection, max	30V AC/DC with PTC and sense resistor
Normal mode noise rejection	60 dB @ 60 Hz ⁽¹⁾
Common mode noise rejection	120 dB @ 60 Hz 100 dB @ 50 Hz
Channel bandwidth	3...262 Hz (-3 dB) ⁽¹⁾
Settling time	<80 ms to 5% of full scale ⁽¹⁾
Calibrated accuracy 25 °C (77 °F), nom	Better than 0.1% of range
Calibrated accuracy 25 °C (77 °F), max	0.025% of range
Calibration interval	12 months
Offset drift	200 nA/°C
Gain drift with temperature, nom	17 ppm/°C 0.36 µA/°C
Gain drift with temperature, max	35 ppm/°C max 0.74 µA/°C max
Module error	0.2% of range
Module input scan time, min	25 ms min – floating point 10 ms min – integer
On-board data alarming	Yes
Scaling to engineering units	Yes
Real-time channel sampling	Yes
Data format	Integer mode (left justified, 2s complement) IEEE 32-bit floating point
Module conversion method	Sigma-Delta
Isolation voltage	250V (continuous), basic insulation type, input channels-to-backplane, and input channel-to-channel Routine tested at 1350V AC for 2 s
Module keying	Electronic, software configurable
Removable terminal block	1756-TBNH 1756-TBSH
RTB keying	User-defined mechanical
Slot width	1
Wire category	2 ⁽²⁾
North American temperature code	T4A
IEC temperature code	T4
Enclosure type	None (open-style)

(1) Notch filter dependent.

(2) Use this conductor category information for planning conductor routing as described in the system-level installation manual. See the Industrial Automation Wiring and Grounding Guidelines, publication [1770-4.1](#).

Environmental Specifications - 1756-IF6CIS

Attribute	1756-IF6CIS
Temperature, operating IEC 60068-2-1 (Test Ad, Operating Cold), IEC 60068-2-2 (Test Bd, Operating Dry Heat), IEC 60068-2-14 (Test Nb, Operating Thermal Shock)	0...60 °C (32...140 °F)
Temperature, surrounding air, max	60 °C (140 °F)
Temperature, storage IEC 60068-2-1 (Test Ab, Unpackaged Nonoperating Cold), IEC 60068-2-2 (Test Bb, Unpackaged Nonoperating Dry Heat), IEC 60068-2-14 (Test Na, Unpackaged Nonoperating Thermal Shock)	-40...85 °C (-40...185 °F)
Relative humidity IEC 60068-2-30 (Test Db, Unpackaged Nonoperating Damp Heat)	5...95% noncondensing
Vibration IEC 60068-2-6 (Test Fc, Operating)	2 g @ 10...500 Hz
Shock, operating IEC 60068-2-27 (Test Ea, Unpackaged Shock)	30 g
Shock, nonoperating IEC 60068-2-27 (Test Ea, Unpackaged Shock)	50 g
Emissions	CISPR 11: Group 1, Class A
ESD immunity IEC 61000-4-2	6 kV contact discharges 8 kV air discharges
Radiated RF immunity IEC 61000-4-3	10V/m with 1 kHz sine-wave 80% AM from 80...2000 MHz 10V/m with 200 Hz 50% Pulse 100% AM @ 900 MHz 10V/m with 200 Hz 50% Pulse 100% AM @ 1890 MHz 3V/m with 1 kHz sine-wave 80% AM from 2000...2700 MHz
EFT/B immunity IEC 61000-4-4	±2 kV at 5 kHz on shielded signal ports
Surge transient immunity IEC 61000-4-5	±2 kV line-earth (CM) on shielded signal ports
Conducted RF immunity IEC 61000-4-6	10V rms with 1 kHz sine-wave 80% AM from 150 kHz...80 MHz on shielded signal ports

Certifications - 1756-IF6CIS

Certification⁽¹⁾	1756-IF6CIS
UL	UL Listed Industrial Control Equipment, certified for US and Canada. See UL File E65584.
CSA	CSA Certified Process Control Equipment. See CSA File LR54689C. CSA Certified Process Control Equipment for Class I, Division 2 Group A,B,C,D Hazardous Locations. See CSA File LR69960C.
CE	European Union 2004/108/IEC EMC Directive, compliant with: <ul style="list-style-type: none"> • EN 61326-1; Meas./Control/Lab., Industrial Requirements • EN 61000-6-2; Industrial Immunity • EN 61000-6-4; Industrial Emissions • EN 61131-2; Programmable Controllers (Clause 8, Zone A & B) European Union 2006/95/EC LVD, compliant with: <ul style="list-style-type: none"> • EN 61131-2; Programmable Controllers (Clause 11)
C-Tick	Australian Radiocommunications Act, compliant with: AS/NZS CISPR 11; Industrial Emissions
Ex	European Union 94/9/EC ATEX Directive, compliant with: <ul style="list-style-type: none"> • EN 60079-15; Potentially Explosive Atmospheres, Protection "n" • EN 60079-0; General Requirements II 3 G Ex nA IIC T4 X
FM	FM Approved Equipment for use in Class I Division 2 Group A,B,C,D Hazardous Locations
TÜV	TÜV Certified for Functional Safety ⁽²⁾ : Capable of SIL 2

(1) When marked. See the Product Certification link at <http://www.ab.com> for Declarations of Conformity, Certificates, and other certification details.

(2) When used with specified firmware revisions and in accordance with application guidelines described in Using ControlLogix in SIL2 Applications Safety Reference Manual, publication [1756-RM001](#).

1756-IF6I

ControlLogix isolated voltage/current analog input module

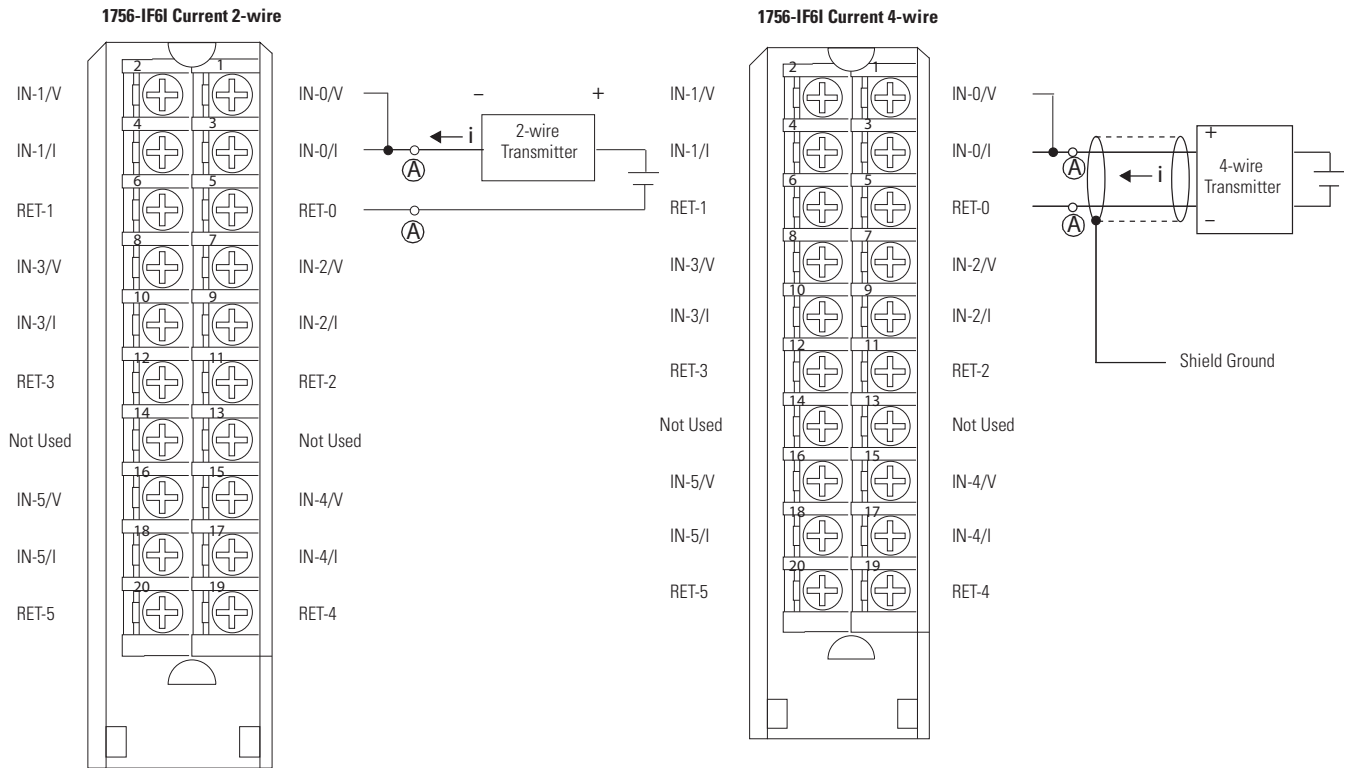

Place additional loop devices (such as strip chart recorders) at either A location.

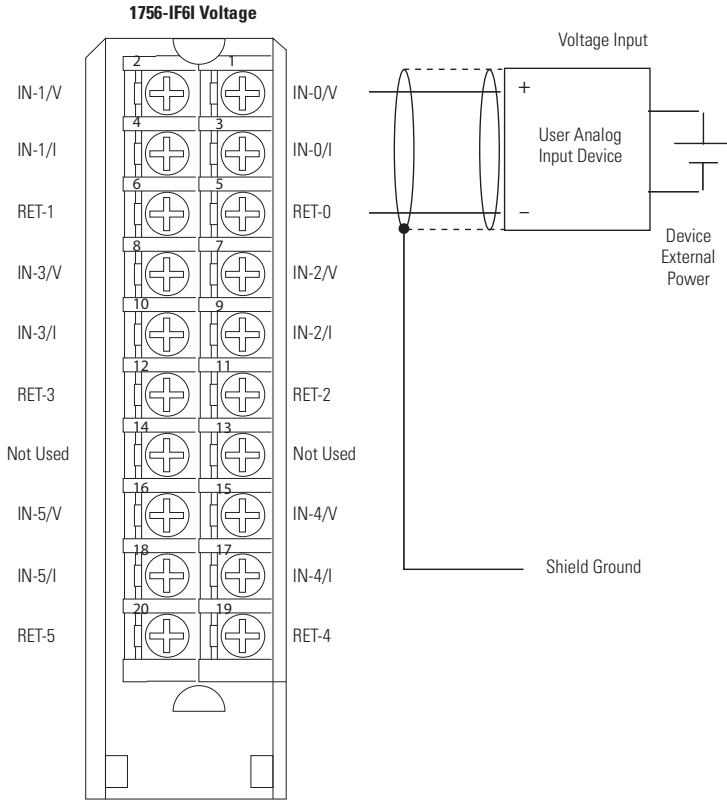

Signal and User Counts - 1756-IF6I

Range	Low Signal and User Counts	High Signal and User Counts
±10V	-10.54688V -32768 counts	10.54688V 32767 counts
0...10V	0V -32768 counts	10.54688V 32767 counts
0...5V	0V -32768 counts	5.27344V 32767 counts
0...20 mA	0 mA -32768 counts	21.09376V 32767 counts

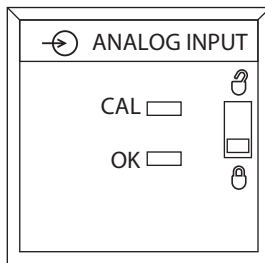

Technical Specifications - 1756-IF6I

Attribute	1756-IF6I
Inputs	6 individually isolated
Input range	±10.5V 0...10.5V 0...5.25V 0...21 mA (over-range indication when exceeded)
Resolution	16 bits 10.5V: 343 μV/bit 0...10.5V: 171 μV/bit 0...5.25V: 86 μV/bit 0...21 mA: 0.34 μA/bit
Current draw @ 5.1V	250 mA
Current draw @ 24V	100 mA
Total backplane power	3.7 W

Technical Specifications - 1756-IF6I

Attribute	1756-IF6I
Power dissipation, max	Voltage: 3.7 W Current: 4.3 W
Thermal dissipation	Voltage: 12.62 BTU/hr Current: 14.32 BTU/hr
Input impedance	Voltage: > 10 M Ω Current: 249 Ω
Open circuit detection time	Positive full scale reading within 5 s
Overvoltage protection, max	Voltage: 120V AC/DC Current: 8V AC/DC (with on-board current resistor)
Normal mode noise rejection	60 dB @ 60 Hz ⁽¹⁾
Common mode noise rejection	120 dB @ 60 Hz 100 dB @ 50 Hz
Channel bandwidth	15 Hz (-3 dB) ⁽¹⁾
Settling time	<80 ms to 5% of full scale ⁽¹⁾
Calibrated accuracy 25 °C (77 °F)	Better than 0.1% of range
Calibration interval	6 months
Offset drift	2 μ V/°C
Gain drift with temperature	Voltage: 35 ppm/°C, 80 ppm/°C max Current: 45 ppm/°C, 90 ppm/°C max
Module error	0.54% of range
Module input scan time, min	25 ms min – floating point 10 ms min – integer ⁽¹⁾
On-board data alarming	Yes
Scaling to engineering units	Yes
Real-time channel sampling	Yes
Data format	Integer mode (left justified, 2s complement) IEEE 32-bit floating point
Module conversion method	Sigma-Delta
Isolation voltage	250V (continuous), basic insulation type, input channels-to-backplane, and input channel-to-channel Routine tested at 1350V AC for 2 s
Module keying	Electronic, software configurable
Removable terminal block	1756-TBNH 1756-TBSH
RTB keying	User-defined mechanical
Slot width	1
Wire category	2 ⁽²⁾
North American temperature code	T4A
IEC temperature code	T4
Enclosure type	None (open-style)

(1) Notch filter dependent.

(2) Use this conductor category information for planning conductor routing as described in the system-level installation manual. See the Industrial Automation Wiring and Grounding Guidelines, publication [1770-4.1](#).

Environmental Specifications - 1756-IF6I

Attribute	1756-IF6I
Temperature, operating IEC 60068-2-1 (Test Ad, Operating Cold), IEC 60068-2-2 (Test Bd, Operating Dry Heat), IEC 60068-2-14 (Test Nb, Operating Thermal Shock)	0...60 °C (32...140 °F)
Temperature, surrounding air, max	60 °C (140 °F)
Temperature, storage IEC 60068-2-1 (Test Ab, Unpackaged Nonoperating Cold), IEC 60068-2-2 (Test Bb, Unpackaged Nonoperating Dry Heat), IEC 60068-2-14 (Test Na, Unpackaged Nonoperating Thermal Shock)	-40...85 °C (-40...185 °F)
Relative humidity IEC 60068-2-30 (Test Db, Unpackaged Nonoperating Damp Heat)	5...95% noncondensing
Vibration IEC 60068-2-6 (Test Fc, Operating)	2 g @ 10...500 Hz
Shock, operating IEC 60068-2-27 (Test Ea, Unpackaged Shock)	30 g
Shock, nonoperating IEC 60068-2-27 (Test Ea, Unpackaged Shock)	50 g
Emissions	CISPR 11: Group 1, Class A
ESD immunity IEC 61000-4-2	6 kV contact discharges 8 kV air discharges
Radiated RF immunity IEC 61000-4-3	10V/m with 1 kHz sine-wave 80% AM from 80...2000 MHz 10V/m with 200 Hz 50% Pulse 100% AM @ 900 MHz 10V/m with 200 Hz 50% Pulse 100% AM @ 1890 MHz 3V/m with 1 kHz sine-wave 80% AM from 2000...2700 MHz
EFT/B immunity IEC 61000-4-4	±2 kV at 5 kHz on shielded signal ports
Surge transient immunity IEC 61000-4-5	±2 kV line-earth (CM) on shielded signal ports
Conducted RF immunity IEC 61000-4-6	10V rms with 1 kHz sine-wave 80% AM from 150 kHz...80 MHz on shielded signal ports

Certifications - 1756-IF6I

Certification⁽¹⁾	1756-IF6I
UL	UL Listed Industrial Control Equipment, certified for US and Canada. See UL File E65584.
CSA	CSA Certified Process Control Equipment. See CSA File LR54689C. CSA Certified Process Control Equipment for Class I, Division 2 Group A,B,C,D Hazardous Locations. See CSA File LR69960C.
CE	European Union 2004/108/IEC EMC Directive, compliant with: <ul style="list-style-type: none"> • EN 61326-1; Meas./Control/Lab., Industrial Requirements • EN 61000-6-2; Industrial Immunity • EN 61000-6-4; Industrial Emissions • EN 61131-2; Programmable Controllers (Clause 8, Zone A & B) European Union 2006/95/EC LVD, compliant with: <ul style="list-style-type: none"> • EN 61131-2; Programmable Controllers (Clause 11)
C-Tick	Australian Radiocommunications Act, compliant with: AS/NZS CISPR 11; Industrial Emissions
Ex	European Union 94/9/EC ATEX Directive, compliant with: <ul style="list-style-type: none"> • EN 60079-15; Potentially Explosive Atmospheres, Protection "n" • EN 60079-0; General Requirements II 3 G Ex nA IIC T4 X
FM	FM Approved Equipment for use in Class I Division 2 Group A,B,C,D Hazardous Locations
TÜV	TÜV Certified for Functional Safety ⁽²⁾ : Capable of SIL 2

(1) When marked. See the Product Certification link at <http://www.ab.com> for Declarations of Conformity, Certificates, and other certification details.

(2) When used with specified firmware revisions and in accordance with application guidelines described in Using ControlLogix in SIL2 Applications Safety Reference Manual, publication [1756-RM001](#).

1756-IF8

ControlLogix voltage/current analog input module

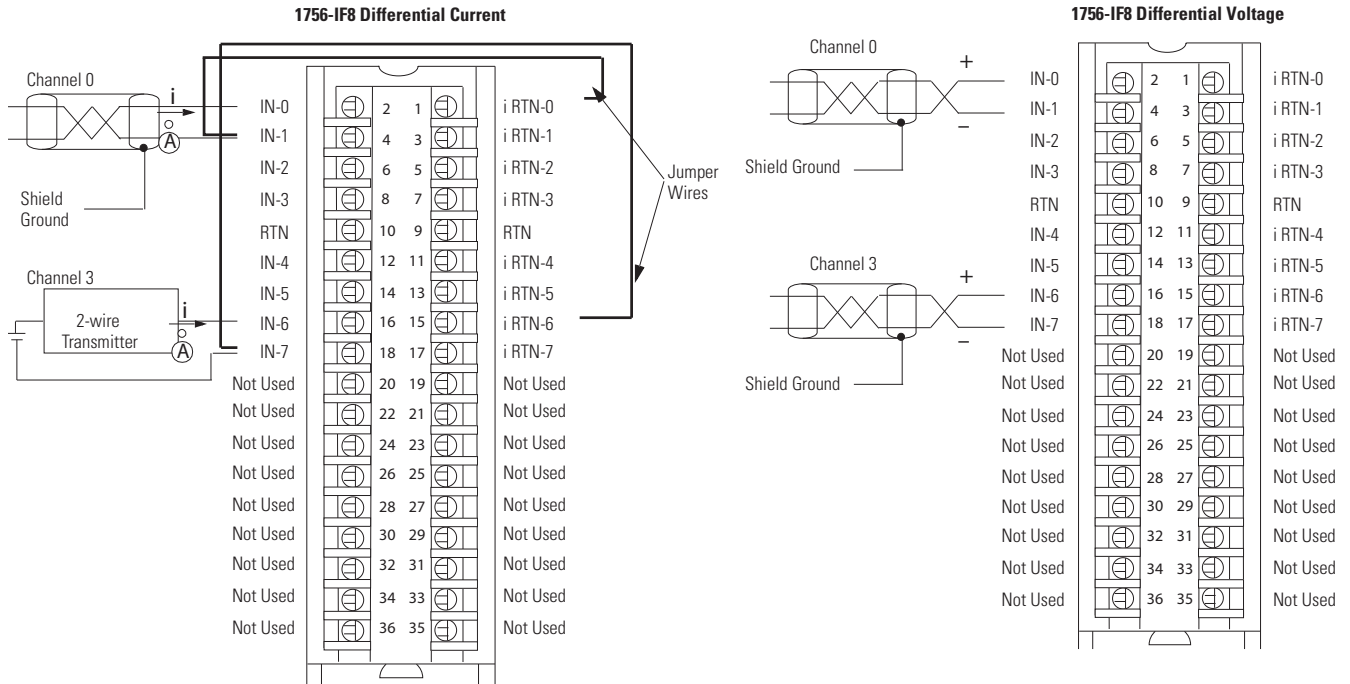

- Use this table when wiring your module in Differential mode.

This channel	Uses these terminals
Channel 0	IN-0 (+), IN-1 (-), i RTN-0
Channel 1	IN-2 (+), IN-3 (-), i RTN-2
Channel 2	IN-4 (+), IN-5 (-), i RTN-4
Channel 3	IN-6 (+), IN-7 (-), i RTN-6

- All terminals marked RTN are connected internally.
- A 249 Ω current loop resistor is located between IN-x and i RTN-x terminals.
- If multiple (+) or multiple (-) terminals are tied together, connect that tie point to a RTN terminal to maintain the module's accuracy.
- Place additional loop devices (such as strip chart recorders) at the A location in the current loop.

IMPORTANT: When operating in 2 channel, High Speed mode, only use channels 0 and 2.

- Use this table when wiring your module in Differential mode.

This channel	Uses these terminals
Channel 0	IN-0 (+), IN-1 (-)
Channel 1	IN-2 (+), IN-3 (-)
Channel 2	IN-4 (+), IN-5 (-)
Channel 3	IN-6 (+), IN-7 (-)

- All terminals marked RTN are connected internally.
- If multiple (+) or multiple (-) terminals are tied together, connect that tie point to a RTN terminal to maintain the module's accuracy.
- Terminals marked RTN or i RTN are not used for differential voltage wiring.

IMPORTANT: When operating in 2 channel, High Speed mode, only use channels 0 and 2.

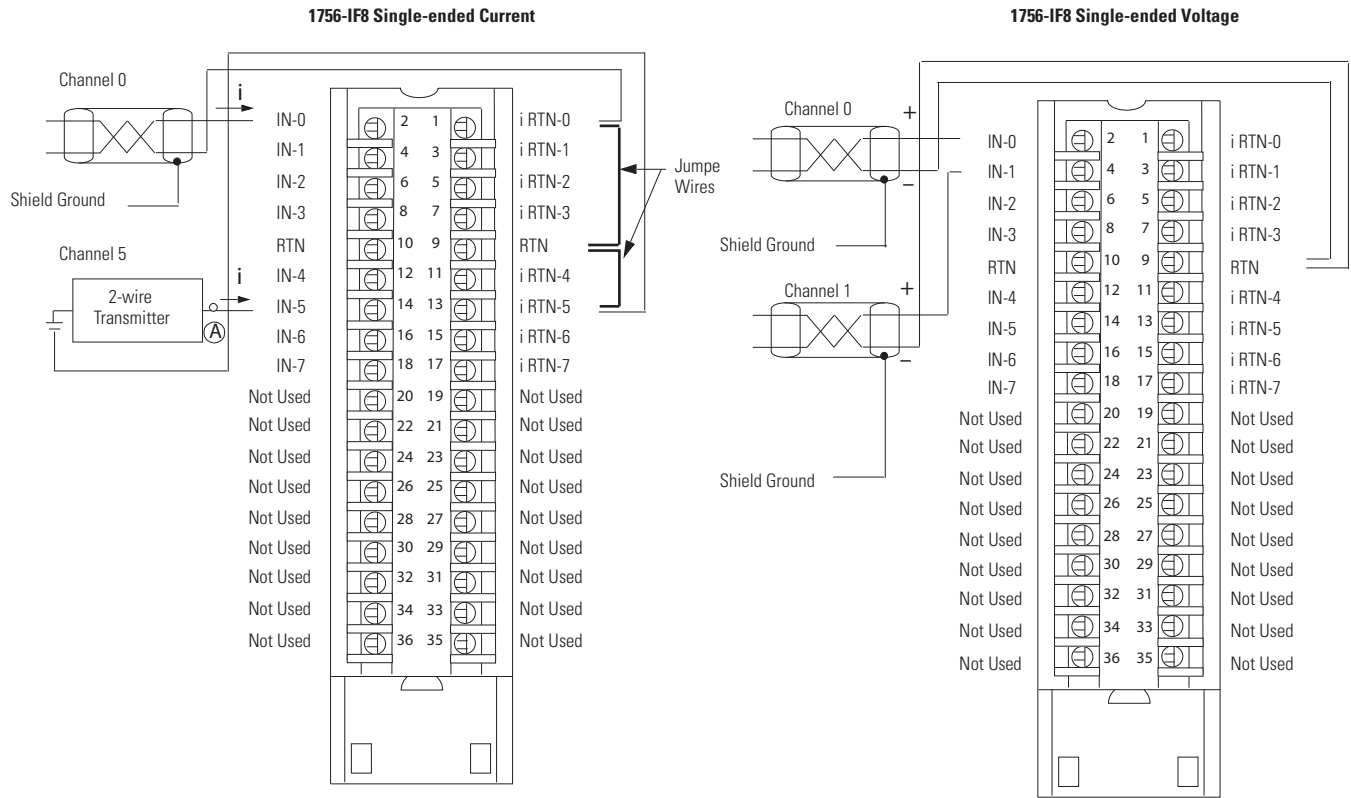

- All terminals marked RTN are connected internally.
- For current applications, all terminals marked iRTN must be wired to terminals marked RTN.
- A 249 Ω current loop resistor is located between IN-x and iRTN-x terminals.
- Place additional loop devices (such as strip chart recorders) at the A location in the current loop.

- All terminals marked RTN are connected internally.
- Terminals marked iRTN are not used for single-ended voltage wiring.

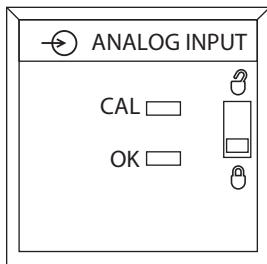

Technical Specifications - 1756-IF8

Attribute	1756-IF8
Inputs	8 single-ended 4 differential 2 high-speed differential
Input range	±10.25V 0...10.25V 0...5.125V 0...20.5 mA
Resolution	±10.25V: 320 μV/count (15 bits plus sign bipolar) 0...10.25V: 160 μV/count (16 bits) 0...5.125V: 80 μV/count (16 bits) 0...20.5mA: 0.32 μA/count (16 bits)
Current draw @ 5.1V	150 mA
Current draw @ 24V	40 mA
Total backplane power	1.73 W
Power dissipation, max	Voltage: 1.73 W Current: 2.33 W

Technical Specifications - 1756-IF8

Attribute	1756-IF8
Thermal dissipation	Voltage: 5.88 BTU/hr Current: 7.92 BTU/hr
Input impedance	Voltage: >1 M Ω Current: 249 Ω
Open circuit detection time	Differential voltage: Positive full scale reading within 5 s Single-ended/diff. current: Negative full scale reading within 5 s Single-ended voltage: Even numbered channels go to positive full scale reading within 5 s, odd numbered channels go to negative full scale reading within 5 s
Overvoltage protection, max	Voltage: 30V DC Current: 8V DC
Normal mode noise rejection	>80 dB @ 50/60 Hz ⁽¹⁾
Common mode noise rejection	>100 dB @ 50/60 Hz
Calibrated accuracy 25 °C (77 °F)	Voltage: Better than 0.05% of range Current: Better than 0.15% of range
Calibration interval	12 months
Offset drift	45 μ V/°C
Gain drift with temperature	Voltage: 15 ppm/°C Current: 20 ppm/°C
Module error	Voltage: 0.1% of range Current: 0.3% of range
Module input scan time, min	8 pt single-ended (floating point): 16...488 ms 4 pt differential (floating point): 8...244 ms 2 pt differential (floating point): 5...122 m ⁽¹⁾
On-board data alarming	Yes
Scaling to engineering units	Yes
Real-time channel sampling	Yes
Data format	Integer mode (left justified, 2s complement) IEEE 32-bit floating point
Module conversion method	Sigma-Delta
Isolation voltage	250V (continuous), reinforced insulation type, inputs-to-backplane. No isolation between individual inputs Routine tested at 1350V AC for 2 s
Module keying	Electronic, software configurable
Removable terminal block	1756-TBCH 1756-TBS6H
RTB keying	User-defined mechanical
Slot width	1
Wire category	2 ⁽²⁾
North American temperature code	T4A
IEC temperature code	T4
Enclosure type	None (open-style)

(1) Notch filter dependent.

(2) Use this conductor category information for planning conductor routing as described in the system-level installation manual. See the Industrial Automation Wiring and Grounding Guidelines, publication [1770-4.1](#).

Environmental Specifications - 1756-IF8

Attribute	1756-IF8
Temperature, operating IEC 60068-2-1 (Test Ad, Operating Cold), IEC 60068-2-2 (Test Bd, Operating Dry Heat), IEC 60068-2-14 (Test Nb, Operating Thermal Shock)	0...60 °C (32...140 °F)
Temperature, surrounding air, max	60 °C (140 °F)
Temperature, storage IEC 60068-2-1 (Test Ab, Unpackaged Nonoperating Cold), IEC 60068-2-2 (Test Bb, Unpackaged Nonoperating Dry Heat), IEC 60068-2-14 (Test Na, Unpackaged Nonoperating Thermal Shock)	-40...85 °C (-40...185 °F)
Relative humidity IEC 60068-2-30 (Test Db, Unpackaged Nonoperating Damp Heat)	5...95% noncondensing
Vibration IEC 60068-2-6 (Test Fc, Operating)	2 g @ 10...500 Hz
Shock, operating IEC 60068-2-27 (Test Ea, Unpackaged Shock)	30 g
Shock, nonoperating IEC 60068-2-27 (Test Ea, Unpackaged Shock)	50 g
Emissions	CISPR 11: Group 1, Class A
ESD immunity IEC 61000-4-2	6 kV contact discharges 8 kV air discharges
Radiated RF immunity IEC 61000-4-3	10V/m with 1 kHz sine-wave 80% AM from 80...2000 MHz 10V/m with 200 Hz 50% Pulse 100% AM @ 900 MHz 10V/m with 200 Hz 50% Pulse 100% AM @ 1890 MHz 3V/m with 1 kHz sine-wave 80% AM from 2000...2700 MHz
EFT/B immunity IEC 61000-4-4	±2 kV at 5 kHz on shielded signal ports
Surge transient immunity IEC 61000-4-5	±2 kV line-earth (CM) on shielded signal ports
Conducted RF immunity IEC 61000-4-6	10V rms with 1 kHz sine-wave 80% AM from 150 kHz...80 MHz on shielded signal ports

Certifications - 1756-IF8

Certification⁽¹⁾	1756-IF8
UL	UL Listed Industrial Control Equipment, certified for US and Canada. See UL File E65584.
CSA	CSA Certified Process Control Equipment. See CSA File LR54689C. CSA Certified Process Control Equipment for Class I, Division 2 Group A,B,C,D Hazardous Locations. See CSA File LR69960C.
CE	European Union 2004/108/IEC EMC Directive, compliant with: <ul style="list-style-type: none"> • EN 61326-1; Meas./Control/Lab., Industrial Requirements • EN 61000-6-2; Industrial Immunity • EN 61000-6-4; Industrial Emissions • EN 61131-2; Programmable Controllers (Clause 8, Zone A & B) European Union 2006/95/EC LVD, compliant with: <ul style="list-style-type: none"> • EN 61131-2; Programmable Controllers (Clause 11)
C-Tick	Australian Radiocommunications Act, compliant with: AS/NZS CISPR 11; Industrial Emissions
Ex	European Union 94/9/EC ATEX Directive, compliant with: <ul style="list-style-type: none"> • EN 60079-15; Potentially Explosive Atmospheres, Protection "n" • EN 60079-0; General Requirements II 3 G Ex nA IIC T4 X
FM	FM Approved Equipment for use in Class I Division 2 Group A,B,C,D Hazardous Locations
TÜV	TÜV Certified for Functional Safety ⁽²⁾ : Capable of SIL 2

(1) When marked. See the Product Certification link at <http://www.ab.com> for Declarations of Conformity, Certificates, and other certification details.

(2) When used with specified firmware revisions and in accordance with application guidelines described in Using ControlLogix in SIL2 Applications Safety Reference Manual, publication [1756-RM001](#).

1756-IF8H

ControlLogix voltage/current analog input module with HART protocol

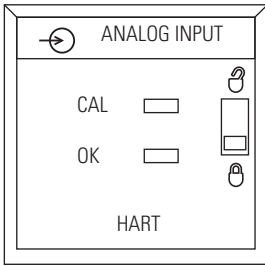
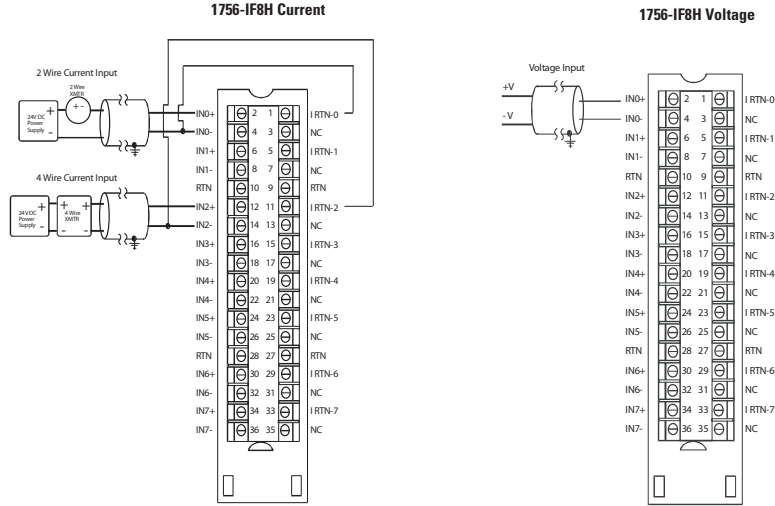

Technical Specifications - 1756-IF8H

Attribute	1756-IF8H
Inputs	8 differential voltage or current
Input range	±10V 0...5V 1...5V 0...10V 0...20 mA 4...20 mA
Resolution	16...21 bits
Current draw @ 5V	300 mA
Current draw @ 24V	135 mA
Total backplane power	4.77 W
Power dissipation, max	Voltage: 3.21 W Current: 4.01 W
Thermal dissipation	Voltage: 11.0 BTU/hr Current: 13.7 BTU/hr
Input impedance	> 1 MΩ voltage 250 Ω current
Open circuit detection time	Positive full scale reading within 5 s
Overvoltage protection, max	Voltage: 30V DC Current: 8V DC
Normal mode noise rejection	> 80 dB @ 50/60 Hz
Common mode noise rejection	> 100 dB @ 50/60 Hz
Calibrated accuracy	Voltage: Better than 0.05% of range Current: Better than 0.15% of range
Calibration interval	12 months
Offset drift	90 μV/°C
Gain drift with temperature	Voltage: 10 ppm/°C Current: 20 ppm/°C

Technical Specifications - 1756-IF8H

Attribute	1756-IF8H
Module error	Voltage: 0.1% of range Current: 0.3% of range
Module input scan time, min	18...488 ms (filter dependent)
Module HART scan time	Typically 1 s per HART channel enabled. Estimate 10 s if all 8 channels have HART enabled Pass through messages, handheld communicators, secondary masters, communication errors, or configuration changes can significantly increase the update time
Data format	Integer mode (left justified, 2s complement) IEEE 32-bit floating point
Input conversion method	Successive approximation
Output conversion method	R-Ladder DAC, monotonicity with no missing codes
Isolation voltage	50V (continuous), basic insulation type, input channels-to-backplane, and input channel-to-channel Type tested at 1500V AC for 60 s
Module keying	Electronic, software configurable
Removable terminal block	1756-TBCH 1756-TBS6H
RTB keying	User-defined mechanical
Slot width	1
Wire category	2 - on signal ports ⁽¹⁾
North American temperature code	T4A
IEC temperature code	T4
Enclosure type	None (open-style)

(1) Use this conductor category information for planning conductor routing as described in the system-level installation manual. See the Industrial Automation Wiring and Grounding Guidelines, publication [1770-4.1](#).

Environmental Specifications - 1756-IF8H

Attribute	1756-IF8H
Temperature, operating IEC 60068-2-1 (Test Ad, Operating Cold), IEC 60068-2-2 (Test Bd, Operating Dry Heat), IEC 60068-2-14 (Test Nb, Operating Thermal Shock)	0...60 °C (32...140 °F)
Temperature, surrounding air, max	60 °C (140 °F)
Temperature, storage IEC 60068-2-1 (Test Ab, Unpackaged Nonoperating Cold), IEC 60068-2-2 (Test Bb, Unpackaged Nonoperating Dry Heat), IEC 60068-2-14 (Test Na, Unpackaged Nonoperating Thermal Shock)	-40...85 °C (-40...185 °F)
Relative humidity IEC 60068-2-30 (Test Db, Unpackaged Nonoperating Damp Heat)	5...95% noncondensing
Vibration IEC 60068-2-6 (Test Fc, Operating)	2 g @ 10...500 Hz
Shock, operating IEC 60068-2-27 (Test Ea, Unpackaged Shock)	30 g
Shock, nonoperating IEC 60068-2-27 (Test Ea, Unpackaged Shock)	50 g
Emissions	CISPR 11: Group 1, Class A
ESD immunity IEC 61000-4-2	6 kV contact discharges 8 kV air discharges

Environmental Specifications - 1756-IF8H

Attribute	1756-IF8H
Radiated RF immunity IEC 61000-4-3	10V/m with 1 kHz sine-wave 80% AM from 80... 2000 MHz 10V/m with 200 Hz 50% Pulse 100% AM @ 900 MHz 10V/m with 200 Hz 50% Pulse 100% AM @ 1890 MHz 1V/m with 1 kHz sine-wave 80% AM from 2000...2700 MHz
EFT/B immunity IEC 61000-4-4	±2 kV at 5 kHz on shielded signal ports
Surge transient immunity IEC 61000-4-5	±2 kV line-earth (CM) on shielded signal ports
Conducted RF immunity IEC 61000-4-6	10V rms with 1 kHz sine-wave 80% AM from 150 kHz...80 MHz on shielded signal ports

Certifications - 1756-IF8H

Certification ⁽¹⁾	1756-IF8H
c-UL-us	UL Listed Industrial Control Equipment, certified for US and Canada. See UL File E65584.
CSA	CSA Certified Process Control Equipment for Class I, Division 2 Group A,B,C,D Hazardous Locations. See CSA File LR101622C.
CE	European Union 2004/108/IEC EMC Directive, compliant with: <ul style="list-style-type: none"> • EN 61326-1; Meas./Control/Lab., Industrial Requirements • EN 61000-6-2; Industrial Immunity • EN 61000-6-4; Industrial Emissions • EN 61131-2; Programmable Controllers (Clause 8, Zone A & B)
C-Tick	Australian Radiocommunications Act, compliant with: AS/NZS CISPR 11; Industrial Emissions
Ex	European Union 94/9/EC ATEX Directive, compliant with: <ul style="list-style-type: none"> • EN 60079-15; Potentially Explosive Atmospheres, Protection "n" • EN 60079-0; General Requirements II 3 G Ex nA IIC T4 X
FM	FM Approved Equipment for use in Class I Division 2 Group A,B,C,D Hazardous Locations
TÜV	TÜV Certified for Functional Safety ⁽²⁾ : Capable of SIL 2

(1) When marked. See the Product Certification link at <http://www.ab.com> for Declarations of Conformity, Certificates, and other certification details.

(2) When used with specified firmware revisions and in accordance with application guidelines described in Using ControlLogix in SIL2 Applications Safety Reference Manual, publication [1756-RM001](#).

1756-IF16

ControlLogix voltage/current analog input module

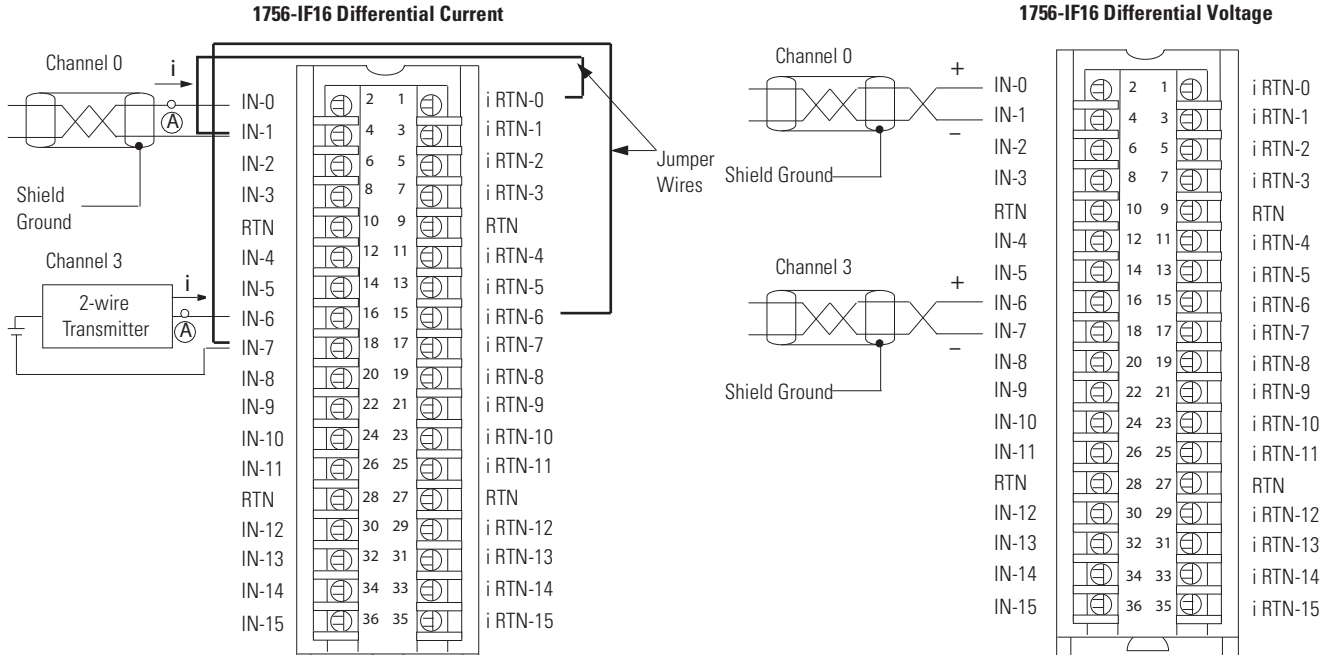

- Use this table when wiring your module in Differential mode.

This channel	Uses these terminals
Channel 0	IN-0 (+), IN-1 (-), i RTN-0
Channel 1	IN-2 (+), IN-3 (-), i RTN-2
Channel 2	IN-4 (+), IN-5 (-), i RTN-4
Channel 3	IN-6 (+), IN-7 (-), i RTN-6
Channel 4	IN-8 (+), IN-9 (-), i RTN-8
Channel 5	IN-10 (+), IN-11 (-), i RTN-10
Channel 6	IN-12 (+), IN-13 (-), i RTN-12
Channel 7	IN-14 (+), IN-15 (-), i RTN-14

- All terminals marked RTN are connected internally.
- A 249 Ω current loop resistor is located between IN-x and i RTN-x terminals.
- If multiple (+) or multiple (-) terminals are tied together, connect that tie point to a RTN terminal to maintain the module's accuracy.
- Place additional loop devices (such as strip chart recorders) at the A location in the current loop.

IMPORTANT: When operating in 4 channel, High Speed mode, only use channels 0, 2, 4, and 6.

- Use this table when wiring your module in Differential mode.

This channel	Uses these terminals
Channel 0	IN-0 (+), IN-1 (-)
Channel 1	IN-2 (+), IN-3 (-)
Channel 2	IN-4 (+), IN-5 (-)
Channel 3	IN-6 (+), IN-7 (-)
Channel 4	IN-8 (+), IN-9 (-)
Channel 5	IN-10 (+), IN-11 (-)
Channel 6	IN-12 (+), IN-13 (-)
Channel 7	IN-14 (+), IN-15 (-)

- All terminals marked RTN are connected internally.
- If multiple (+) or multiple (-) terminals are tied together, connect that tie point to a RTN terminal to maintain the module's accuracy.
- Terminals marked RTN or i RTN are not used for differential voltage wiring.

IMPORTANT: When operating in 4 channel, High Speed mode, only use channels 0, 2, 4, and 6.

1756-IF16 Single-ended Current

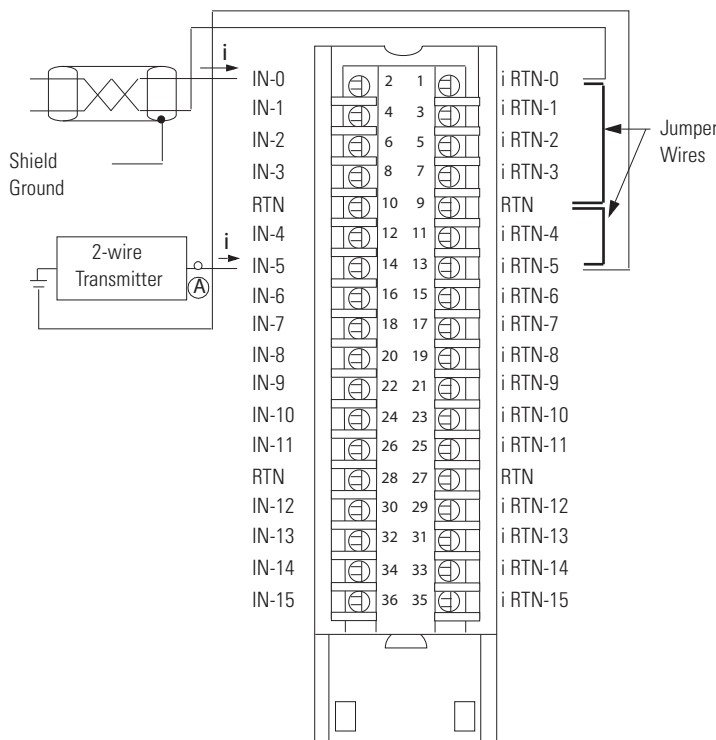

1756-IF16 Single-ended Voltage

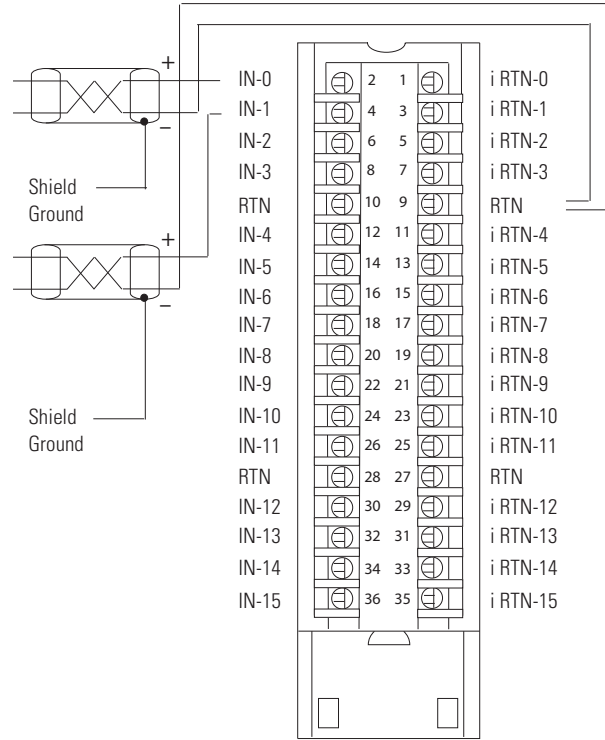

- All terminals marked RTN are connected internally.
- For current applications, all terminals marked i RTN must be wired to terminals marked RTN.
- A 249 Ω current loop resistor is located between IN-x and iRTN-x terminals.
- Place additional loop devices (such as strip chart recorders) at the A location in the current loop.

- All terminals marked RTN are connected internally.
- Terminals marked i RTN are not used for single-ended voltage wiring.

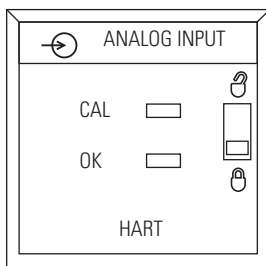

Technical Specifications - 1756-IF16

Attribute	1756-IF16
Inputs	16 single ended, 8 differential or 4 differential (high speed)
Input range	±10.25V 0...10.25V 0...5.125V 0...20.5 mA
Resolution	320 µV/count (15 bits + sign bipolar) @ ±10.25V 160 µV/count (16 bits) @ 0...10.25V 80 µV/count (16 bits) @ 0...5.125V 0.32 µA/count (16 bits) @ 0...20.5 mA
Current draw @ 5.1V	150 mA
Current draw @ 24V	65 mA
Total backplane power	2.33 W
Power dissipation, max	Voltage: 2.3 W Current: 3.9 W

Technical Specifications - 1756-IF16

Attribute	1756-IF16
Thermal dissipation	Voltage: 7.84 BTU/hr Current: 13.3 BTU/hr
Input impedance	Voltage: >10 M Ω Current: 249 Ω
Open circuit detection time	Differential voltage - Positive full scale reading within 5 s Single-ended/differential current - Negative full scale reading within 5 s Single-ended voltage - Even numbered channels go to positive full scale reading within 5 s, odd numbered channels go to negative full scale reading within 5 s
Overvoltage protection, max	Voltage: 30V DC Current: 8V DC
Normal mode noise rejection	>80 dB @ 50/60 Hz ⁽¹⁾
Common mode noise rejection	>100 dB @ 50/60 Hz
Channel bandwidth	15 Hz (-3 dB) ⁽¹⁾
Settling time	<80 ms to 5% of full scale ⁽¹⁾
Calibrated accuracy 25 °C (77 °F)	Voltage: Better than 0.05% of range Current: Better than 0.15% of range
Offset drift	45 μ V/°C
Gain drift with temperature	Voltage: 15 ppm/°C Current: 20 ppm/°C
Module error	Voltage: 0.1% of range Current: 0.3% of range
Module input scan time, min	16 pt single-ended: 16...488 ms 8 pt differential: 8...244 ms 4 pt differential: 5...122 ms ⁽¹⁾
On-board data alarming	Yes
Scaling to engineering units	Yes
Real-time channel sampling	Yes
Data format	Integer mode (left justified, 2s complement) IEEE 32-bit floating point
Module conversion method	Sigma-Delta
Isolation voltage	250V (continuous), reinforced insulation type, inputs-to-backplane No isolation between individual inputs Routine tested at 1350V AC for 2 s
Module keying	Electronic, software configurable
Removable terminal block	1756-TBCH 1756-TBS6H
RTB keying	User-defined mechanical
Slot width	1
Wire category	2 ⁽²⁾
North American temperature code	T4A
IEC temperature code	T4
Enclosure type	None (open-style)

(1) Notch filter dependent.

(2) Use this conductor category information for planning conductor routing as described in the system-level installation manual. See the Industrial Automation Wiring and Grounding Guidelines, publication [1770-4.1](#).

Environmental Specifications - 1756-IF16

Attribute	1756-IF16
Temperature, operating IEC 60068-2-1 (Test Ad, Operating Cold), IEC 60068-2-2 (Test Bd, Operating Dry Heat), IEC 60068-2-14 (Test Nb, Operating Thermal Shock)	0...60 °C (32...140 °F)
Temperature, surrounding air, max	60 °C (140 °F)
Temperature, storage IEC 60068-2-1 (Test Ab, Unpackaged Nonoperating Cold), IEC 60068-2-2 (Test Bb, Unpackaged Nonoperating Dry Heat), IEC 60068-2-14 (Test Na, Unpackaged Nonoperating Thermal Shock)	-40...85 °C (-40...185 °F)
Relative humidity IEC 60068-2-30 (Test Db, Unpackaged Nonoperating Damp Heat)	5...95% noncondensing
Vibration IEC 60068-2-6 (Test Fc, Operating)	2 g @ 10...500 Hz
Shock, operating IEC 60068-2-27 (Test Ea, Unpackaged Shock)	30 g
Shock, nonoperating IEC 60068-2-27 (Test Ea, Unpackaged Shock)	50 g
Emissions	CISPR 11: Group 1, Class A
ESD immunity IEC 61000-4-2	6 kV contact discharges 8 kV air discharges
Radiated RF immunity IEC 61000-4-3	10V/m with 1 kHz sine-wave 80% AM from 80...2000 MHz 10V/m with 200 Hz 50% Pulse 100% AM @ 900 MHz 10V/m with 200 Hz 50% Pulse 100% AM @ 1890 MHz 3V/m with 1 kHz sine-wave 80% AM from 2000...2700 MHz
EFT/B immunity IEC 61000-4-4	±2 kV at 5 kHz on shielded signal ports
Surge transient immunity IEC 61000-4-5	±2 kV line-earth (CM) on shielded signal ports
Conducted RF immunity IEC 61000-4-6	10V rms with 1 kHz sine-wave 80% AM from 150 kHz...80 MHz on shielded signal ports

Certifications - 1756-IF16

Certification⁽¹⁾	1756-IF16
UL	UL Listed Industrial Control Equipment, certified for US and Canada. See UL File E65584.
CSA	CSA Certified Process Control Equipment. See CSA File LR54689C. CSA Certified Process Control Equipment for Class I, Division 2 Group A,B,C,D Hazardous Locations. See CSA File LR69960C.
CE	European Union 2004/108/IEC EMC Directive, compliant with: <ul style="list-style-type: none"> • EN 61326-1; Meas./Control/Lab., Industrial Requirements • EN 61000-6-2; Industrial Immunity • EN 61000-6-4; Industrial Emissions • EN 61131-2; Programmable Controllers (Clause 8, Zone A & B) European Union 2006/95/EC LVD, compliant with: <ul style="list-style-type: none"> • EN 61131-2; Programmable Controllers (Clause 11)
C-Tick	Australian Radiocommunications Act, compliant with: AS/NZS CISPR 11; Industrial Emissions
Ex	European Union 94/9/EC ATEX Directive, compliant with: <ul style="list-style-type: none"> • EN 60079-15; Potentially Explosive Atmospheres, Protection "n" • EN 60079-0; General Requirements II 3 G Ex nA IIC T4 X
FM	FM Approved Equipment for use in Class I Division 2 Group A,B,C,D Hazardous Locations
TÜV	TÜV Certified for Functional Safety ⁽²⁾ : Capable of SIL 2

(1) When marked. See the Product Certification link at <http://www.ab.com> for Declarations of Conformity, Certificates, and other certification details.

(2) When used with specified firmware revisions and in accordance with application guidelines described in Using ControlLogix in SIL2 Applications Safety Reference Manual, publication [1756-RM001](#).

1756-IF16H

ControlLogix current analog input module with HART protocol

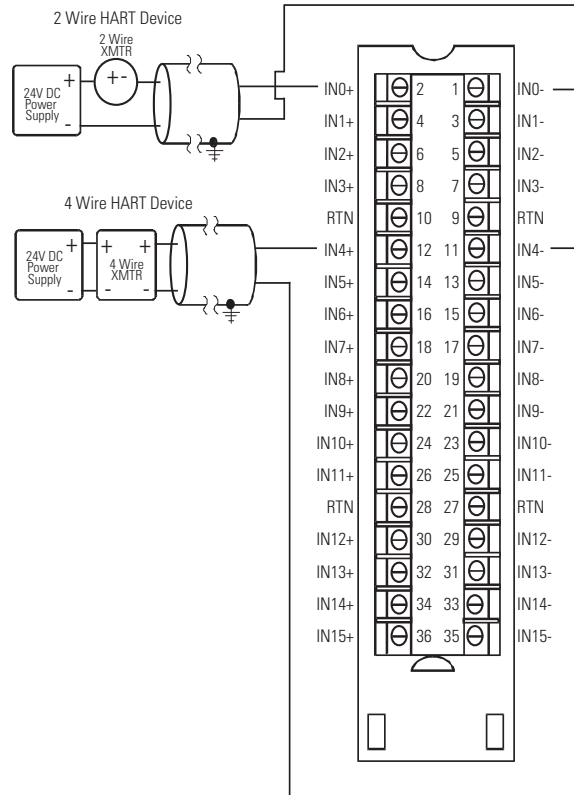

When a common supply is used you should tie the IN- to RTN.

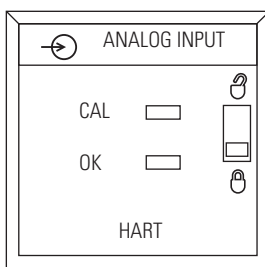

Technical Specifications - 1756-IF16H

Attribute	1756-IF16H
Inputs	16 differential, current
Input range	0...20 mA 4...20 mA
Resolution	16...21 bits
Current draw @ 5V	200 mA
Current draw @ 24V	125 mA
Total backplane power	4.02 W
Power dissipation, max	6 W
Thermal dissipation	12 BTU/hr
Input impedance	249 Ω
Open circuit detection time	Positive full scale reading within 5 s
Overvoltage protection, max	8V DC
Normal mode noise rejection	74 dB @ 50/60 Hz (15 Hz filter) 90 dB @ 60 Hz (20 Hz filter)
Common mode noise rejection	> 90 dB @ 50/60 Hz (15 and 20 Hz filters only)
Repeatability	Better than 0.01% of range (15 and 20 Hz filters only)
Calibrated accuracy	Better than 0.13% of range (all filters)

Technical Specifications - 1756-IF16H

Attribute	1756-IF16H
Calibration interval	12 months
Offset drift	27 $\mu\text{V}/^\circ\text{C}$
Gain drift with temperature	11 ppm/ $^\circ\text{C}$
Module error	0.3% of range
Module input scan time, min	11...328 ms (filter dependent)
Module HART scan time	Typically 1 s Pass through messages, handheld communicators, secondary masters, communication errors, or configuration changes can significantly increase the update time
Data format	Integer mode (left justified, 2s complement) IEEE 32-bit floating point
Input conversion method	Successive approximation
Output conversion method	R-Ladder DAC, monotonicity with no missing codes
Isolation voltage	50V (continuous), basic insulation type, inputs-to-backplane No isolation between individual inputs Type tested at 1500V DC for 60 s
Module keying	Electronic, software configurable
Removable terminal block	1756-TBCH 1756-TBS6H
RTB keying	User-defined mechanical
Slot width	1
Wire category	2 - on signal ports ⁽¹⁾
North American temperature code	T5
IEC temperature code	T4
Enclosure type	None (open-style)

(1) Use this conductor category information for planning conductor routing as described in the system-level installation manual. See the Industrial Automation Wiring and Grounding Guidelines, publication [1770-4.1](#).

Environmental Specifications - 1756-IF16H

Attribute	1756-IF16H
Temperature, operating IEC 60068-2-1 (Test Ad, Operating Cold), IEC 60068-2-2 (Test Bd, Operating Dry Heat), IEC 60068-2-14 (Test Nb, Operating Thermal Shock)	0...60 $^\circ\text{C}$ (32...140 $^\circ\text{F}$)
Temperature, surrounding air, max	60 $^\circ\text{C}$ (140 $^\circ\text{F}$)
Temperature, storage IEC 60068-2-1 (Test Ab, Unpackaged Nonoperating Cold), IEC 60068-2-2 (Test Bb, Unpackaged Nonoperating Dry Heat), IEC 60068-2-14 (Test Na, Unpackaged Nonoperating Thermal Shock)	-40...85 $^\circ\text{C}$ (-40...185 $^\circ\text{F}$)
Relative humidity IEC 60068-2-30 (Test Db, Unpackaged Nonoperating Damp Heat)	5...95% noncondensing
Vibration IEC 60068-2-6 (Test Fc, Operating)	2 g @ 10...500 Hz
Shock, operating IEC 60068-2-27 (Test Ea, Unpackaged Shock)	30 g

Environmental Specifications - 1756-IF16H

Attribute	1756-IF16H
Shock, nonoperating IEC 60068-2-27 (Test Ea, Unpackaged Shock)	50 g
Emissions	CISPR 11: Group 1, Class A
ESD immunity IEC 61000-4-2	6 kV contact discharges 8 kV air discharges
Radiated RF immunity IEC 61000-4-3	10V/m with 1 kHz sine-wave 80% AM from 80... 2000 MHz 10V/m with 200 Hz 50% Pulse 100% AM @ 900 MHz 10V/m with 200 Hz 50% Pulse 100% AM @ 1890 MHz 1V/m with 1 kHz sine-wave 80% AM from 2000...2700 MHz
EFT/B immunity IEC 61000-4-4	±3 kV at 5 kHz on shielded signal ports
Surge transient immunity IEC 61000-4-5	±2 kV line-earth (CM) on shielded signal ports
Conducted RF immunity IEC 61000-4-6	10V rms with 1 kHz sine-wave 80% AM from 150 kHz...80 MHz on shielded signal ports

Certifications - 1756-IF16H

Certification⁽¹⁾	1756-IF16H
c-UL-us	UL Listed Industrial Control Equipment, certified for US and Canada. See UL File E65584. UL Listed for Class 1, Division 2 Group A,B,C,D Hazardous Locations, certified for U.S. and Canada. See UL File E194810.
CE	European Union 2004/108/IEC EMC Directive, compliant with: <ul style="list-style-type: none"> • EN 61326-1; Meas./Control/Lab., Industrial Requirements • EN 61000-6-2; Industrial Immunity • EN 61000-6-4; Industrial Emissions • EN 61131-2; Programmable Controllers (Clause 8, Zone A & B)
C-Tick	Australian Radiocommunications Act, compliant with: AS/NZS CISPR 11; Industrial Emissions
Ex	European Union 94/9/EC ATEX Directive, compliant with: <ul style="list-style-type: none"> • EN 60079-15; Potentially Explosive Atmospheres, Protection "n" • EN 60079-0; General Requirements II 3 G Ex nA IIC T4 X

(1) When marked. See the Product Certification link at <http://www.ab.com> for Declarations of Conformity, Certificates, and other certification details.

1756-IF4FXOF2F

ControlLogix high-speed input/output analog module

1756-IF4FXOF2F Current

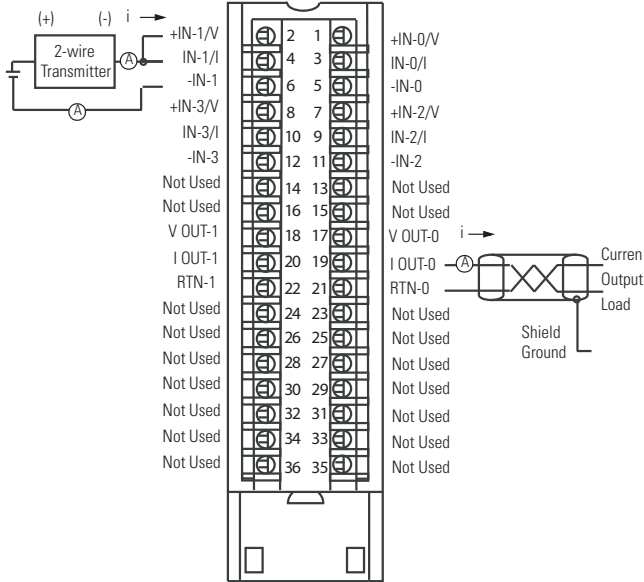

1756-IF4FXOF2F Voltage

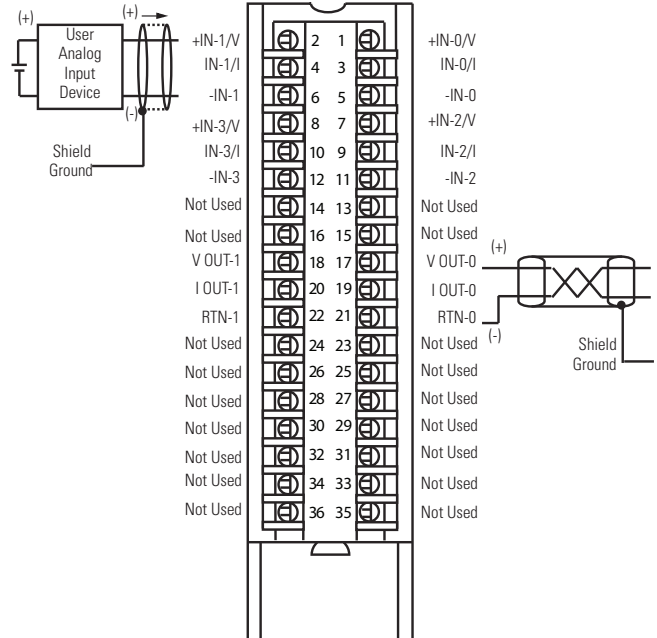

A = Inline field device (such as a strip chart recorder or meter)

Technical Specifications - 1756-IF4FXOF2

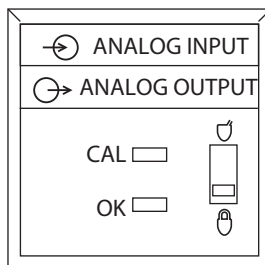

Attribute	1756-IF4FXOF2
Current draw at 5.1V	375 mA
Current draw at 24V	100 mA
Total backplane power	4.3 W
Power dissipation, max	Voltage: 4.3 W Current: 4.7 W
Thermal dissipation	Voltage: 14.66 BTU/hr Current: 16.02 BTU/hr
Data format	Integer mode (left justified, 2s complement) IEEE 32-bit floating point
Isolation voltage	250V (continuous), basic insulation type, inputs and outputs to backplane No isolation between individual inputs or outputs Routine tested at 1350V AC for 2 s
Module keying	Electronic, software configurable
Removable terminal block	1756-TBCH 1756-TBS6H
RTB keying	User-defined mechanical
Slot width	1
Wire category	2 ⁽¹⁾
North American temperature code	T4A
IEC temperature code	T4
Enclosure type	None (open-style)

(1) Use this conductor category information for planning conductor routing as described in the system-level installation manual. See the Industrial Automation Wiring and Grounding Guidelines, publication [1770-4.1](#).

Input Specifications - 1756-IF4FXOF2

Attribute	Inputs
Number	4 high-speed, sub-millisecond, differential
Input range	± 10.5V 0...10.5V 0...5.25V 0...21 mA (over-range indication when exceeded)
Resolution	Approx. 14 bits across ±10.5V DC (21V total) ±10.5V range: 1.3 mV/bit, 14-bit effective 0...10.5V range: 1.3 mV/bit, 13-bit effective 0...5.25V range: 1.3 mV/bit, 12-bit effective Approx. 12 bits across 21 mA 0...21 mA range: 5.25 µA/bit
Repeatability	±1 Least Significant Bit (LSB) ⁽¹⁾
Input impedance	Voltage: >1 MΩ Current: 249 Ω
Open circuit detection	Positive full-scale reading within 1 s
Overvoltage protection	Voltage: 30V DC Current: 8V AC/DC
Calibrated accuracy @ 25 °C (77 °F)	0.05% of range immediately after calibration Better than 0.1% of range within calibration interval
Calibration interval	12 months
Gain drift with temperature	Voltage: 25 ppm/°C max Current: 35 ppm/°C max
Module error	0.2% of range
Module scan time	300 µs min ⁽²⁾
Input conversion method	Successive approximation

(1) Repeatability is defined as the stability of the input channel reading when a steady state signal is applied, for example, ±1 LSB is one count (1.3 mV) from the nominal reading.

(2) 300 µs min for 1756-IF4FXOF2F, Series B, firmware revision 3.x or greater. 400 µs min for 1756-IF4FXOF2F, Series A, firmware revision 1.x.

Output Specifications - 1756-IF4FXOF2

Attribute	Outputs
Number	2 high-speed voltage or current
Output range	± 10.4V 0...21 mA
Resolution	13 bits across 21 mA = 2.8 µA/bit 14 bits across 21.8V = 1.3 mV/bit
Open circuit detection	Current output only (Output must be set to >0.1 mA)
Overvoltage protection	24V DC
Short circuit protection	Electronically current limited to 21 mA or less
Drive capability	Voltage: >2000 Ω Current: 0...750 Ω
Output settling time	< 2 ms to 95% of final value with resistive loads
Calibrated accuracy @ 25 °C (77 °F)	0.05% of range immediately after calibration Better than 0.1% of range within calibration interval
Calibration interval	12 months
Offset drift	50 µV/°C 1 µA/°C
Gain drift with temperature	Voltage: 25 ppm/°C max Current: 50 ppm/°C max
Module error	Voltage: 0.2% of range Current: 0.3% of range
Update period for all channels (RPI), min	1 ms
Output conversion method	R-Ladder DAC, monotonicity with no missing codes

Environmental Specifications - 1756-IF4FXOF2

Attribute	1756-IF4FXOF2
Temperature, operating IEC 60068-2-1 (Test Ad, Operating Cold), IEC 60068-2-2 (Test Bd, Operating Dry Heat), IEC 60068-2-14 (Test Nb, Operating Thermal Shock)	0...60 °C (32...140 °F)
Temperature, surrounding air, max	60 °C (140 °F)
Temperature, storage IEC 60068-2-1 (Test Ab, Unpackaged Nonoperating Cold), IEC 60068-2-2 (Test Bb, Unpackaged Nonoperating Dry Heat), IEC 60068-2-14 (Test Na, Unpackaged Nonoperating Thermal Shock)	-40...85 °C (-40...185 °F)
Relative humidity IEC 60068-2-30 (Test Db, Unpackaged Nonoperating Damp Heat)	5...95% noncondensing
Vibration IEC 60068-2-6 (Test Fc, Operating)	2 g @ 10...500 Hz
Shock, operating IEC 60068-2-27 (Test Ea, Unpackaged Shock)	30 g
Shock, nonoperating IEC 60068-2-27 (Test Ea, Unpackaged Shock)	50 g
Emissions	CISPR 11: Group 1, Class A
ESD immunity IEC 61000-4-2	6 kV contact discharges 8 kV air discharges
Radiated RF immunity IEC 61000-4-3	10V/m with 1 kHz sine-wave 80% AM from 80... 2000 MHz 10V/m with 200 Hz 50% Pulse 100% AM @ 900 MHz 10V/m with 200 Hz 50% Pulse 100% AM @ 1890 MHz 3V/m with 1 kHz sine-wave 80% AM from 2000...2700 MHz

Environmental Specifications - 1756-IF4FXOF2

Attribute	1756-IF4FXOF2
EFT/B immunity IEC 61000-4-4	±2 kV at 5 kHz on shielded signal ports
Surge transient immunity IEC 61000-4-5	±2 kV line-earth (CM) on shielded signal ports
Conducted RF immunity IEC 61000-4-6	10V rms with 1 kHz sine-wave 80% AM from 150 kHz...80 MHz on shielded signal ports

Certifications - 1756-IF4FXOF2

Certification ⁽¹⁾	1756-IF4FXOF2
UL	UL Listed Industrial Control Equipment, certified for US and Canada. See UL File E65584.
CSA	CSA Certified Process Control Equipment. See CSA File LR54689C. CSA Certified Process Control Equipment for Class I, Division 2 Group A,B,C,D Hazardous Locations. See CSA File LR69960C.
CE	European Union 2004/108/IEC EMC Directive, compliant with: <ul style="list-style-type: none"> • EN 61326-1; Meas./Control/Lab., Industrial Requirements • EN 61000-6-2; Industrial Immunity • EN 61000-6-4; Industrial Emissions • EN 61131-2; Programmable Controllers (Clause 8, Zone A & B) European Union 2006/95/EC LVD, compliant with: <ul style="list-style-type: none"> • EN 61131-2; Programmable Controllers (Clause 11)
C-Tick	Australian Radiocommunications Act, compliant with: AS/NZS CISPR 11; Industrial Emissions
Ex	European Union 94/9/EC ATEX Directive, compliant with: <ul style="list-style-type: none"> • EN 60079-15; Potentially Explosive Atmospheres, Protection "n" • EN 60079-0; General Requirements II 3 G Ex nA IIC T4 X
FM	FM Approved Equipment for use in Class I Division 2 Group A,B,C,D Hazardous Locations

(1) When marked. See the Product Certification link at <http://www.ab.com> for Declarations of Conformity, Certificates, and other certification details.

1756-IG16

ControlLogix TTL input module

Standard Wiring

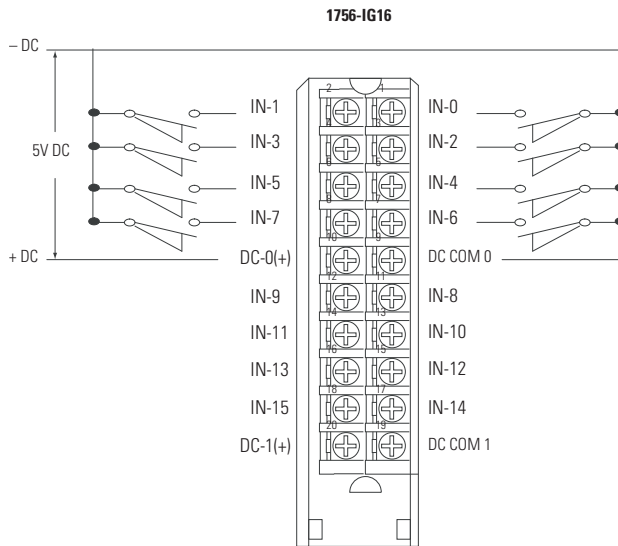

CE Compliant Wiring

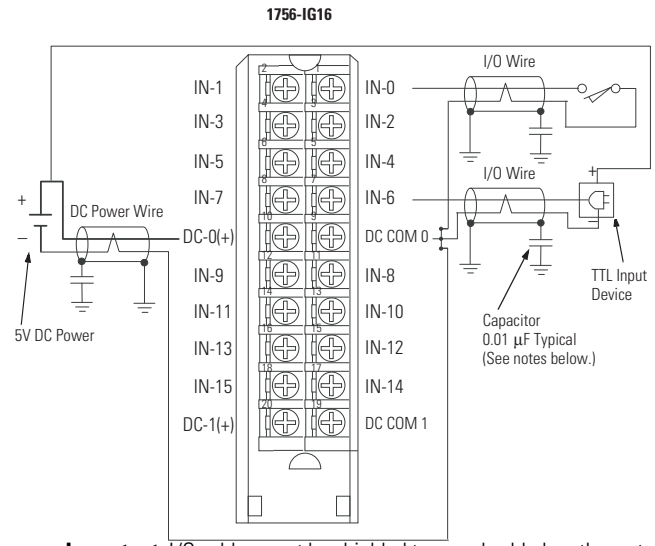

Important: I/O cables must be shielded type and cable length must be <10 m (32.8 ft) for maximum EMI noise immunity.

Simplified Schematic

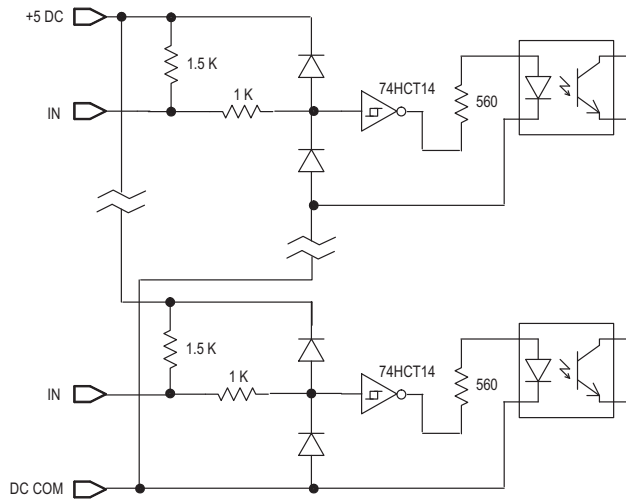

Low to True Format - 1756-IG16

- -0.2...0.8V = Input guaranteed to be in on-state
- 0.8...2.0V = Input state not guaranteed
- 2.0...5.5V = Input guaranteed to be in off-state

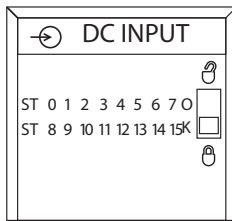

Technical Specifications - 1756-IG16

Attribute	1756-IG16
Inputs	16 (8 points/group)
Voltage category	5V DC TTL source (Low=True) ⁽¹⁾
Operating voltage range	4.5...5.5V DC 50 mV P-P ripple max
Input delay time OFF to ON (5-to-0V DC transition) ON to OFF (0-to-5V DC transition)	Hardware delay: 270 μ s nom/450 μ s max + filter time User-selectable filter time: 0, 1, or 2 ms Hardware delay: 390 μ s nom/ 700 μ s max + filter time User-selectable filter time: 0, 1, 2, 9, or 18 ms
Current draw @ 5.1V	110 mA
Current draw @ 24V	2 mA
Total backplane power	0.61 W
Power dissipation, max	1.4 W @ 60 °C (140 °F)
Thermal dissipation	4.8 BTU/hr @ 60 °C (140 °F)
Off-state voltage, max	2V
Off-state current, max	4.1 mA
Input impedance, max	1.4 k Ω min 1.5 k Ω typical
Input current, nom	3.7 mA @ 5V DC
Input current, max	4.1 mA @ 5V DC
Cyclic update time	200 μ s...750 ms
Change of state	Software configurable
Timestamp of inputs	\pm 200 μ s
Isolation voltage	250V (continuous), basic insulation type, inputs-to-backplane, and input group-to-group No isolation between individual group inputs Routine tested @ 1350V AC for 2 s
Module keying	Electronic, software configurable
Removable terminal block housing	1756-TBNH 1756-TBSH
RTB keying	User-defined mechanical
Slot width	1
Wire category	2 ⁽²⁾
North American temperature code	T5
IEC temperature code	T5
Enclosure type	None (open-style)
Reverse polarity protection	No

(1) TTL inputs are inverted (-0.2 to +0.8 = low voltage = True = On.) Use a NOT instruction in your program to convert to traditional True - High logic.

(2) Use this conductor category information for planning conductor routing as described in the system-level installation manual. See the Industrial Automation Wiring and Grounding Guidelines, publication [1770-4.1](#).

Environmental Specifications - 1756-IG16

Attribute	1756-IG16
Temperature, operating IEC 60068-2-1 (Test Ad, Operating Cold), IEC 60068-2-2 (Test Bd, Operating Dry Heat), IEC 60068-2-14 (Test Nb, Operating Thermal Shock)	0...60 °C (32...140 °F)
Temperature, surrounding air, max	60 °C (140 °F)
Temperature, storage IEC 60068-2-1 (Test Ab, Unpackaged Nonoperating Cold), IEC 60068-2-2 (Test Bb, Unpackaged Nonoperating Dry Heat), IEC 60068-2-14 (Test Na, Unpackaged Nonoperating Thermal Shock)	-40...85 °C (-40...185 °F)
Relative humidity IEC 60068-2-30 (Test Db, Unpackaged Nonoperating Damp Heat)	5...95% noncondensing
Vibration IEC 60068-2-6 (Test Fc, Operating)	2 g @ 10...500 Hz
Shock, operating IEC 60068-2-27 (Test Ea, Unpackaged Shock)	30 g
Shock, nonoperating IEC 60068-2-27 (Test Ea, Unpackaged Shock)	50 g
Emissions	CISPR 11: Group 1, Class A
ESD immunity IEC 61000-4-2	6 kV contact discharges 8 kV air discharges
Radiated RF immunity IEC 61000-4-3	10V/m with 1 kHz sine-wave 80% AM from 80...2000 MHz 10V/m with 200 Hz 50% Pulse 100% AM @ 900 MHz 10V/m with 200 Hz 50% Pulse 100% AM @ 1890 MHz 3V/m with 1 kHz sine-wave 80% AM from 2000...2700 MHz
EFT/B immunity IEC 61000-4-4	±1 kV at 5 kHz on signal ports
Conducted RF immunity IEC 61000-4-6	10V rms with 1 kHz sine-wave 80% AM from 150 kHz...80 MHz

Certifications - 1756-IG16

Certification ⁽¹⁾	1756-IG16
UL	UL Listed Industrial Control Equipment, certified for US and Canada. See UL File E65584.
CSA	CSA Certified Process Control Equipment. See CSA File LR54689C. CSA Certified Process Control Equipment for Class I, Division 2 Group A,B,C,D Hazardous Locations. See CSA File LR69960C.
CE	European Union 2004/108/IEC EMC Directive, compliant with: <ul style="list-style-type: none"> • EN 61326-1; Meas./Control/Lab., Industrial Requirements • EN 61000-6-2; Industrial Immunity • EN 61000-6-4; Industrial Emissions • EN 61131-2; Programmable Controllers (Clause 8, Zone A & B) European Union 2006/95/EC LVD, compliant with: <ul style="list-style-type: none"> • EN 61131-2; Programmable Controllers (Clause 11)
C-Tick	Australian Radiocommunications Act, compliant with: AS/NZS CISPR 11; Industrial Emissions
Ex	European Union 94/9/EC ATEX Directive, compliant with: <ul style="list-style-type: none"> • EN 60079-15; Potentially Explosive Atmospheres, Protection "n" • EN 60079-0; General Requirements II 3 G Ex nA IIC T5 X

(1) When marked. See the Product Certification link at <http://www.ab.com> for Declarations of Conformity, Certificates, and other certification details.

1756-IH16I

ControlLogix DC (90...146V) isolated input module

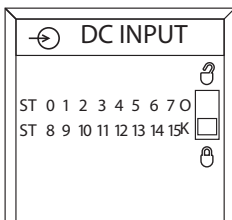
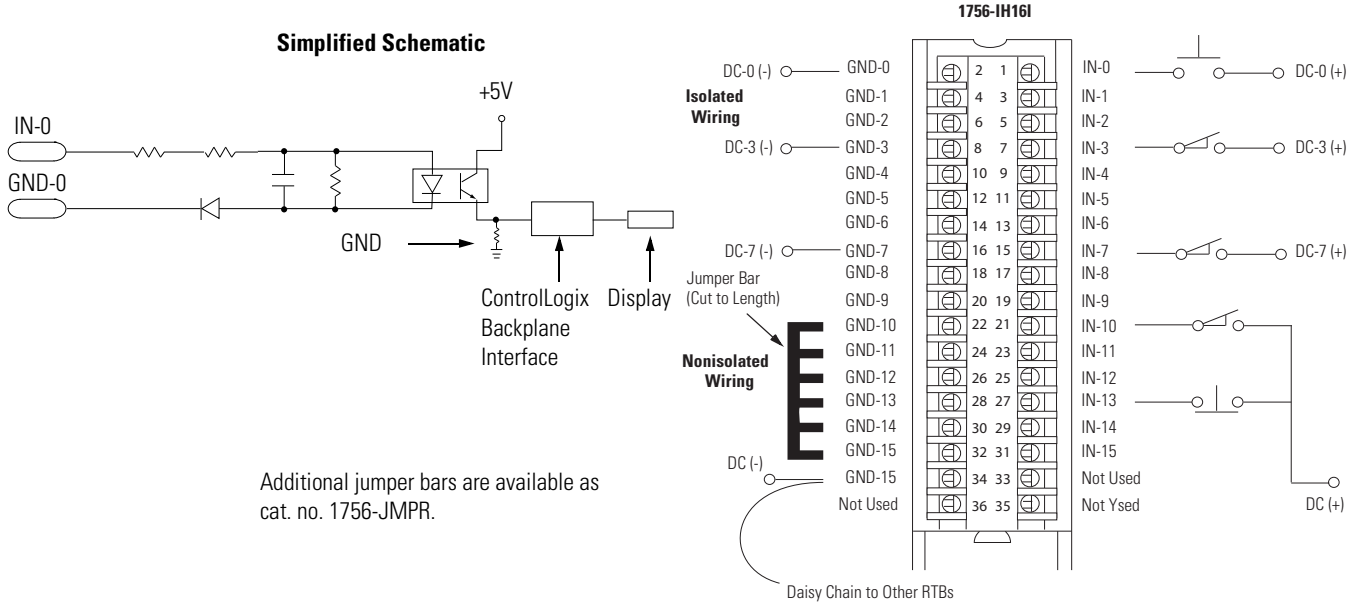

Technical Specifications - 1756-IH16I

Attribute	1756-IH16I
Inputs	16 individually isolated
Voltage category	125V DC sink/source
Operating voltage range	90...146V DC ⁽¹⁾
Input voltage, nom	125V DC
Input delay time OFF to ON	Hardware delay: 2 ms max + filter time User-selectable filter time: 0, 1, or 2 ms
ON to OFF	Hardware delay: 6 ms max + filter time User-selectable filter time: 0, 1, 2, 9, or 18 ms
Current draw @ 5.1V	125 mA
Current draw @ 24V	3 mA
Total backplane power	0.71 W
Power dissipation, max	5 W @ 60 °C (140 °F)
Thermal dissipation	17.05 BTU/hr
Off-state voltage, max	20V DC
Off-state current, max	0.8 mA
On-state current, min	1 mA @ 90V DC
On-state current, max	3 mA @ 146V DC

Technical Specifications - 1756-IH16I

Attribute	1756-IH16I
On-state voltage Derated as follows	90...146V DC 90...146V DC @ 50 °C (122 °F), 12 Channels ON 90...132V DC @ 55 °C (131 °F), 14 Channels ON 90...125V DC @ 60 °C (140 °F), 16 Channels ON 90...146V DC @ 30 °C (86 °F), 16 Channels ON
Inrush current, max	250 mA
Input impedance, max	48.67 kΩ @ 146V DC
Cyclic update time	200 μs...750 ms
Change of state	Software configurable
Timestamp of inputs	±200 μs
Isolation voltage	250V (continuous), basic insulation type, inputs-to-backplane, and input-to-input Routine tested @ 1350V AC for 2 s
Module keying	Electronic, software configurable
Removable terminal block housing	1756-TBCH 1756-TBS6H
RTB keying	User-defined mechanical
Slot width	1
Wire category	1 ⁽²⁾
North American temperature code	T4
Enclosure type	None (open-style)
Reverse polarity protection	Yes

- (1) 90...146V DC @ 50 °C (122 °F), 12 channels on
90...132V DC @ 55 °C (131 °F), 14 channels on
90...125V DC @ 60 °C (140 °F), 16 channels on
90...146V DC @ 30 °C (86 °F), 16 channels on.

- (2) Use this conductor category information for planning conductor routing as described in the system-level installation manual. See the Industrial Automation Wiring and Grounding Guidelines, publication [1770-4.1](#).

Environmental Specifications - 1756-IH16I

Attribute	1756-IH16I
Temperature, operating IEC 60068-2-1 (Test Ad, Operating Cold), IEC 60068-2-2 (Test Bd, Operating Dry Heat), IEC 60068-2-14 (Test Nb, Operating Thermal Shock)	0...60 °C (32...140 °F)
Temperature, surrounding air, max	60 °C (140 °F)
Temperature, storage IEC 60068-2-1 (Test Ab, Unpackaged Nonoperating Cold), IEC 60068-2-2 (Test Bb, Unpackaged Nonoperating Dry Heat), IEC 60068-2-14 (Test Na, Unpackaged Nonoperating Thermal Shock)	-40...85 °C (-40...185 °F)
Relative humidity IEC 60068-2-30 (Test Db, Unpackaged Nonoperating Damp Heat)	5...95% noncondensing
Vibration IEC 60068-2-6 (Test Fc, Operating)	2 g @ 10...500 Hz
Shock, operating IEC 60068-2-27 (Test Ea, Unpackaged Shock)	30 g
Shock, nonoperating IEC 60068-2-27 (Test Ea, Unpackaged Shock)	50 g

Environmental Specifications - 1756-IH16I

Attribute	1756-IH16I
Emissions	CISPR 11: Group 1, Class A
ESD immunity IEC 61000-4-2	6 kV contact discharges 8 kV air discharges
Radiated RF immunity IEC 61000-4-3	10V/m with 1 kHz sine-wave 80% AM from 80... 2000 MHz 10V/m with 200 Hz 50% Pulse 100% AM @ 900 MHz 10V/m with 200 Hz 50% Pulse 100% AM @ 1890 MHz 3V/m with 1 kHz sine-wave 80% AM from 2000...2700 MHz
EFT/B immunity IEC 61000-4-4	±4 kV at 5 kHz on signal ports
Surge transient immunity IEC 61000-4-5	±1 kV line-line (DM) and ±2 kV line-earth (CM) on signal ports
Conducted RF immunity IEC 61000-4-6	10V rms with 1 kHz sine-wave 80% AM from 150 kHz...80 MHz
Oscillatory surge withstand IEEE C37.90.1	3 kV

Certifications - 1756-IH16I

Certification⁽¹⁾	1756-IH16I
UL	UL Listed Industrial Control Equipment, certified for US and Canada. See UL File E65584.
CSA	CSA Certified Process Control Equipment. See CSA File LR54689C. CSA Certified Process Control Equipment for Class I, Division 2 Group A,B,C,D Hazardous Locations. See CSA File LR69960C.
CE	European Union 2004/108/IEC EMC Directive, compliant with: <ul style="list-style-type: none"> • EN 61326-1; Meas./Control/Lab., Industrial Requirements • EN 61000-6-2; Industrial Immunity • EN 61000-6-4; Industrial Emissions • EN 61131-2; Programmable Controllers (Clause 8, Zone A & B) European Union 2006/95/EC LVD, compliant with: <ul style="list-style-type: none"> • EN 61131-2; Programmable Controllers
C-Tick	Australian Radiocommunications Act, compliant with: AS/NZS CISPR 11; Industrial Emissions
FM	FM Approved Equipment for use in Class I Division 2 Group A,B,C,D Hazardous Locations

(1) When marked. See the Product Certification link at <http://www.ab.com> for Declarations of Conformity, Certificates, and other certification details.

1756-IH16ISOE

ControlLogix DC (90...140V) sequence of events input module

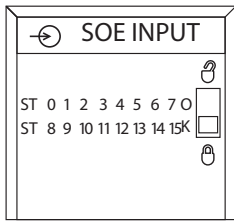
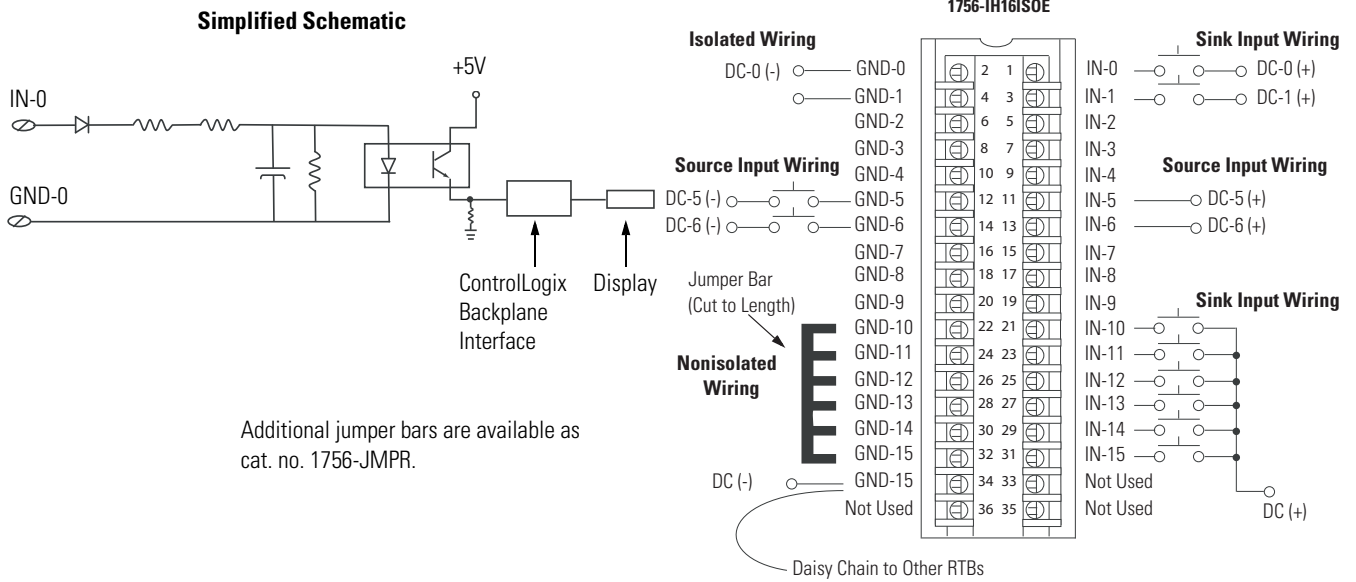

Technical Specifications - 1756-IH16ISOE

Attribute	1756-IH16ISOE
Inputs	16 individually isolated, sequence of events
Voltage category	125V DC sink/source
Operating voltage range	90...140V DC
Input voltage, nom	125V DC
Input delay time OFF to ON	Hardware delay: 10 μs nom/20 μs max + firmware scan: up to 25 μs + filter time: 0...50 ms + ASIC delay: 175 μs (FIFO) or 625 μs (Coordinated System Time per point)
ON to OFF	Hardware delay: 50 μs nom/75 μs max + firmware scan: up to 25 μs + filter time: 0...50 ms + ASIC delay: 175 μs (FIFO) or 625 μs (Coordinated System Time per point)
Current draw @ 5.1V	275 mA\$
Current draw @ 24V	2 mA
Total backplane power	1.3 W
Power dissipation, max	5.5 W @ 60 °C (140 °F)
Thermal dissipation	17.22 BTU/hr
Off-state voltage, max	20V
Off-state current, max	0.3 mA
On-state current, min	1.15 mA @ 90V DC
On-state current, max	1.85 mA @ 140V DC
Input impedance, max	74.8 kΩ

Technical Specifications - 1756-IH16ISOE

Attribute	1756-IH16ISOE
Cyclic update time	200 μ s...750 ms
Change of state	Software configurable
Timestamp of inputs	\pm 100 μ s
Isolation voltage	250V (continuous), basic insulation type, inputs-to-backplane, and input-to-input Routine tested @ 1350V AC for 2 s, inputs-to-backplane
Module keying	Electronic, software configurable
Removable terminal block	1756-TBCH 1756-TBS6H
RTB keying	User-defined mechanical
Slot width	1
Wire category	1 ⁽¹⁾
North American temperature code	T3C
Enclosure type	None (open-style)
Reverse polarity protection	Yes

(1) Use this conductor category information for planning conductor routing as described in the system-level installation manual. See the Industrial Automation Wiring and Grounding Guidelines, publication [1770-4.1](#).

Environmental Specifications - 1756-IH16ISOE

Attribute	1756-IH16ISOE
Temperature, operating IEC 60068-2-1 (Test Ad, Operating Cold), IEC 60068-2-2 (Test Bd, Operating Dry Heat), IEC 60068-2-14 (Test Nb, Operating Thermal Shock)	0...60 °C (32...140 °F)
Temperature, surrounding air, max	60 °C (140 °F)
Temperature, storage IEC 60068-2-1 (Test Ab, Unpackaged Nonoperating Cold), IEC 60068-2-2 (Test Bb, Unpackaged Nonoperating Dry Heat), IEC 60068-2-14 (Test Na, Unpackaged Nonoperating Thermal Shock)	-40...85 °C (-40...185 °F)
Relative humidity IEC 60068-2-30 (Test Db, Unpackaged Nonoperating Damp Heat)	5...95% noncondensing
Vibration IEC 60068-2-6 (Test Fc, Operating)	2 g @ 10...500 Hz
Shock, operating IEC 60068-2-27 (Test Ea, Unpackaged Shock)	30 g
Shock, nonoperating IEC 60068-2-27 (Test Ea, Unpackaged Shock)	50 g
Emissions	CISPR 11: Group 1, Class A
ESD immunity IEC 61000-4-2	6 kV contact discharges 8 kV air discharges
Radiated RF immunity IEC 61000-4-3	10V/m with 1 kHz sine-wave 80% AM from 80... 2000 MHz 10V/m with 200 Hz 50% Pulse 100% AM @ 900 MHz 10V/m with 200 Hz 50% Pulse 100% AM @ 1890 MHz 3V/m with 1 kHz sine-wave 80% AM from 2000...2700 MHz
EFT/B immunity IEC 61000-4-4	\pm 4 kV at 5 kHz on signal ports

Environmental Specifications - 1756-IH16ISOE

Attribute	1756-IH16ISOE
Surge transient immunity IEC 61000-4-5	±1 kV line-line (DM) and ±2 kV line-earth (CM) on signal ports
Conducted RF immunity IEC 61000-4-6	10V rms with 1 kHz sine-wave 80% AM from 150 kHz...80 MHz
Oscillatory surge withstand IEEE C37.90.1	3 kV

Certifications - 1756-IH16ISOE

Certification ⁽¹⁾	1756-IH16ISOE
UL	UL Listed Industrial Control Equipment, certified for US and Canada. See UL File E65584.
CSA	CSA Certified Process Control Equipment. See CSA File LR54689C. CSA Certified Process Control Equipment for Class I, Division 2 Group A,B,C,D Hazardous Locations. See CSA File LR69960C.
CE	European Union 2004/108/IEC EMC Directive, compliant with: <ul style="list-style-type: none"> • EN 61326-1; Meas./Control/Lab., Industrial Requirements • EN 61000-6-2; Industrial Immunity • EN 61000-6-4; Industrial Emissions • EN 61131-2; Programmable Controllers (Clause 8, Zone A & B) European Union 2006/95/EC LVD, compliant with: <ul style="list-style-type: none"> • EN 61131-2; Programmable Controllers (Clause 11)
C-Tick	Australian Radiocommunications Act, compliant with: AS/NZS CISPR 11; Industrial Emissions
TÜV	TÜV Certified for Functional Safety ⁽²⁾ . Capable of SIL 2

(1) When marked. See the Product Certification link at <http://www.ab.com> for Declarations of Conformity, Certificates, and other certification details.

(2) When used with specified firmware revisions and in accordance with application guidelines described in Using ControlLogix in SIL2 Applications Safety Reference Manual, publication [1756-RM001](#).

1756-IM16I

ControlLogix AC (159...265V) input module

Simplified Schematic

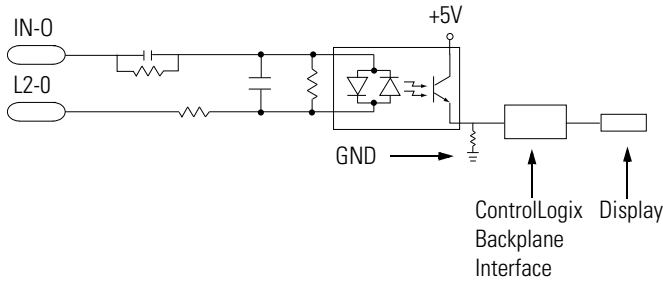

Additional jumper bars are available as cat. no. 1756-JMPR.

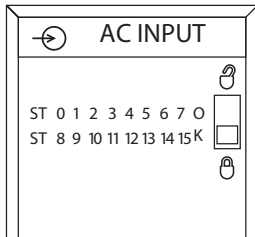
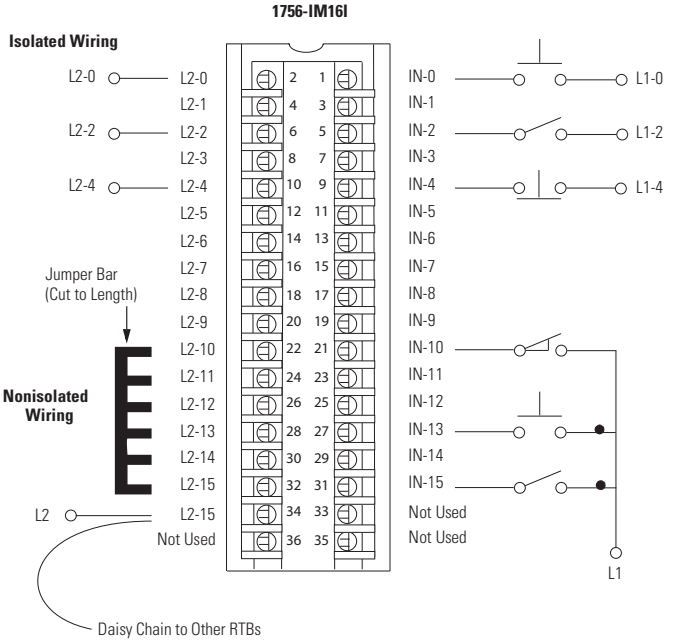

Technical Specifications - 1756-IM16I

Attribute	1756-IM16I
Inputs	16 individually isolated
Voltage category	240V AC
Operating voltage range	159...265V AC, 47...63 Hz ⁽¹⁾
Input voltage, nom	240V AC
Input delay time OFF to ON ON to OFF	Hardware delay: 10 ms max + filter time User-selectable filter time: 1 or 2 ms Hardware delay: 8 ms max + filter time User-selectable filter time: 9 or 18 ms
Current draw @ 5.1V	100 mA
Current draw @ 24V	3 mA
Total backplane power	0.58 W
Power dissipation, max	5.8 W @ 60 °C (140 °F)
Thermal dissipation	19.78 BTU/hr
Off-state voltage, max	40V
Off-state current, max	2.5 mA
On-state current, min	5 mA @ 159V AC, 60 Hz
On-state current, max	13 mA @ 265V AC, 60 Hz

Technical Specifications - 1756-IM16I

Attribute	1756-IM16I
On-state voltage	159...265V AC, 47...63Hz @ 30 °C (86 °F) all channels ON 159...265V AC, 47...63Hz @ 40 °C (104 °F) 8 points ON 159...253V AC, 47...63Hz @ 45 °C (113 °F) all channels ON 159...242V AC, 47...63Hz @ 60 °C (140 °F) all channels ON
Inrush current, max	250 mA
Input impedance, max	20.38 k Ω @ 265V AC, 60 Hz
Cyclic update time	200 μ s...750 ms
Change of state	Software configurable
Timestamp of inputs	\pm 200 μ s
Isolation voltage	250V (continuous), basic insulation type, inputs-to-backplane, and input-to-input Routine tested @ 1350V AC for 2 s
Module keying	Electronic, software configurable
Removable terminal block housing	1756-TBCH 1756-TBS6H
RTB keying	User-defined mechanical
Slot width	1
Wire category	1 ⁽²⁾
North American temperature code	T4
Enclosure type	None (open-style)

- (1) 159...265V AC, 47...63Hz @ 30 °C (86 °F) all channels on
159...265V AC, 47...63Hz @ 40 °C (104 °F) 8 points on
159...253V AC, 47...63Hz @ 45 °C (113 °F) all channels on
159...242V AC, 47...63Hz @ 60 °C (140 °F) all channels on.

- (2) Use this conductor category information for planning conductor routing as described in the system-level installation manual. See the Industrial Automation Wiring and Grounding Guidelines, publication [1770-4.1](#).

Environmental Specifications - 1756-IM16I

Attribute	1756-IM16I
Temperature, operating IEC 60068-2-1 (Test Ad, Operating Cold), IEC 60068-2-2 (Test Bd, Operating Dry Heat), IEC 60068-2-14 (Test Nb, Operating Thermal Shock)	0...60 °C (32...140 °F)
Temperature, surrounding air, max	60 °C (140 °F)
Temperature, storage IEC 60068-2-1 (Test Ab, Unpackaged Nonoperating Cold), IEC 60068-2-2 (Test Bb, Unpackaged Nonoperating Dry Heat), IEC 60068-2-14 (Test Na, Unpackaged Nonoperating Thermal Shock)	-40...85 °C (-40...185 °F)
Relative humidity IEC 60068-2-30 (Test Db, Unpackaged Nonoperating Damp Heat)	5...95% noncondensing
Vibration IEC 60068-2-6 (Test Fc, Operating)	2 g @ 10...500 Hz
Shock, operating IEC 60068-2-27 (Test Ea, Unpackaged Shock)	30 g
Shock, nonoperating IEC 60068-2-27 (Test Ea, Unpackaged Shock)	50 g

Environmental Specifications - 1756-IM16I

Attribute	1756-IM16I
Emissions	CISPR 11: Group 1, Class A
ESD immunity IEC 61000-4-2	6 kV contact discharges 8 kV air discharges
Radiated RF immunity IEC 61000-4-3	10V/m with 1 kHz sine-wave 80% AM from 80... 2000 MHz 10V/m with 200 Hz 50% Pulse 100% AM @ 900 MHz 10V/m with 200 Hz 50% Pulse 100% AM @ 1890 MHz 3V/m with 1 kHz sine-wave 80% AM from 2000...2700 MHz
EFT/B immunity IEC 61000-4-4	±4 kV at 5 kHz on signal ports
Surge transient immunity IEC 61000-4-5	±1 kV line-line (DM) and ±2 kV line-earth (CM) on signal ports
Conducted RF immunity IEC 61000-4-6	10V rms with 1 kHz sine-wave 80% AM from 150 kHz...80 MHz

Certifications - 1756-IM16I

Certification⁽¹⁾	1756-IM16I
FM	FM Approved Equipment for use in Class I Division 2 Group A,B,C,D Hazardous Locations
CSA	CSA Certified Process Control Equipment. See CSA File LR54689C. CSA Certified Process Control Equipment for Class I, Division 2 Group A,B,C,D Hazardous Locations. See CSA File LR69960C.
CE	European Union 2004/108/IEC EMC Directive, compliant with: <ul style="list-style-type: none"> • EN 61326-1; Meas./Control/Lab., Industrial Requirements • EN 61000-6-2; Industrial Immunity • EN 61000-6-4; Industrial Emissions • EN 61131-2; Programmable Controllers (Clause 8, Zone A & B) European Union 2006/95/EC LVD, compliant with: <ul style="list-style-type: none"> • EN 61131-2; Programmable Controllers
C-Tick	Australian Radiocommunications Act, compliant with: AS/NZS CISPR 11; Industrial Emissions
FM	FM Approved Equipment for use in Class I Division 2 Group A,B,C,D Hazardous Locations

(1) When marked. See the Product Certification link at <http://www.ab.com> for Declarations of Conformity, Certificates, and other certification details.

1756-IN16

ControlLogix AC (10...30V) input module

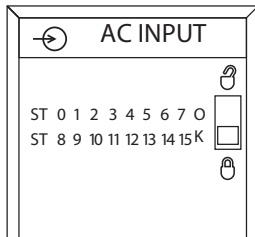
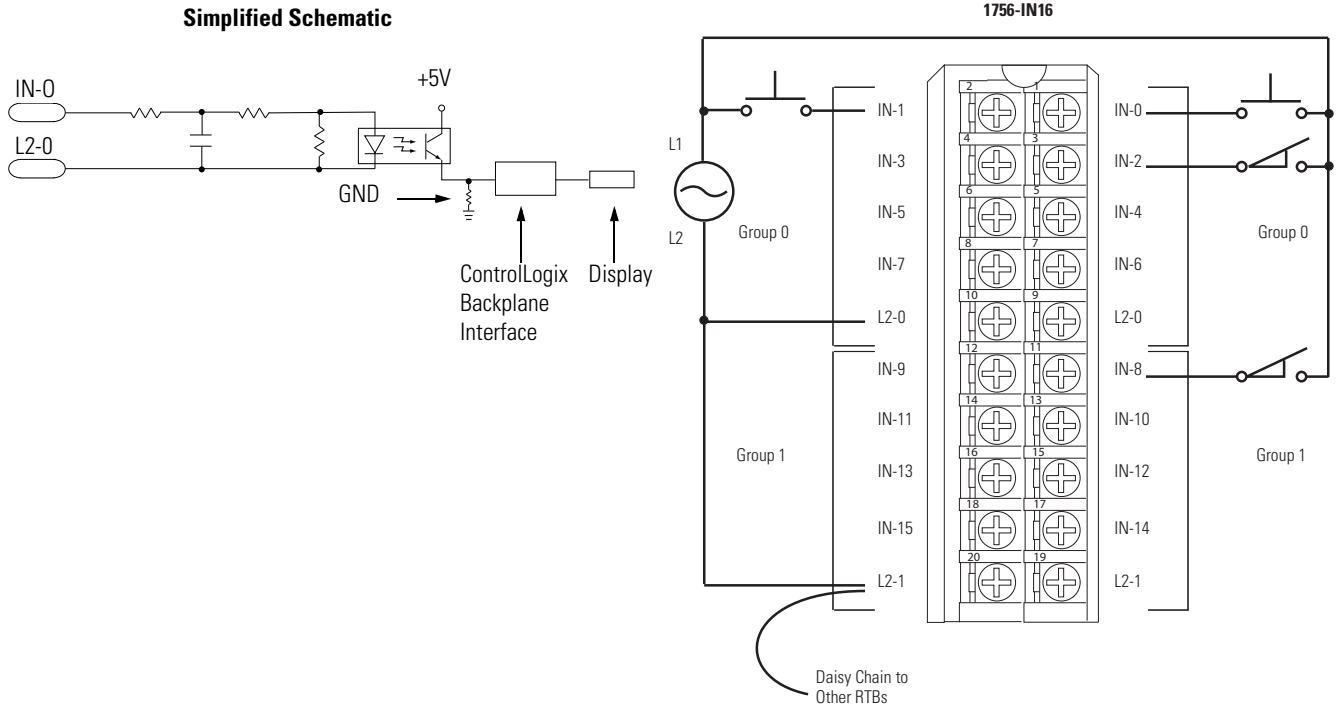

Technical Specifications - 1756-IN16

Attribute	1756-IN16
Inputs	16 (8 points/group)
Voltage category	24V AC
Operating voltage range	10...30V AC, 47...63 Hz
Input voltage, nom	24V AC
Input delay time OFF to ON	Hardware delay: 10 ms max + filter time User-selectable filter time: 0, 1, or 2 ms
ON to OFF	Hardware delay: 10 ms max + filter time User-selectable filter time: 9 or 18 ms
Current draw @ 5.1V	100 mA
Current draw @ 24V	2 mA
Total backplane power	0.56 W
Power dissipation, max	5.1 W @ 60 °C (140 °F)
Thermal dissipation	17.39 BTU/hr
Off-state voltage, max	5V
Off-state current, max	2.75 mA
On-state current, min	5 mA @ 10V AC, 60 Hz
On-state current, max	1.2 mA @ 30V AC, 60 Hz
Inrush current, max	250 mA

Technical Specifications - 1756-IN16

Attribute	1756-IN16
Input impedance, max	2.5 k Ω @ 30V AC, 60 Hz
Cyclic update time	200 μ s...750 ms
Change of state	Software configurable
Timestamp of inputs	\pm 200 μ s
Isolation voltage	250V (continuous), basic insulation type, inputs-to-backplane, and input group-to-group No isolation between individual group inputs Routine tested @ 1350V AC for 2 s
Module keying	Electronic, software configurable
Removable terminal block housing	1756-TBNH 1756-TBSH
RTB keying	User-defined mechanical
Slot width	1
Wire category	1 ⁽¹⁾
North American temperature code	T3C
IEC temperature code	T3
Enclosure type	None (open-style)

(1) Use this conductor category information for planning conductor routing as described in the system-level installation manual. See the Industrial Automation Wiring and Grounding Guidelines, publication [1770-4.1](#).

Environmental Specifications - 1756-IN16

Attribute	1756-IN16
Temperature, operating IEC 60068-2-1 (Test Ad, Operating Cold), IEC 60068-2-2 (Test Bd, Operating Dry Heat), IEC 60068-2-14 (Test Nb, Operating Thermal Shock)	0...60 °C (32...140 °F)
Temperature, surrounding air, max	60 °C (140 °F)
Temperature, storage IEC 60068-2-1 (Test Ab, Unpackaged Nonoperating Cold), IEC 60068-2-2 (Test Bb, Unpackaged Nonoperating Dry Heat), IEC 60068-2-14 (Test Na, Unpackaged Nonoperating Thermal Shock)	-40...85 °C (-40...185 °F)
Relative humidity IEC 60068-2-30 (Test Db, Unpackaged Nonoperating Damp Heat)	5...95% noncondensing
Vibration IEC 60068-2-6 (Test Fc, Operating)	2 g @ 10...500 Hz
Shock, operating IEC 60068-2-27 (Test Ea, Unpackaged Shock)	30 g
Shock, nonoperating IEC 60068-2-27 (Test Ea, Unpackaged Shock)	50 g
Emissions	CISPR 11: Group 1, Class A
ESD immunity IEC 61000-4-2	6 kV contact discharges 8 kV air discharges
Radiated RF immunity IEC 61000-4-3	10V/m with 1 kHz sine-wave 80% AM from 80...2000 MHz 10V/m with 200 Hz 50% Pulse 100% AM @ 900 MHz 10V/m with 200 Hz 50% Pulse 100% AM @ 1890 MHz 3V/m with 1 kHz sine-wave 80% AM from 2000...2700 MHz

Environmental Specifications - 1756-IN16

Attribute	1756-IN16
EFT/B immunity IEC 61000-4-4	±4 kV at 5 kHz on signal ports
Surge transient immunity IEC 61000-4-5	±1 kV line-line (DM) and ±2 kV line-earth (CM) on signal ports
Conducted RF immunity IEC 61000-4-6	10V rms with 1 kHz sine-wave 80% AM from 150 kHz...80 MHz

Certifications - 1756-IN16

Certification ⁽¹⁾	1756-IN16
UL	UL Listed Industrial Control Equipment, certified for US and Canada. See UL File E65584.
CSA	CSA Certified Process Control Equipment. See CSA File LR54689C. CSA Certified Process Control Equipment for Class I, Division 2 Group A,B,C,D Hazardous Locations. See CSA File LR69960C.
CE	European Union 2004/108/IEC EMC Directive, compliant with: <ul style="list-style-type: none"> • EN 61326-1; Meas./Control/Lab., Industrial Requirements • EN 61000-6-2; Industrial Immunity • EN 61000-6-4; Industrial Emissions • EN 61131-2; Programmable Controllers (Clause 8, Zone A & B) European Union 2006/95/EC LVD, compliant with: <ul style="list-style-type: none"> • EN 61131-2; Programmable Controllers (Clause 11)
C-Tick	Australian Radiocommunications Act, compliant with: AS/NZS CISPR 11; Industrial Emissions
Ex	European Union 94/9/EC ATEX Directive, compliant with: <ul style="list-style-type: none"> • EN 60079-15; Potentially Explosive Atmospheres, Protection "n" • EN 60079-0; General Requirements II 3 G Ex nA IIC T3 X
FM	FM Approved Equipment for use in Class I Division 2 Group A,B,C,D Hazardous Locations

(1) When marked. See the Product Certification link at <http://www.ab.com> for Declarations of Conformity, Certificates, and other certification details.

1756-IR6I

ControlLogix temperature sensing analog input module

1756-IR6I 3-wire RTD

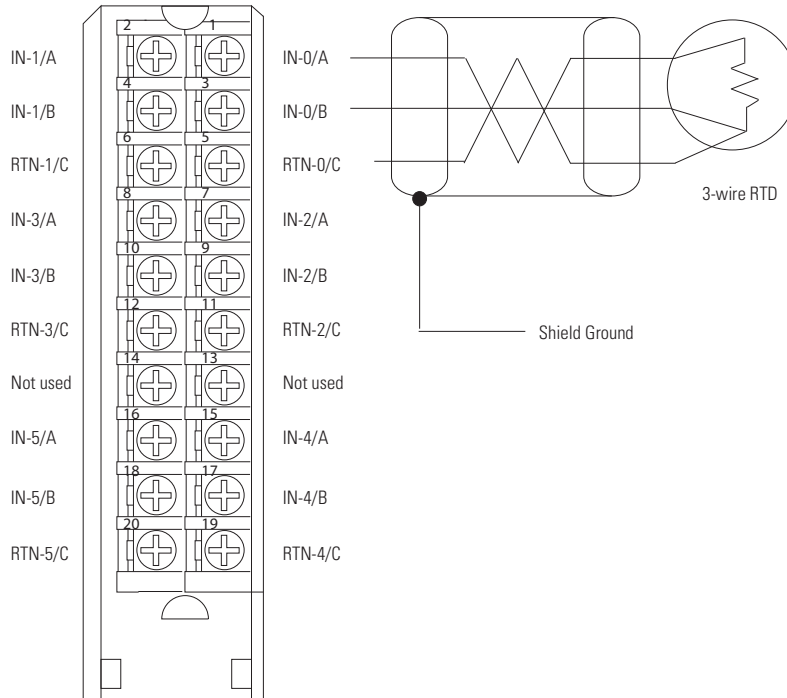

IMPORTANT: For 2-wire resistor applications including calibration, make sure IN-x/B and RTN-x/C are shorted together as shown.

1756-IR6I 4-wire RTD

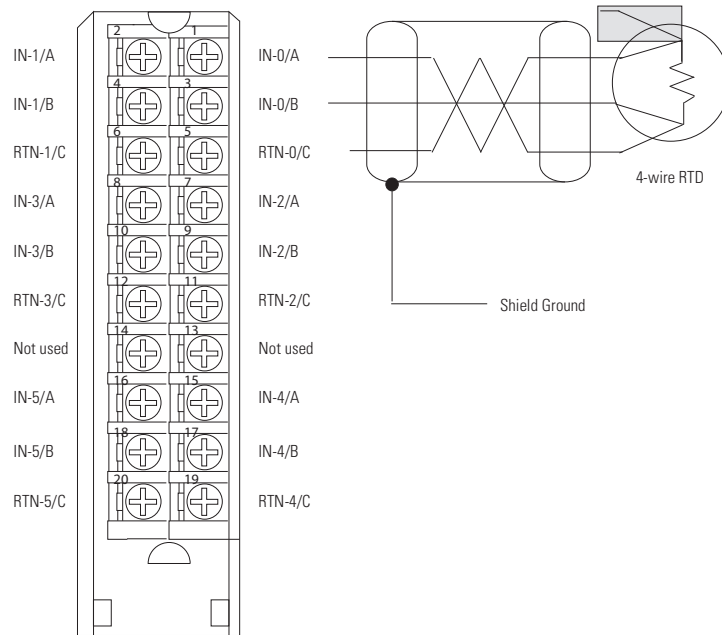

Wiring is exactly the same as the 3-wire RTD with one wire left open.

Signal and User Counts - 1756-IR6I

Range	Low Signal and User Counts	High Signal and User Counts
1...487 Ω	0.859068653 Ω -32768 counts	507.862 Ω 32767 counts
2...1000 Ω	2 Ω -32768 counts	1016.502 Ω 32767 counts
4...2000 Ω	4 Ω -32768 counts	2033.780 Ω 32767 counts
8...4020 Ω	8 Ω -32768 counts	4068.392 Ω 32767 counts

Technical Specifications - 1756-IR6I

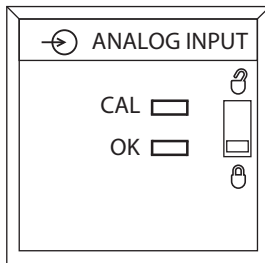

Attribute	1756-IR6I
Inputs	6 individually isolated RTD
Input range	1...487 Ω 2...1000 Ω 4...2000 Ω 8...4020 Ω
Resolution	16 bits 1...487 Ω: 7.7 mΩ/bit 2...1000 Ω: 15 mΩ/bit 4...2000 Ω: 30 mΩ/bit 8...4020 Ω: 60 mΩ/bit

Technical Specifications - 1756-IR6I

Attribute	1756-IR6I
Sensors supported	100, 200, 500, 1000 Ω Platinum, alpha=385 100, 200, 500, 1000 Ω Platinum, alpha=3916 120 Ω Nickel, alpha=672 100, 120, 200, 500 Ω Nickel, alpha=618 10 Ω Copper
Current draw @ 5.1V	250 mA
Current draw @ 24V	125 mA
Total backplane power	4.25 W
Power dissipation, max	4.3 W
Thermal dissipation	14.66 BTU/hr
Open circuit detection time	Negative full scale reading within 5 s with any combination of lost wires, except input terminal A alone. If input terminal A is lost by itself, the module reads a positive full scale reading within 5 s
Overvoltage protection, max	24V AC/DC
Normal mode noise rejection	60 dB at 60 Hz ⁽¹⁾
Common mode noise rejection	120 dB @ 60 Hz 100 dB @ 50 Hz
Channel bandwidth	15 Hz ⁽¹⁾
Settling time	<80 ms to 5% of full scale ⁽¹⁾
Calibrated accuracy @ 25 °C	Better than 0.1% of range
Calibration interval	6 months
Offset drift	10 M Ω /°C
Gain drift with temperature, nom	50 ppm/°C
Gain drift with temperature, max	90 ppm/°C
Module error	0.54% of range
Module scan time	25 ms min floating point (ohms) 50 ms min floating point (temperature) 10 ms min integer (ohms) ⁽¹⁾
Data format	Integer mode (left justified, 2s complement) IEEE 32-bit floating point
Module conversion method	Sigma-Delta
Isolation voltage	250V (continuous), basic insulation type, input channels-to-backplane, and input channel-to-channel Routine tested at 1350V AC for 2 s
Module keying	Electronic, software configurable
Removable terminal block	1756-TBNH 1756-TBSH
RTB keying	User-defined mechanical
Slot width	1
Wire category	2 ⁽²⁾
North American temperature code	T4A
IEC temperature code	T4
Enclosure type	None (open-style)

(1) Notch filter dependent.

(2) Use this conductor category information for planning conductor routing as described in the system-level installation manual. See the Industrial Automation Wiring and Grounding Guidelines, publication [1770-4.1](#).

Environmental Specifications - 1756-IR6I

Attribute	1756-IR6I
Temperature, operating IEC 60068-2-1 (Test Ad, Operating Cold), IEC 60068-2-2 (Test Bd, Operating Dry Heat), IEC 60068-2-14 (Test Nb, Operating Thermal Shock)	0...60 °C (32...140 °F)
Temperature, surrounding air, max	60 °C (140 °F)
Temperature, storage IEC 60068-2-1 (Test Ab, Unpackaged Nonoperating Cold), IEC 60068-2-2 (Test Bb, Unpackaged Nonoperating Dry Heat), IEC 60068-2-14 (Test Na, Unpackaged Nonoperating Thermal Shock)	-40...85 °C (-40...185 °F)
Relative humidity IEC 60068-2-30 (Test Db, Unpackaged Nonoperating Damp Heat)	5...95% noncondensing
Vibration IEC 60068-2-6 (Test Fc, Operating)	2 g @ 10...500 Hz
Shock, operating IEC 60068-2-27 (Test Ea, Unpackaged Shock)	30 g
Shock, nonoperating IEC 60068-2-27 (Test Ea, Unpackaged Shock)	50 g
Emissions	CISPR 11: Group 1, Class A
ESD immunity IEC 61000-4-2	6 kV contact discharges 8 kV air discharges
Radiated RF immunity IEC 61000-4-3	10V/m with 1 kHz sine-wave 80% AM from 80...2000 MHz 10V/m with 200 Hz 50% Pulse 100% AM @ 900 MHz 10V/m with 200 Hz 50% Pulse 100% AM @ 1890 MHz 3V/m with 1 kHz sine-wave 80% AM from 2000...2700 MHz
EFT/B immunity IEC 61000-4-4	±2 kV at 5 kHz on shielded signal ports
Surge transient immunity IEC 61000-4-5	±2 kV line-earth (CM) on shielded signal ports
Conducted RF immunity IEC 61000-4-6	10V rms with 1 kHz sine-wave 80% AM from 150 kHz...80 MHz on shielded signal ports

Certifications - 1756-IR6I

Certification⁽¹⁾	1756-IR6I
UL	UL Listed Industrial Control Equipment, certified for US and Canada. See UL File E65584.
CSA	CSA Certified Process Control Equipment. See CSA File LR54689C. CSA Certified Process Control Equipment for Class I, Division 2 Group A,B,C,D Hazardous Locations. See CSA File LR69960C.
CE	European Union 2004/108/IEC EMC Directive, compliant with: <ul style="list-style-type: none"> • EN 61326-1; Meas./Control/Lab., Industrial Requirements • EN 61000-6-2; Industrial Immunity • EN 61000-6-4; Industrial Emissions • EN 61131-2; Programmable Controllers (Clause 8, Zone A & B) European Union 2006/95/EC LVD, compliant with: <ul style="list-style-type: none"> • EN 61131-2; Programmable Controllers (Clause 11)
C-Tick	Australian Radiocommunications Act, compliant with: AS/NZS CISPR 11; Industrial Emissions
Ex	European Union 94/9/EC ATEX Directive, compliant with: <ul style="list-style-type: none"> • EN 60079-15; Potentially Explosive Atmospheres, Protection "n" • EN 60079-0; General Requirements II 3 G Ex nA IIC T4 X
FM	FM Approved Equipment for use in Class I Division 2 Group A,B,C,D Hazardous Locations
TÜV	TÜV Certified for Functional Safety ⁽²⁾ : Capable of SIL 2

(1) When marked. See the Product Certification link at <http://www.ab.com> for Declarations of Conformity, Certificates, and other certification details.

(2) When used with specified firmware revisions and in accordance with application guidelines described in Using ControlLogix in SIL2 Applications Safety Reference Manual, publication [1756-RM001](#).

1756-IT6I

ControlLogix temperature sensing analog input module

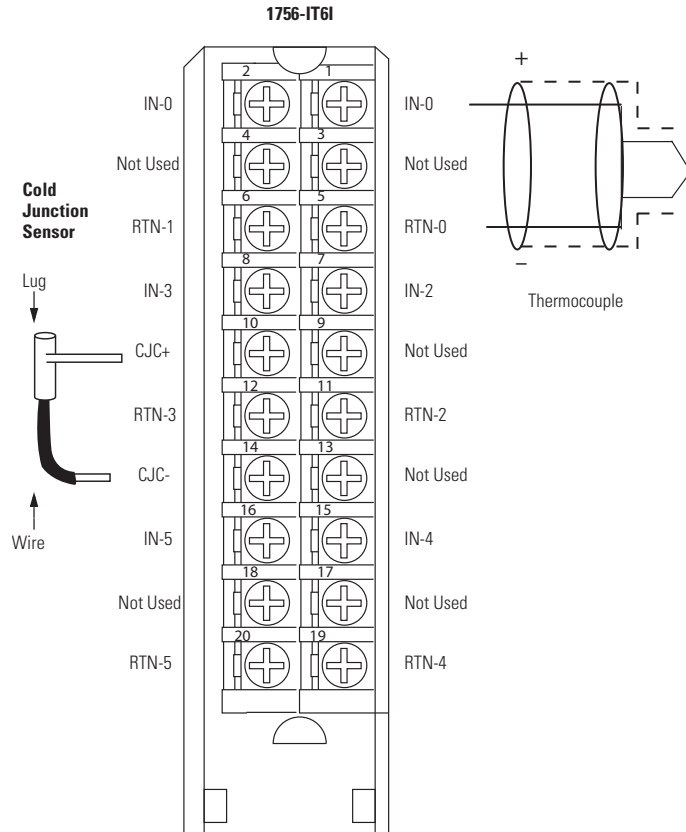

One CJC, part number 94238301, is shipped with the module.
A replacement can be ordered as RP-94238301.

Signal and User Counts - 1756-IT6I

Range	Low Signal and User Counts	High Signal and User Counts
-12...30 mV	-15.80323 mV -32768 counts	31.396 mV 32767 counts
-12...78 mV	-15.15836 mV -32768 counts	79.241 mV 32767 counts

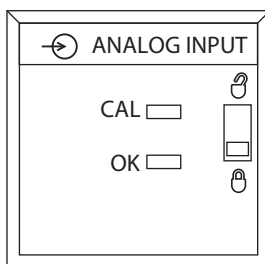

Technical Specifications - 1756-IT6I

Attribute	1756-IT6I
Inputs	6 individually isolated thermocouple 1 CJC
Input range	-12...78 mV -12...30 mV (high resolution range)
Resolution	16 bits -12...78 mV: 1.4 μ V/bit (typical) -12...30 mV: 0.7 μ V/bit (high resolution range)
Thermocouples	B, E, J, K, R, S, T, N, C

Technical Specifications - 1756-IT6I

Attribute	1756-IT6I
Thermocouple linearization	ITS-90
Current draw @ 5.1V	250 mA
Current draw @ 24V	125 mA
Total backplane power	4.3 W
Power dissipation, max	4.3 W
Thermal dissipation	14.66 BTU/hr
Input impedance	>10 M Ω
Open circuit detection time	Positive full scale reading within 2 s
Overvoltage protection, max	120V AC/DC
Normal mode noise rejection	60 dB at 60 Hz ⁽¹⁾
Common mode noise rejection	120 dB @ 60 Hz 100 dB @ 50 Hz
Channel bandwidth	15 Hz (-3 dB) ⁽¹⁾
Settling time	<80 ms to 5% of full scale ⁽¹⁾
Calibrated accuracy @ 25 °C	Better than 0.1% of range
Calibration interval	6 months
Local CJC sensor accuracy	$\pm 0.3 \dots 3.2$ °C, depending on channel
Remote CJC sensor accuracy	± 0.3 °C
Offset drift	0.5 μ V/°C
Gain drift with temperature, nom	65 ppm/°C
Gain drift with temperature, max	80 ppm/°C
Module error	0.5% of range
Module scan time	25 ms min floating point (millivolt) 50 ms min floating point (temperature) 10 ms min integer (millivolt) ⁽¹⁾
Data format	Integer mode (left justified, 2s complement) IEEE 32-bit floating point
Module conversion method	Sigma-Delta
Isolation voltage	250V (continuous), basic insulation type, input channels-to-backplane, and input channel-to-channel Routine tested at 1350V AC for 2 s
Module keying	Electronic, software configurable
Removable terminal block	1756-TBNH 1756-TBSH
RTB keying	User-defined mechanical
Slot width	1
Wire category	2 ⁽²⁾
North American temperature code	T4A
IEC temperature code	T4
Enclosure type	None (open-style)

(1) Notch filter dependent.

(2) Use this conductor category information for planning conductor routing as described in the system-level installation manual. See the Industrial Automation Wiring and Grounding Guidelines, publication [1770-4.1](#).

Thermocouple Ranges - 1756-IT6I

Attribute	1756-IT6I2	
Thermocouple temperature/millivolt input range	-12...78 mV range	-12...30 mV range
Thermocouple Type B	300...1820 °C (572...3308 °F)	Full range
Thermocouple Type C	0...2315 °C (32...4199 °F)	0...1725 °C (32...3137 °F)
Thermocouple Type E	-270...1000 °C (-454...1832 °F)	-270...415 °C (-454...779 °F)
Thermocouple Type J	-210...1200 °C (-346...2192 °F)	-210...550 °C (-346...1022 °F)
Thermocouple Type K	-270...1372 °C (-454...2502 °F)	-270...725 °C (-454...1337 °F)
Thermocouple Type N	-270...1300 °C (-454...2372 °F)	-270...840 °C (-454...1544 °F)
Thermocouple Type R	-50...1768 °C (-58...3215 °F)	Full range
Thermocouple Type S	-50...1768 °C (-58...3215 °F)	Full range
Thermocouple Type T	-270...400 °C (-454...752 °F)	Full range
Thermocouple resolution over temperature range, nom	-12...78 mV range	-12...30 mV range
Type B, R, S, C	-0.15 °C (-0.28 °F)	-0.08 °C (-0.15 °F)
Type E, J, K, T, N	-0.05 °C (-0.09 °F)	-0.03 °C (-0.05 °F)
Type D	-0.07 °C (-0.13 °F)	-0.03 °C (-0.05 °F)
Type TXK/XK (L)	-0.02 °C (-0.04 °F)	-0.01 °C (-0.02 °F)

Environmental Specifications - 1756-IT6I

Attribute	1756-IT6I
Temperature, operating IEC 60068-2-1 (Test Ad, Operating Cold), IEC 60068-2-2 (Test Bd, Operating Dry Heat), IEC 60068-2-14 (Test Nb, Operating Thermal Shock)	0...60 °C (32...140 °F)
Temperature, surrounding air, max	60 °C (140 °F)
Temperature, storage IEC 60068-2-1 (Test Ab, Unpackaged Nonoperating Cold), IEC 60068-2-2 (Test Bb, Unpackaged Nonoperating Dry Heat), IEC 60068-2-14 (Test Na, Unpackaged Nonoperating Thermal Shock)	-40...85 °C (-40...185 °F)
Relative humidity IEC 60068-2-30 (Test Db, Unpackaged Nonoperating Damp Heat)	5...95% noncondensing
Vibration IEC 60068-2-6 (Test Fc, Operating)	2 g @ 10...500 Hz
Shock, operating IEC 60068-2-27 (Test Ea, Unpackaged Shock)	30 g
Shock, nonoperating IEC 60068-2-27 (Test Ea, Unpackaged Shock)	50 g
Emissions	CISPR 11: Group 1, Class A
ESD immunity IEC 61000-4-2	6 kV contact discharges 8 kV air discharges
Radiated RF immunity IEC 61000-4-3	10V/m with 1 kHz sine-wave 80% AM from 80...2000 MHz 10V/m with 200 Hz 50% Pulse 100% AM @ 900 MHz 10V/m with 200 Hz 50% Pulse 100% AM @ 1890 MHz 3V/m with 1 kHz sine-wave 80% AM from 2000...2700 MHz
EFT/B immunity IEC 61000-4-4	±2 kV at 5 kHz on shielded signal ports
Surge transient immunity IEC 61000-4-5	±2 kV line-earth (CM) on shielded signal ports
Conducted RF immunity IEC 61000-4-6	10V rms with 1 kHz sine-wave 80% AM from 150 kHz...80 MHz on shielded signal ports

Certifications - 1756-IT6I

Certification⁽¹⁾	1756-IT6I
UL	UL Listed Industrial Control Equipment, certified for US and Canada. See UL File E65584.
CSA	CSA Certified Process Control Equipment. See CSA File LR54689C. CSA Certified Process Control Equipment for Class I, Division 2 Group A,B,C,D Hazardous Locations. See CSA File LR69960C.
CE	European Union 2004/108/IEC EMC Directive, compliant with: <ul style="list-style-type: none"> • EN 61326-1; Meas./Control/Lab., Industrial Requirements • EN 61000-6-2; Industrial Immunity • EN 61000-6-4; Industrial Emissions • EN 61131-2; Programmable Controllers (Clause 8, Zone A & B) European Union 2006/95/EC LVD, compliant with: <ul style="list-style-type: none"> • EN 61131-2; Programmable Controllers (Clause 11)
C-Tick	Australian Radiocommunications Act, compliant with: AS/NZS CISPR 11; Industrial Emissions
Ex	European Union 94/9/EC ATEX Directive, compliant with: <ul style="list-style-type: none"> • EN 60079-15; Potentially Explosive Atmospheres, Protection "n" • EN 60079-0; General Requirements II 3 G Ex nA IIC T4 X
FM	FM Approved Equipment for use in Class I Division 2 Group A,B,C,D Hazardous Locations
TÜV	TÜV Certified for Functional Safety ⁽²⁾ : Capable of SIL 2

(1) When marked. See the Product Certification link at <http://www.ab.com> for Declarations of Conformity, Certificates, and other certification details.

(2) When used with specified firmware revisions and in accordance with application guidelines described in Using ControlLogix in SIL2 Applications Safety Reference Manual, publication [1756-RM001](#).

1756-IT6I2

ControlLogix enhanced thermocouple analog input module

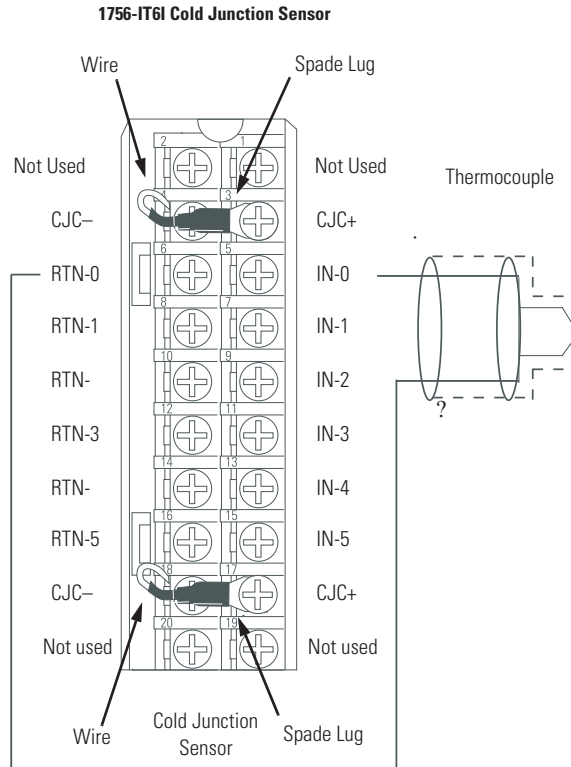

Two CJCs, part number 94286501, are shipped with the module. Replacements can be ordered as RP-94286501.

Signal and User Counts - 1756-IT6I2

Range	Low Signal and User Counts	High Signal and User Counts
-12...30 mV	-15.80323 mV -32768 counts	31.396 mV 32767 counts
-12...78 mV	-15.15836 mV -32768 counts	79.241 mV 32767 counts

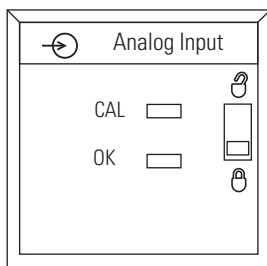

Technical Specifications - 1756-IT6I2

Attribute	1756-IT6I2
Inputs	6 individually isolated thermocouple 2 CJC
Input range	-12...78 mV (1.4 μ V per bit) -12...30 mV (0.7 μ V per bit – high resolution range)
Resolution	16 bits -12...78 mV: 1.4 μ V/bit -12...30 mV: 0.7 μ V/bit
Thermocouples	B, E, J, K, R, S, T, N, C, D, L (TXK/XK)
Thermocouple linearization	ITS-90
Current draw @ 5.1V	200 mA

Technical Specifications - 1756-IT6I2

Attribute	1756-IT6I2
Current draw @ 24V	150 mA
Total backplane power	4.6 W
Power dissipation, max	4.6 W
Thermal dissipation	15.7 BTU/hr
Input impedance	>10 M Ω
Open circuit detection time	Positive full scale reading within 2 s
Overvoltage protection, max	120V AC/DC
Normal mode noise rejection	60 dB at 60 Hz ⁽¹⁾
Common mode noise rejection	160 dB min, tested @ 600V AC/60 Hz applied with 100 Ω differential resistance
Channel bandwidth	15 Hz ⁽¹⁾
Settling time	<80 ms to 5% of full scale ⁽¹⁾
Calibrated accuracy @ 25 °C	0.05% of full range @ 25 °C (77 °F) typical Better than 0.1% of range @ 25 °C (77 °F) worst case
Calibration interval	12 months
Local CJC sensor accuracy	± 0.3 °C
Remote CJC sensor accuracy	± 0.3 °C
Offset drift	0.5 μ V/°C
Gain drift with temperature, nom	15 ppm/°C 1.4 μ V/°C for -12...78 mV 0.6 μ V/°C for -12...30 mV
Gain drift with temperature, max	25 ppm/°C 2.3 μ V/°C for -12...78 mV 1.1 μ V/°C for -12...30 mV
Module error	0.15% of range
Module scan time	25 ms min floating point (millivolt) 50 ms min floating point (temperature) 10 ms min integer (millivolt) ⁽¹⁾
Data format	Integer mode (left justified, 2s complement) IEEE 32-bit floating point
Module conversion method	Sigma-Delta
Isolation voltage	250V (continuous), basic insulation type, input channels-to-backplane, and input channel-to-channel Routine tested at 1350V AC for 2 s
Module keying	Electronic, software configurable
Removable terminal block	1756-TBNH only
RTB keying	User-defined mechanical
Slot width	1
Wire category	2 ⁽²⁾
North American temperature code	T4A
IEC temperature code	T4
Enclosure type	None (open-style)

(1) Notch filter dependent.

(2) Use this conductor category information for planning conductor routing as described in the system-level installation manual. See the Industrial Automation Wiring and Grounding Guidelines, publication [1770-4.1](#).

Thermocouple Ranges - 1756-IT6I2

Attribute	1756-IT6I2	
Thermocouple temperature/millivolt input range	-12...78 mV range	-12...30 mV range
Thermocouple Type B	300...1820 °C (572...3308 °F)	Full range
Thermocouple Type C	0...2315 °C (32...4199 °F)	0...1725 °C (32...3137 °F)
Thermocouple Type E	-270...1000 °C (-454...1832 °F)	-270...415 °C (-454...779 °F)
Thermocouple Type J	-210...1200 °C (-346...2192 °F)	-210...550 °C (-346...1022 °F)
Thermocouple Type K	-270...1372 °C (-454...2502 °F)	-270...725 °C (-454...1337 °F)
Thermocouple Type N	-270...1300 °C (-454...2372 °F)	-270...840 °C (-454...1544 °F)
Thermocouple Type R	-50...1768 °C (-58...3215 °F)	Full range
Thermocouple Type S	-50...1768 °C (-58...3215 °F)	Full range
Thermocouple Type T	-270...400 °C (-454...752 °F)	Full range
Thermocouple Type D	0...2320 °C (32...4208 °F)	0...1718 °C (32...3124 °F)
Thermocouple Type L (TXK/XK)	-200...800 °C (-328...1472 °F)	200...399 °C (392...750 °F)
Thermocouple resolution over temperature range, nom	-12...78 mV range	-12...30 mV range
Type B, R, S, C	-0.15 °C (-0.28 °F)	-0.08 °C (-0.15 °F)
Type E, J, K, T, N	-0.05 °C (-0.09 °F)	-0.03 °C (-0.05 °F)
Type D	-0.07 °C (-0.13 °F)	-0.03 °C (-0.05 °F)
Type TXK/XK (L)	-0.02 °C (-0.04 °F)	-0.01 °C (-0.02 °F)

Environmental Specifications - 1756-IT6I2

Attribute	1756-IT6I2
Temperature, operating IEC 60068-2-1 (Test Ad, Operating Cold), IEC 60068-2-2 (Test Bd, Operating Dry Heat), IEC 60068-2-14 (Test Nb, Operating Thermal Shock)	0...60 °C (32...140 °F)
Temperature, surrounding air, max	60 °C (140 °F)
Temperature, storage IEC 60068-2-1 (Test Ab, Unpackaged Nonoperating Cold), IEC 60068-2-2 (Test Bb, Unpackaged Nonoperating Dry Heat), IEC 60068-2-14 (Test Na, Unpackaged Nonoperating Thermal Shock)	-40...85 °C (-40...185 °F)
Relative humidity IEC 60068-2-30 (Test Db, Unpackaged Nonoperating Damp Heat)	5...95% noncondensing
Vibration IEC 60068-2-6 (Test Fc, Operating)	2 g @ 10...500 Hz
Shock, operating IEC 60068-2-27 (Test Ea, Unpackaged Shock)	30 g
Shock, nonoperating IEC 60068-2-27 (Test Ea, Unpackaged Shock)	50 g
Emissions	CISPR 11: Group 1, Class A
ESD immunity IEC 61000-4-2	6 kV contact discharges 8 kV air discharges
Radiated RF immunity IEC 61000-4-3	10V/m with 1 kHz sine-wave 80% AM from 80...2000 MHz 10V/m with 200 Hz 50% Pulse 100% AM @ 900 MHz 10V/m with 200 Hz 50% Pulse 100% AM @ 1890 MHz 3V/m with 1 kHz sine-wave 80% AM from 2000...2700 MHz

Environmental Specifications - 1756-IT6I2

Attribute	1756-IT6I2
EFT/B immunity IEC 61000-4-4	±2 kV at 5 kHz on shielded signal ports
Surge transient immunity IEC 61000-4-5	±2 kV line-earth (CM) on shielded signal ports
Conducted RF immunity IEC 61000-4-6	10V rms with 1 kHz sine-wave 80% AM from 150 kHz...80 MHz on shielded signal ports

Certifications - 1756-IT6I2

Certification ⁽¹⁾	1756-IT6I2
UL	UL Listed Industrial Control Equipment, certified for US and Canada. See UL File E65584.
CSA	CSA Certified Process Control Equipment. See CSA File LR54689C. CSA Certified Process Control Equipment for Class I, Division 2 Group A,B,C,D Hazardous Locations. See CSA File LR69960C.
CE	European Union 2004/108/IEC EMC Directive, compliant with: <ul style="list-style-type: none"> • EN 61326-1; Meas./Control/Lab., Industrial Requirements • EN 61000-6-2; Industrial Immunity • EN 61000-6-4; Industrial Emissions • EN 61131-2; Programmable Controllers (Clause 8, Zone A & B) European Union 2006/95/EC LVD, compliant with: <ul style="list-style-type: none"> • EN 61131-2; Programmable Controllers (Clause 11)
C-Tick	Australian Radiocommunications Act, compliant with: AS/NZS CISPR 11; Industrial Emissions
Ex	European Union 94/9/EC ATEX Directive, compliant with: <ul style="list-style-type: none"> • EN 60079-15; Potentially Explosive Atmospheres, Protection "n" • EN 60079-0; General Requirements II 3 G Ex nA IIC T4 X
FM	FM Approved Equipment for use in Class I Division 2 Group A,B,C,D Hazardous Locations
TÜV	TÜV Certified for Functional Safety ⁽²⁾ : Capable of SIL 2

(1) When marked. See the Product Certification link at <http://www.ab.com> for Declarations of Conformity, Certificates, and other certification details.

(2) When used with specified firmware revisions and in accordance with application guidelines described in Using ControlLogix in SIL2 Applications Safety Reference Manual, publication [1756-RM001](#).

1756-IV16

ControlLogix DC (10...30V) sourcing input module

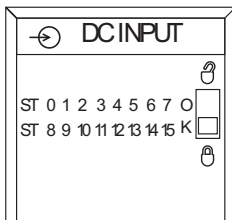
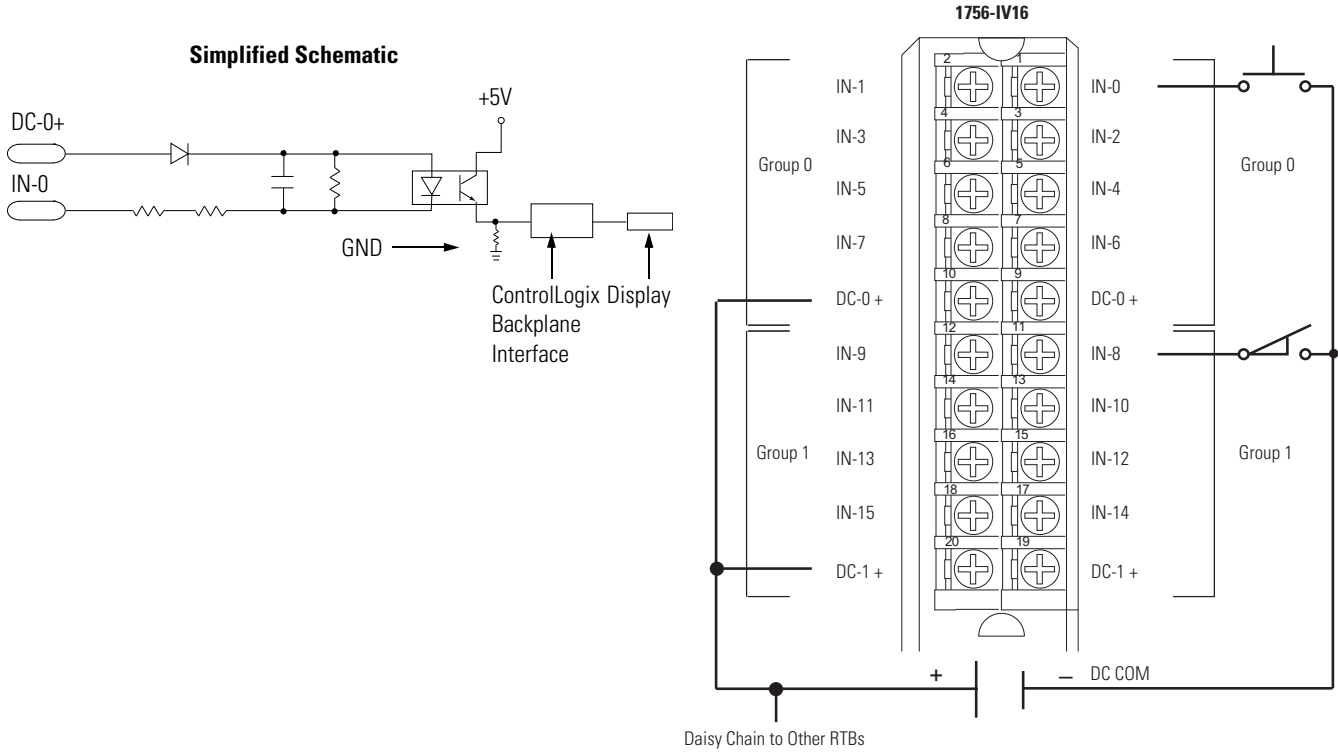

Technical Specifications - 1756-IV16

Attribute	1756-IV16
Inputs	16 (8 points/group)
Voltage category	12/24V DC source
Operating voltage range	10...30V DC
Input voltage, nom	24V DC
Input delay time OFF to ON	Hardware delay: 280 μ s nom/1 ms max + filter time User-selectable filter time: 0, 1, or 2 ms
ON to OFF	Hardware delay: 540 μ s nom/2 ms max + filter time User-selectable filter time: 0, 1, 2, 9, or 18 ms
Current draw @ 5.1V	110 mA
Current draw @ 24V	2 mA
Total backplane power	0.61 W
Power dissipation, max	5.41 W @ 60 °C (140 °F)
Thermal dissipation	18.47 BTU/hr
Off-state voltage, max	5V DC
Off-state current, max	1.5 mA
On-state current, min	2 mA @ 10V DC
On-state current, max	10 mA @ 30V DC

Technical Specifications - 1756-IV16

Attribute	1756-IV16
Inrush current, max	250 mA
Input impedance, max	3.2 k Ω @ 30V DC
Cyclic update time	200 μ s...750 ms
Change of state	Software configurable
Timestamp of inputs	\pm 200 μ s
Isolation voltage	250V (continuous), basic insulation type, inputs-to-backplane, and input group-to-group No isolation between individual group inputs Routine tested @ 1350V AC for 2 s
Module keying	Electronic, software configurable
Removable terminal block housing	1756-TBNH 1756-TBSH
RTB keying	User-defined mechanical
Slot width	1
Wire category	1 ⁽¹⁾
North American temperature code	T4A
IEC temperature code	T4
Enclosure type	None (open-style)
Reverse polarity protection	Yes

(1) Use this conductor category information for planning conductor routing as described in the system-level installation manual. See the Industrial Automation Wiring and Grounding Guidelines, publication [1770-4.1](#).

Environmental Specifications - 1756-IV16

Attribute	1756-IV16
Temperature, operating IEC 60068-2-1 (Test Ad, Operating Cold), IEC 60068-2-2 (Test Bd, Operating Dry Heat), IEC 60068-2-14 (Test Nb, Operating Thermal Shock)	0...60 °C (32...140 °F)
Temperature, surrounding air, max	60 °C (140 °F)
Temperature, storage IEC 60068-2-1 (Test Ab, Unpackaged Nonoperating Cold), IEC 60068-2-2 (Test Bb, Unpackaged Nonoperating Dry Heat), IEC 60068-2-14 (Test Na, Unpackaged Nonoperating Thermal Shock)	-40...85 °C (-40...185 °F)
Relative humidity IEC 60068-2-30 (Test Db, Unpackaged Nonoperating Damp Heat)	5...95% noncondensing
Vibration IEC 60068-2-6 (Test Fc, Operating)	2 g @ 10...500 Hz
Shock, operating IEC 60068-2-27 (Test Ea, Unpackaged Shock)	30 g
Shock, nonoperating IEC 60068-2-27 (Test Ea, Unpackaged Shock)	50 g
Emissions	CISPR 11: Group 1, Class A
ESD immunity IEC 61000-4-2	6 kV contact discharges 8 kV air discharges
Radiated RF immunity IEC 61000-4-3	10V/m with 1 kHz sine-wave 80% AM from 80...2000 MHz 10V/m with 200 Hz 50% Pulse 100% AM @ 900 MHz 10V/m with 200 Hz 50% Pulse 100% AM @ 1890 MHz 3V/m with 1 kHz sine-wave 80% AM from 2000...2700 MHz

Environmental Specifications - 1756-IV16

Attribute	1756-IV16
EFT/B immunity IEC 61000-4-4	±4 kV at 5 kHz on signal ports
Surge transient immunity IEC 61000-4-5	±1 kV line-line (DM) and ±2 kV line-earth (CM) on signal ports
Conducted RF immunity IEC 61000-4-6	10V rms with 1 kHz sine-wave 80% AM from 150 kHz...80 MHz

Certifications - 1756-IV16

Certification ⁽¹⁾	1756-IV16
UL	UL Listed Industrial Control Equipment, certified for US and Canada. See UL File E65584.
CSA	CSA Certified Process Control Equipment. See CSA File LR54689C. CSA Certified Process Control Equipment for Class I, Division 2 Group A,B,C,D Hazardous Locations. See CSA File LR69960C.
CE	European Union 2004/108/IEC EMC Directive, compliant with: <ul style="list-style-type: none"> • EN 61326-1; Meas./Control/Lab., Industrial Requirements • EN 61000-6-2; Industrial Immunity • EN 61000-6-4; Industrial Emissions • EN 61131-2; Programmable Controllers (Clause 8, Zone A & B) European Union 2006/95/EC LVD, compliant with: <ul style="list-style-type: none"> • EN 61131-2; Programmable Controllers (Clause 11)
C-Tick	Australian Radiocommunications Act, compliant with: AS/NZS CISPR 11; Industrial Emissions
Ex	European Union 94/9/EC ATEX Directive, compliant with: <ul style="list-style-type: none"> • EN 60079-15; Potentially Explosive Atmospheres, Protection "n" • EN 60079-0; General Requirements II 3 G Ex nA IIC T4 X
FM	FM Approved Equipment for use in Class I Division 2 Group A,B,C,D Hazardous Locations

(1) When marked. See the Product Certification link at <http://www.ab.com> for Declarations of Conformity, Certificates, and other certification details.

1756-IV32

ControlLogix DC (10...30V) sourcing input module

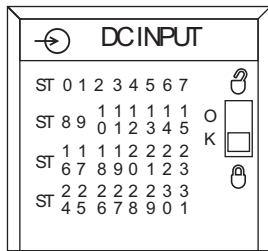
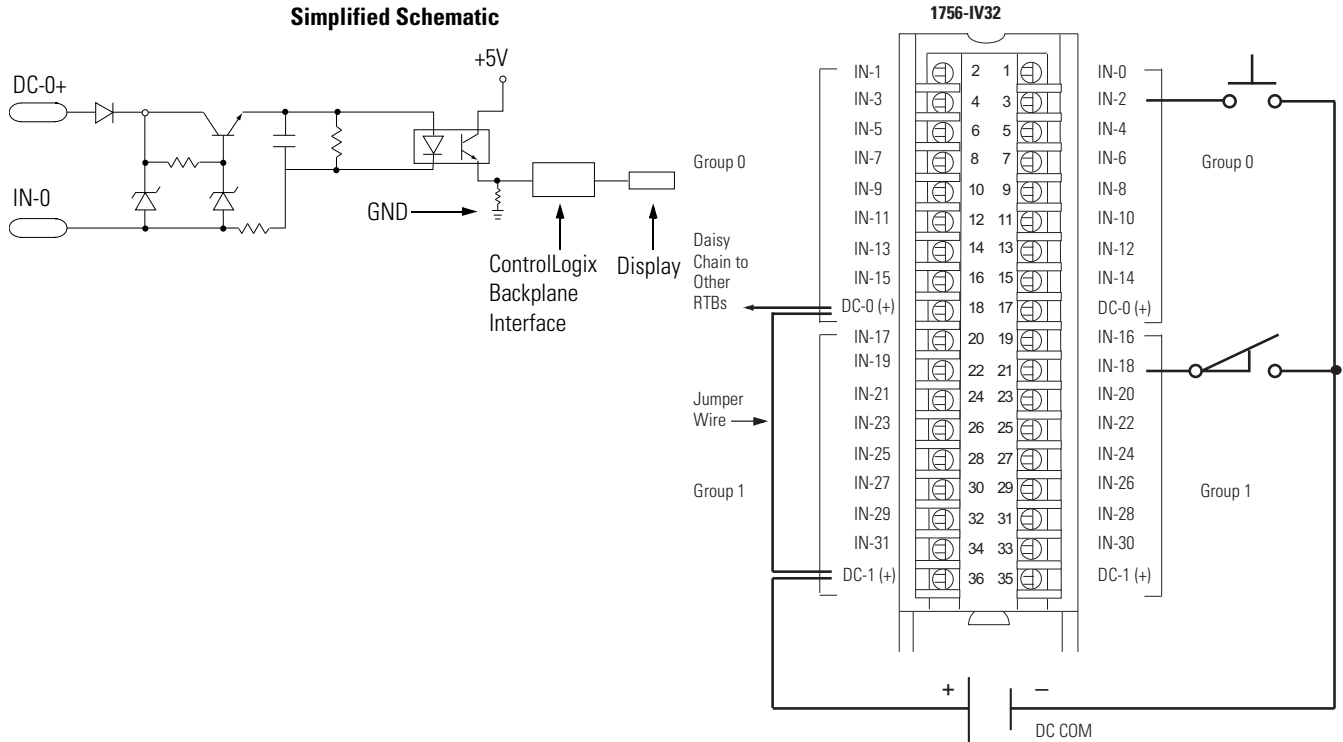

Technical Specifications - 1756-IV32

Attribute	1756-IV32
Inputs	32 (16 points/group)
Voltage category	12/24V DC source
Operating voltage range	10...30V DC
Input voltage, nom	24V DC
Input delay time OFF to ON	Hardware delay: 350 μ s nom/1 ms max + filter time User-selectable filter time: 0, 1, or 2 ms
ON to OFF	Hardware delay: 540 μ s nom/2 ms max + filter time User-selectable filter time: 0, 1, 2, 9, or 18 ms
Current draw @ 5.1V	120 mA
Current draw @ 24V	2 mA
Total backplane power	0.66 W
Power dissipation, max	4.1 W @ 60 °C (140 °F)
Thermal dissipation	14 BTU/hr @ 60 °C (140 °F)
Off-state voltage, max	5V
Off-state current, max	1.5 mA
On-state current, min	2 mA @ 10V DC
On-state current, max	3.5 mA @ 30V DC
Inrush current, max	250 mA (decaying to <37% in 22 ms, without activation)

Technical Specifications - 1756-IV32

Attribute	1756-IV32
Input impedance, max	8.6 k Ω @ 30V DC
Cyclic update time	200 μ s...750 ms
Change of state	Software configurable
Timestamp of inputs	\pm 200 μ s
Isolation voltage	250V (continuous), basic insulation type, inputs-to-backplane, and input group-to-group No isolation between individual group inputs Routine tested @ 1350V AC for 2 s
Module keying	Electronic, software configurable
Removable terminal block	1756-TBCH 1756-TBS6H
RTB keying	User-defined mechanical
Slot width	1
Wire category	1 - on signal ports ⁽¹⁾
North American temperature code	T4A
IEC temperature code	T4
Enclosure type	None (open-style)
Reverse polarity protection	Yes

(1) Use this conductor category information for planning conductor routing as described in the system-level installation manual. See the Industrial Automation Wiring and Grounding Guidelines, publication [1770-4.1](#).

Environmental Specifications - 1756-IV32

Attribute	1756-IV32
Temperature, operating IEC 60068-2-1 (Test Ad, Operating Cold), IEC 60068-2-2 (Test Bd, Operating Dry Heat), IEC 60068-2-14 (Test Nb, Operating Thermal Shock)	0...60 °C (32...140 °F)
Temperature, surrounding air, max	60 °C (140 °F)
Temperature, storage IEC 60068-2-1 (Test Ab, Unpackaged Nonoperating Cold), IEC 60068-2-2 (Test Bb, Unpackaged Nonoperating Dry Heat), IEC 60068-2-14 (Test Na, Unpackaged Nonoperating Thermal Shock)	-40...85 °C (-40...185 °F)
Relative humidity IEC 60068-2-30 (Test Db, Unpackaged Nonoperating Damp Heat)	5...95% noncondensing
Vibration IEC 60068-2-6 (Test Fc, Operating)	2 g @ 10...500 Hz
Shock, operating IEC 60068-2-27 (Test Ea, Unpackaged Shock)	30 g
Shock, nonoperating IEC 60068-2-27 (Test Ea, Unpackaged Shock)	50 g
Emissions	CISPR 11: Group 1, Class A
ESD immunity IEC 61000-4-2	6 kV contact discharges 8 kV air discharges
Radiated RF immunity IEC 61000-4-3	10V/m with 1k Hz sine-wave 80% AM from 80...2000 MHz 10V/m with 200 Hz 50% Pulse 100% AM @ 900 MHz 10V/m with 200 Hz 50% Pulse 100% AM @ 1890 MHz 3V/m with 1 kHz sine-wave 80% AM from 2000...2700 MHz

Environmental Specifications - 1756-IV32

Attribute	1756-IV32
EFT/B immunity IEC 61000-4-4	±4 kV at 5 kHz on signal ports
Surge transient immunity IEC 61000-4-5	±1 kV line-line (DM) and ±2 kV line-earth (CM) on signal ports
Conducted RF immunity IEC 61000-4-6	10V rms with 1 kHz sine-wave 80% AM from 150 kHz...80 MHz

Certifications - 1756-IV32

Certification ⁽¹⁾	1756-IV32
UL	UL Listed Industrial Control Equipment, certified for US and Canada. See UL File E65584.
CSA	CSA Certified Process Control Equipment. See CSA File LR54689C. CSA Certified Process Control Equipment for Class I, Division 2 Group A,B,C,D Hazardous Locations. See CSA File LR69960C.
CE	European Union 2004/108/IEC EMC Directive, compliant with: <ul style="list-style-type: none"> • EN 61326-1; Meas./Control/Lab., Industrial Requirements • EN 61000-6-2; Industrial Immunity • EN 61000-6-4; Industrial Emissions • EN 61131-2; Programmable Controllers (Clause 8, Zone A & B) European Union 2006/95/EC LVD, compliant with: <ul style="list-style-type: none"> • EN 61131-2; Programmable Controllers (Clause 11)
C-Tick	Australian Radiocommunications Act, compliant with: AS/NZS CISPR 11; Industrial Emissions
Ex	European Union 94/9/EC ATEX Directive, compliant with: <ul style="list-style-type: none"> • EN 60079-15; Potentially Explosive Atmospheres, Protection "n" • EN 60079-0; General Requirements II 3 G Ex nA IIC T4 X
FM	FM Approved Equipment for use in Class I Division 2 Group A,B,C,D Hazardous Locations

(1) When marked. See the Product Certification link at <http://www.ab.com> for Declarations of Conformity, Certificates, and other certification details.

1756-0A8

ControlLogix AC (74...265V) output module

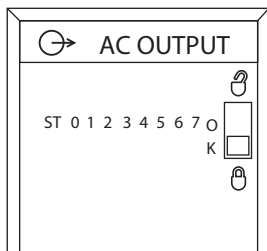
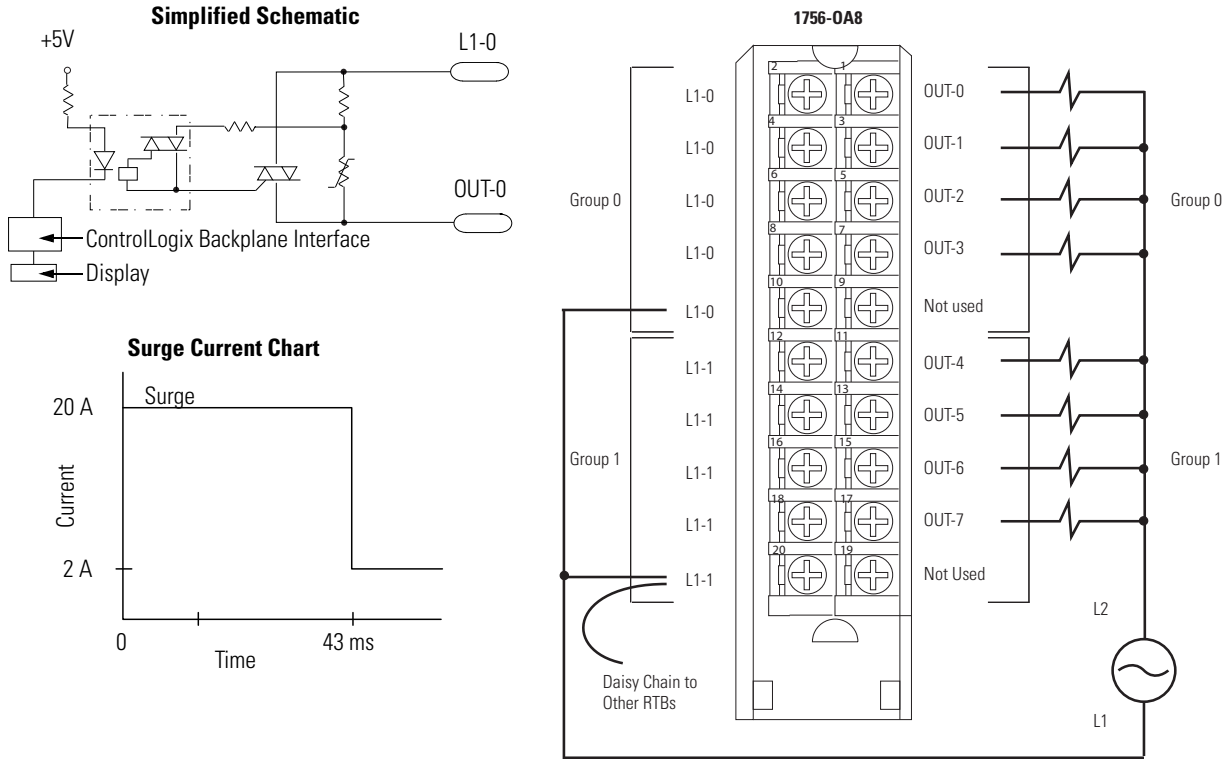

Technical Specifications - 1756-0A8

Attribute	1756-0A8
Outputs	8 (4 points/group)
Pilot duty	2 A
Voltage category	120/240V AC
Operating voltage range	74...265V AC 47...63 Hz
Output delay time	
OFF to ON	9.3 ms @ 60 Hz 11 ms @ 50 Hz
ON to OFF	9.3 ms @ 60 Hz 11 ms @ 50 Hz
Current draw @ 5.1V	200 mA
Current draw @ 24V	2 mA
Total backplane power	1.07 W
Power dissipation, max	5.1 W @ 60 °C (140 °F)
Thermal dissipation	17.39 BTU/hr
Off-state leakage current, max	3 mA per point
On-state voltage drop, max	1.5V peak @ 2 A 6V peak @ <50 mA

Technical Specifications - 1756-OA8

Attribute	1756-OA8
Current per point, max	2 A @ 60 °C (140 °F) linear derating
Current per module, max	5 A @ 30 °C (86 °F) linear derating 4 A @ 60 °C (140 °F) linear derating
Surge current per point	20 A for 43 ms per point, repeatable every 2 s @ 60 °C (140 °F)
Load current, min	10 mA per point
Commutating voltage	4V/μs for loads > 50 mA 0.2V/μs for loads < 50 mA ⁽¹⁾
Scheduled outputs	Synchronization within 16.7 s max, reference to the Coordinated System Time
Fault states per point	Hold last state, on or off (off is default)
States in Program mode per point	Hold last state, on or off (off is default)
Isolation voltage	250V (continuous), basic insulation type, outputs-to-backplane, and output group-to-group No isolation between individual group outputs Routine tested @ 1350V AC for 2 s
Inhibit voltage, max	Zero crossing 60V peak
Module keying	Electronic, software configurable
Fusing	Not protected. A fused IFM is recommended to protect outputs
Removable terminal block	1756-TBNH 1756-TBSH
RTB keying	User-defined mechanical
Slot width	1
Wire category	1 ⁽²⁾
North American temperature code	T4A
Enclosure type	None (open style)

(1) The commutating dv/dt of the output voltage (OUTPUT to L2) should not exceed 0.2V/ms for loads under 50 mA. The commutating dv/dt rating of the module for loads 50...500 mA (OUTPUT to L2) is 4V/ms maximum. If the commutating dv/dt rating of the TRIAC is exceeded, the TRIAC could latch on. If the commutating dv/dt rating is exceeded in the 10...50 mA range, a resistor may be added across the output and L2. The purpose of this resistor is to increase the total output current to 50 mA ($I=V/R$). At 50 mA and above, the module has a higher commutating dv/dt rating. When adding a resistor for the output to L2, be sure it is rated for the power that it will dissipate ($P=V^2/R$). If the commutating dv/dt rating is exceeded in the 50...500 mA range, the L1 AC waveform could be at fault. Be sure the waveform is a good sinusoid, void of any anomalies such as distorted or flattened sections.

(2) Use this conductor category information for planning conductor routing as described in the system-level installation manual. See the Industrial Automation Wiring and Grounding Guidelines, publication [1770-4.1](#).

Environmental Specifications - 1756-OA8

Attribute	1756-OA8
Temperature, operating IEC 60068-2-1 (Test Ad, Operating Cold), IEC 60068-2-2 (Test Bd, Operating Dry Heat), IEC 60068-2-14 (Test Nb, Operating Thermal Shock)	0...60 °C (32...140 °F)
Temperature, surrounding air, max	60 °C (140 °F)
Temperature, storage IEC 60068-2-1 (Test Ab, Unpackaged Nonoperating Cold), IEC 60068-2-2 (Test Bb, Unpackaged Nonoperating Dry Heat), IEC 60068-2-14 (Test Na, Unpackaged Nonoperating Thermal Shock)	-40...85 °C (-40...185 °F)
Relative humidity IEC 60068-2-30 (Test Db, Unpackaged Nonoperating Damp Heat)	5...95% noncondensing
Vibration IEC 60068-2-6 (Test Fc, Operating)	2 g @ 10...500 Hz
Shock, operating IEC 60068-2-27 (Test Ea, Unpackaged Shock)	30 g
Shock, nonoperating IEC 60068-2-27 (Test Ea, Unpackaged Shock)	50 g
Emissions	CISPR 11: Group 1, Class A
ESD immunity IEC 61000-4-2	6 kV contact discharges 8k V air discharges
Radiated RF immunity IEC 61000-4-3	10V/m with 1 kHz sine-wave 80% AM from 80... 2000 MHz 10V/m with 200 Hz 50% Pulse 100% AM @ 900 MHz 10V/m with 200 Hz 50% Pulse 100% AM @ 1890 MHz 3V/m with 1 kHz sine-wave 80% AM from 2000...2700 MHz
EFT/B immunity IEC 61000-4-4	±4 kV at 5 kHz on signal ports
Surge transient immunity IEC 61000-4-5	±1 kV line-line (DM) and ±2 kV line-earth (CM) on signal ports
Conducted RF immunity IEC 61000-4-6	10V rms with 1 kHz sine-wave 80% AM from 150 kHz...80 MHz

Certifications - 1756-OA8

Certification ⁽¹⁾	1756-OA8
UL	UL Listed Industrial Control Equipment, certified for US and Canada. See UL File E65584.
CSA	CSA Certified Process Control Equipment. See CSA File LR54689C. CSA Certified Process Control Equipment for Class I, Division 2 Group A,B,C,D Hazardous Locations. See CSA File LR69960C.
CE	European Union 2004/108/IEC EMC Directive, compliant with: <ul style="list-style-type: none"> • EN 61326-1; Meas./Control/Lab., Industrial Requirements • EN 61000-6-2; Industrial Immunity • EN 61000-6-4; Industrial Emissions • EN 61131-2; Programmable Controllers (Clause 8, Zone A & B) European Union 2006/95/EC LVD, compliant with: <ul style="list-style-type: none"> • EN 61131-2; Programmable Controllers
C-Tick	Australian Radiocommunications Act, compliant with: AS/NZS CISPR 11; Industrial Emissions
FM	FM Approved Equipment for use in Class I Division 2 Group A,B,C,D Hazardous Locations

(1) When marked. See the Product Certification link at <http://www.ab.com> for Declarations of Conformity, Certificates, and other certification details.

1756-0A8D

ControlLogix AC (74...132V) diagnostic output module

Simplified Schematic

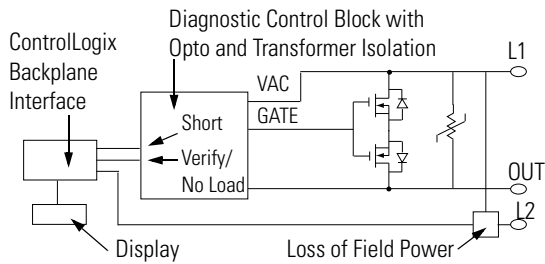

Surge Current Chart

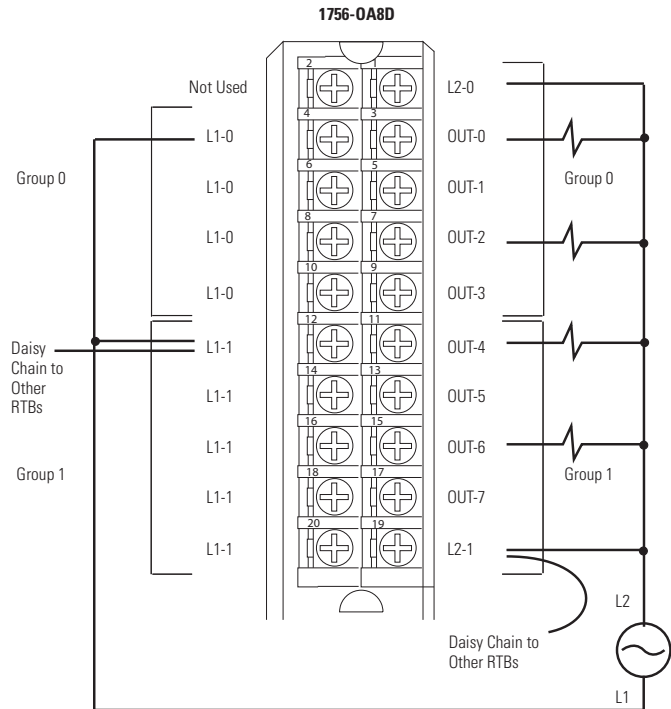
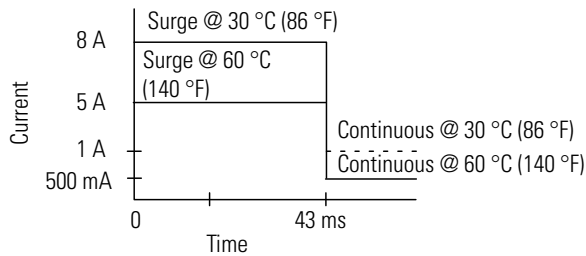

Diagnostic Specifications - 1756-0A8D

Attribute	1756-0A8D
Short trip, min	12 A for 500 μ s
No load	Off-state detection only
Output verification	On-state detection only
Pulse test	Configurable maximum width and max time delay from zero cross
Field power loss (zero cross)	Detects at 25V peak min (firmware phase locked loop)
Time stamp of diagnostics	\pm 1 ms

Technical Specifications - 1756-0A8D

Attribute	1756-0A8D
Outputs	8 diagnostic, electronic fusing (4 points/group)
Voltage category	120V AC
Operating voltage range	74...132V AC 47...63 Hz

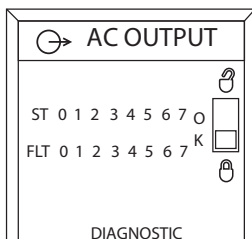

Technical Specifications - 1756-0A8D

Attribute	1756-0A8D
Output delay time OFF to ON	9.3 ms @ 60 Hz 11 ms @ 50 Hz
ON to OFF	9.3 ms @ 60 Hz 11 ms @ 50 Hz
Current draw @ 5.1V	175 mA
Current draw @ 24V	250 mA
Total backplane power	6.89 W
Power dissipation, max	5.3 W @ 60 °C (140 °F)
Thermal dissipation	18.0 BTU/hr
Off-state leakage current, max	3 mA per point
On-state voltage drop, max	2.5V peak @ 0.5 A 3V peak @ 1 A
Current per point, max	1 A @ 30 °C (86 °F) linear derating 0.5 A @ 60 °C (140 °F) linear derating
Current per module, max	8 A @ 30 °C (86 °F) linear derating 4 A @ 60 °C (140 °F) linear derating
Surge current per point	8 A for 43 ms per point, repeatable every 2 s @ 30 °C (86 °F) 5 A for 43 ms per point, repeatable every 1 s @ 60 °C (140 °F)
Load current, min	10 mA per point
Scheduled outputs	Synchronization within 16.7 s max, reference to the Coordinated System Time
Fault states per point	Hold last state, on or off (off is default)
States in Program mode per point	Hold last state, on or off (off is default)
Isolation voltage	125V (continuous), basic insulation type, outputs-to-backplane, and output group-to-group No isolation between individual group outputs Routine tested @ 1200V AC for 2 s
Inhibit voltage, max	Zero crossing 25V peak
Module keying	Electronic, software configurable
Fusing	Electronically fused per point
Removable terminal block	1756-TBNH 1756-TBSH
RTB keying	User-defined mechanical
Slot width	1
Wire category	1 ⁽¹⁾
North American temperature code	T4A
Enclosure type	None (open style)

(1) Use this conductor category information for planning conductor routing as described in the system-level installation manual. See the Industrial Automation Wiring and Grounding Guidelines, publication [1770-4.1](#).

Environmental Specifications - 1756-0A8D

Attribute	1756-0A8D
Temperature, operating IEC 60068-2-1 (Test Ad, Operating Cold), IEC 60068-2-2 (Test Bd, Operating Dry Heat), IEC 60068-2-14 (Test Nb, Operating Thermal Shock)	0...60 °C (32...140 °F)
Temperature, surrounding air, max	60 °C (140 °F)
Temperature, storage IEC 60068-2-1 (Test Ab, Unpackaged Nonoperating Cold), IEC 60068-2-2 (Test Bb, Unpackaged Nonoperating Dry Heat), IEC 60068-2-14 (Test Na, Unpackaged Nonoperating Thermal Shock)	-40...85 °C (-40...185 °F)
Relative humidity IEC 60068-2-30 (Test Db, Unpackaged Nonoperating Damp Heat)	5...95% noncondensing
Vibration IEC 60068-2-6 (Test Fc, Operating)	2 g @ 10...500 Hz
Shock, operating IEC 60068-2-27 (Test Ea, Unpackaged Shock)	30 g
Shock, nonoperating IEC 60068-2-27 (Test Ea, Unpackaged Shock)	50 g
Emissions	CISPR 11: Group 1, Class A
ESD immunity IEC 61000-4-2	6 kV contact discharges 8 kV air discharges
Radiated RF immunity IEC 61000-4-3	10V/m with 1 kHz sine-wave 80% AM from 80...2000 MHz 10V/m with 200 Hz 50% Pulse 100% AM @ 900 MHz 10V/m with 200 Hz 50% Pulse 100% AM @ 1890 MHz 3V/m with 1 kHz sine-wave 80% AM from 2000...2700 MHz
EFT/B immunity IEC 61000-4-4	±4 kV at 5 kHz on signal ports
Surge transient immunity IEC 61000-4-5	±1 kV line-line (DM) and ±2 kV line-earth (CM) on signal ports
Conducted RF immunity IEC 61000-4-6	10V rms with 1 kHz sine-wave 80% AM from 150 kHz...80 MHz

Certifications - 1756-0A8D

Certification ⁽¹⁾	1756-0A8D
UL	UL Listed Industrial Control Equipment, certified for US and Canada. See UL File E65584.
CSA	CSA Certified Process Control Equipment. See CSA File LR54689C. CSA Certified Process Control Equipment for Class I, Division 2 Group A,B,C,D Hazardous Locations. See CSA File LR69960C.
CE	European Union 2004/108/IEC EMC Directive, compliant with: <ul style="list-style-type: none"> EN 61326-1; Meas./Control/Lab., Industrial Requirements EN 61000-6-2; Industrial Immunity EN 61000-6-4; Industrial Emissions EN 61131-2; Programmable Controllers (Clause 8, Zone A & B) European Union 2006/95/EC LVD, compliant with: <ul style="list-style-type: none"> EN 61131-2; Programmable Controllers
C-Tick	Australian Radiocommunications Act, compliant with: AS/NZS CISPR 11; Industrial Emissions
FM	FM Approved Equipment for use in Class I Division 2 Group A,B,C,D Hazardous Locations
TÜV	TÜV Certified for Functional Safety ⁽²⁾ : Capable of SIL 2

(1) When marked. See the Product Certification link at <http://www.ab.com> for Declarations of Conformity, Certificates, and other certification details.(2) When used with specified firmware revisions and in accordance with application guidelines described in Using ControlLogix in SIL2 Applications Safety Reference Manual, publication [1756-RM001](#).

1756-0A8E

ControlLogix AC (74...132V) electronically-fused output module

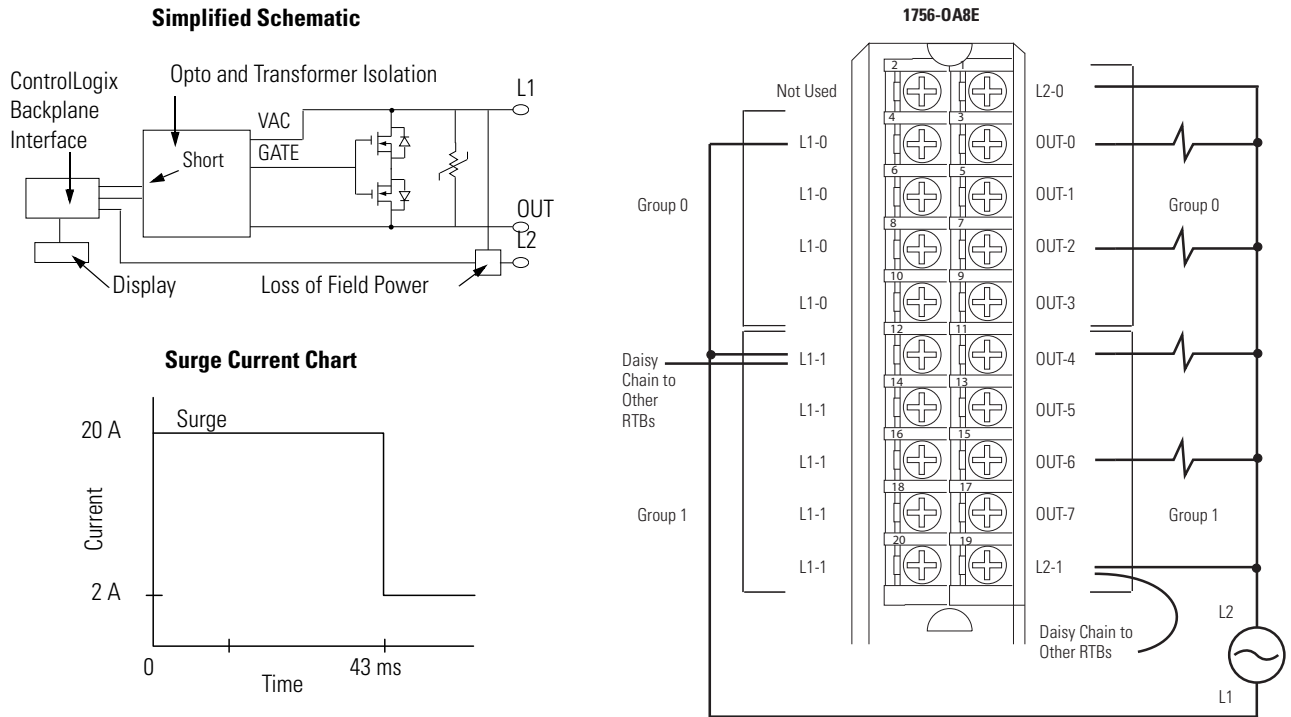

Diagnostic Specifications - 1756-0A8E

Attribute	1756-0A8E
Short trip, min	>20 A for 100 ms
Field power loss (zero cross)	Detects at 25V peak min (firmware phase locked loop)
Time stamp of diagnostics	±1 ms

Technical Specifications - 1756-0A8E

Attribute	1756-0A8E
Outputs	8 electronic fusing (4 points/group)
Pilot duty	2 A
Voltage category	120V AC
Operating voltage range	74...132V AC 47...63 Hz
Output delay time	OFF to ON 9.3 ms @ 60 Hz 11 ms @ 50 Hz
	ON to OFF 9.3 ms @ 60 Hz 11 ms @ 50 Hz
Current draw @ 5.1V	200 mA
Current draw @ 24V	250 mA

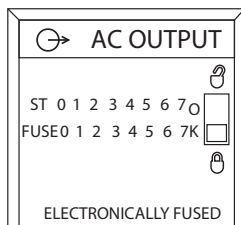

Technical Specifications - 1756-OA8E

Attribute	1756-OA8E
Total backplane power	7.02 W
Power dissipation, max	5.5 W @ 60 °C (140 °F)
Thermal dissipation	18.76 BTU/hr
Off-state leakage current, max	3 mA per point
On-state voltage drop, max	4V peak @ 2 A
Current per point, max	2 A @ 60 °C (140 °F)
Current per group, max	4 A @ 30 °C (86 °F) linear derating 2 A @ 60 °C (140 °F) linear derating
Current per module, max	8 A @ 30 °C (86 °F) linear derating 4 A @ 60 °C (140 °F) linear derating
Surge current per point	20 A for 43 ms per point, repeatable every 2 s @ 60 °C (140 °F)
Load current, min	10 mA per point
Scheduled outputs	Synchronization within 16.7 s max, reference to the Coordinated System Time
Fault states per point	Hold last state, on or off (off is default)
States in Program mode per point	Hold last state, on or off (off is default)
Isolation voltage	125V (continuous), basic insulation type, outputs-to-backplane, and output group-to-group No isolation between individual group outputs Routine tested @ 1200V AC for 2 s
Inhibit voltage, max	Zero crossing 25V peak
Module keying	Electronic, software configurable
Fusing	Electronically fused per point
Removable terminal block	1756-TBNH 1756-TBSH
RTB keying	User-defined mechanical
Slot width	1
Wire category	1 ⁽¹⁾
North American temperature code	T4A
Enclosure type	None (open style)

(1) Use this conductor category information for planning conductor routing as described in the system-level installation manual. See the Industrial Automation Wiring and Grounding Guidelines, publication [1770-4.1](#).

Environmental Specifications - 1756-0A8E

Attribute	1756-0A8E
Temperature, operating IEC 60068-2-1 (Test Ad, Operating Cold), IEC 60068-2-2 (Test Bd, Operating Dry Heat), IEC 60068-2-14 (Test Nb, Operating Thermal Shock)	0...60 °C (32...140 °F)
Temperature, surrounding air, max	60 °C (140 °F)
Temperature, storage IEC 60068-2-1 (Test Ab, Unpackaged Nonoperating Cold), IEC 60068-2-2 (Test Bb, Unpackaged Nonoperating Dry Heat), IEC 60068-2-14 (Test Na, Unpackaged Nonoperating Thermal Shock)	-40...85 °C (-40...185 °F)
Relative humidity IEC 60068-2-30 (Test Db, Unpackaged Nonoperating Damp Heat)	5...95% noncondensing
Vibration IEC 60068-2-6 (Test Fc, Operating)	2 g @ 10...500 Hz
Shock, operating IEC 60068-2-27 (Test Ea, Unpackaged Shock)	30 g
Shock, nonoperating IEC 60068-2-27 (Test Ea, Unpackaged Shock)	50 g
Emissions	CISPR 11: Group 1, Class A
ESD immunity IEC 61000-4-2	6 kV contact discharges 8 kV air discharges
Radiated RF immunity IEC 61000-4-3	10V/m with 1 kHz sine-wave 80% AM from 80... 2000 MHz 10V/m with 200 Hz 50% Pulse 100% AM @ 900 MHz 10V/m with 200 Hz 50% Pulse 100% AM @ 1890 MHz 3V/m with 1 kHz sine-wave 80% AM from 2000...2700 MHz
EFT/B immunity IEC 61000-4-4	±4 kV at 5 kHz on signal ports
Surge transient immunity IEC 61000-4-5	±1k V line-line (DM) and ±2 kV line-earth (CM) on signal ports
Conducted RF immunity IEC 61000-4-6	10V rms with 1 kHz sine-wave 80% AM from 150 kHz...80 MHz

Certifications - 1756-0A8E

Certification ⁽¹⁾	1756-0A8E
UL	UL Listed Industrial Control Equipment, certified for US and Canada. See UL File E65584.
CSA	CSA Certified Process Control Equipment. See CSA File LR54689C. CSA Certified Process Control Equipment for Class I, Division 2 Group A,B,C,D Hazardous Locations. See CSA File LR69960C.
CE	European Union 2004/108/IEC EMC Directive, compliant with: <ul style="list-style-type: none"> • EN 61326-1; Meas./Control/Lab., Industrial Requirements • EN 61000-6-2; Industrial Immunity • EN 61000-6-4; Industrial Emissions • EN 61131-2; Programmable Controllers (Clause 8, Zone A & B) European Union 2006/95/EC LVD, compliant with: <ul style="list-style-type: none"> • EN 61131-2; Programmable Controllers
C-Tick	Australian Radiocommunications Act, compliant with: AS/NZS CISPR 11; Industrial Emissions
FM	FM Approved Equipment for use in Class I Division 2 Group A,B,C,D Hazardous Locations

(1) When marked. See the Product Certification link at <http://www.ab.com> for Declarations of Conformity, Certificates, and other certification details.

1756-0A16

ControlLogix AC (74...265V) output module

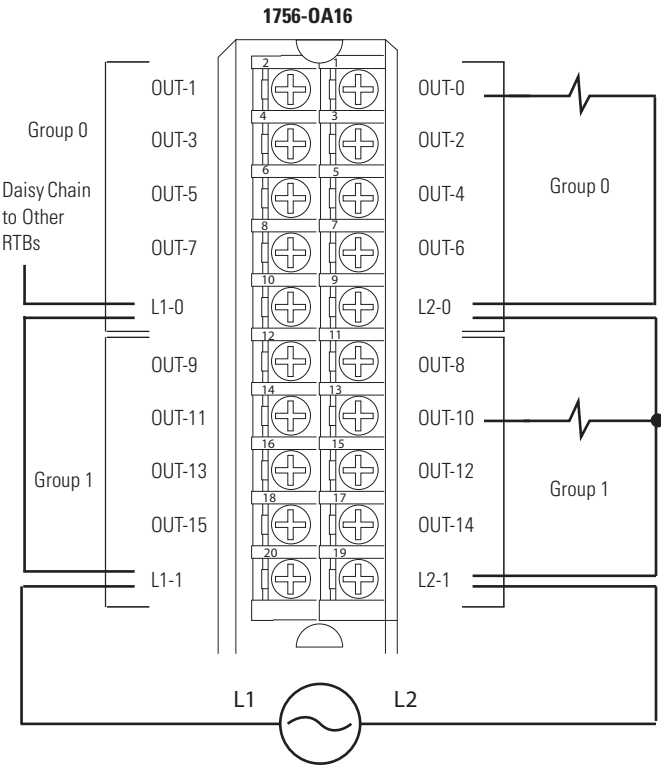
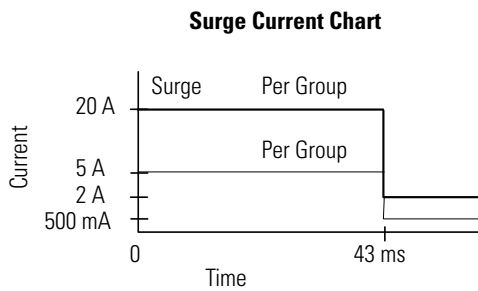
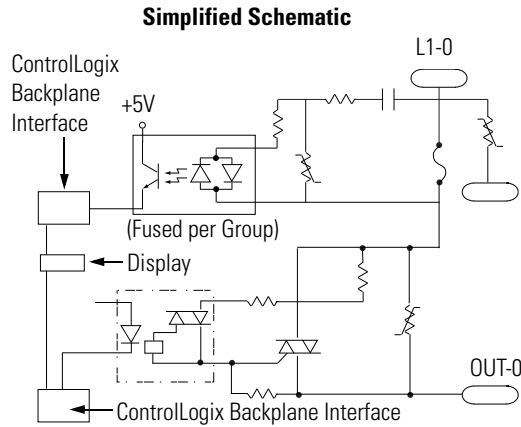

Diagnostic Specifications - 1756-0A16

Attribute	1756-0A16
Time stamp of diagnostics	±1 ms
Fuse blown	1 fuse and indicator/group

Technical Specifications - 1756-0A16

Attribute	1756-0A16
Outputs	16 mechanically fused/group (8 points/group)
Pilot duty	0.5 A
Voltage category	120/240V AC
Operating voltage range	74...265V AC 47...63 Hz
Output delay time OFF to ON	9.3 ms @ 60 Hz 11 ms @ 50 Hz
ON to OFF	9.3 ms @ 60 Hz 11 ms @ 50 Hz
Current draw @ 5.1V	400 mA

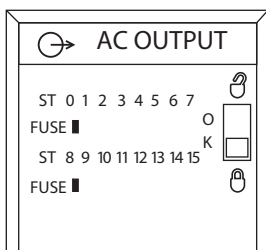

Technical Specifications - 1756-0A16

Attribute	1756-0A16
Current draw @ 24V	2 mA
Total backplane power	2.1 W
Power dissipation, max	6.5 W @ 60 °C (140 °F)
Thermal dissipation	22.17 BTU/hr
Off-state leakage current, max	3 mA per point
On-state voltage drop, max	1.5V @ 0.5 A 5.7V @ load current < 50 mA
Current per point, max	0.5 A @ 60 °C (140 °F)
Current per group, max	2 A @ 60 °C (140 °F)
Current per module, max	4 A @ 60 °C (140 °F)
Surge current per point	5 A for 43 ms per point, repeatable every 2 s @ 60 °C (140 °F)
Surge current per group	15 A for 43 ms per point, repeatable every 2 s @ 60 °C (140 °F)
Load current, min	10 mA per point
Commutating voltage	4V/μs for loads > 50 mA 0.2V/μs for loads < 50 mA ⁽¹⁾
Scheduled outputs	Synchronization within 16.7 s max, reference to the Coordinated System Time
Fault states per point	Hold last state, on or off (off is default)
States in Program mode per point	Hold last state, on or off (off is default)
Isolation voltage	250V (continuous), basic insulation type, outputs-to-backplane, and output group-to-group No isolation between individual group outputs Routine tested @ 1350V AC for 2 s
Inhibit voltage, max	Zero crossing 60V peak
Module keying	Electronic, software configurable
Fusing	Mechanically fused/group, 3.15 A @ 250V AC slow blow, 1500 A interruption current, Littelfuse p/n H2153.15
Removable terminal block	1756-TBNH 1756-TBSH
RTB keying	User-defined mechanical
Slot width	1
Wire category	1 ⁽²⁾
North American temperature code	T4
Enclosure type	None (open style)

(1) The commutating dv/dt of the output voltage (OUTPUT to L2) should not exceed 0.2V/ms for loads under 50 mA. The commutating dv/dt rating of the module for loads 50...500 mA (OUTPUT to L2) is 4V/ms maximum. If the commutating dv/dt rating of the TRIAC is exceeded, the TRIAC could latch on. If the commutating dv/dt rating is exceeded in the 10...50 mA range, a resistor may be added AC cross the output and L2. The purpose of this resistor is to increase the total output current to 50 mA ($I=V/R$). At 50 mA and above, the module has a higher commutating dv/dt rating. When adding a resistor for the output to L2, be sure it is rated for the power that it will dissipate ($P=(V**2)/R$). If the commutating dv/dt rating is exceeded in the 50...500 mA range, the L1 AC waveform could be at fault. Be sure the waveform is a good sinusoid, void of any anomalies such as distorted or flattened sections.

(2) Use this conductor category information for planning conductor routing as described in the system-level installation manual. See the Industrial Automation Wiring and Grounding Guidelines, publication [1770-4.1](#).

Environmental Specifications - 1756-0A16

Attribute	1756-0A16
Temperature, operating IEC 60068-2-1 (Test Ad, Operating Cold), IEC 60068-2-2 (Test Bd, Operating Dry Heat), IEC 60068-2-14 (Test Nb, Operating Thermal Shock)	0...60 °C (32...140 °F)
Temperature, surrounding air, max	60 °C (140 °F)
Temperature, storage IEC 60068-2-1 (Test Ab, Unpackaged Nonoperating Cold), IEC 60068-2-2 (Test Bb, Unpackaged Nonoperating Dry Heat), IEC 60068-2-14 (Test Na, Unpackaged Nonoperating Thermal Shock)	-40...85 °C (-40...185 °F)
Relative humidity IEC 60068-2-30 (Test Db, Unpackaged Nonoperating Damp Heat)	5...95% noncondensing
Vibration IEC 60068-2-6 (Test Fc, Operating)	2 g @ 10...500 Hz
Shock, operating IEC 60068-2-27 (Test Ea, Unpackaged Shock)	30 g
Shock, nonoperating IEC 60068-2-27 (Test Ea, Unpackaged Shock)	50 g
Emissions	CISPR 11: Group 1, Class A
ESD immunity IEC 61000-4-2	6 kV contact discharges 8 kV air discharges
Radiated RF immunity IEC 61000-4-3	10V/m with 1 kHz sine-wave 80% AM from 80... 2000 MHz 10V/m with 200 Hz 50% Pulse 100% AM @ 900 MHz 10V/m with 200 Hz 50% Pulse 100% AM @ 1890 MHz 3V/m with 1 kHz sine-wave 80% AM from 2000...2700 MHz
EFT/B immunity IEC 61000-4-4	±4 kV at 5 kHz on signal ports
Surge transient immunity IEC 61000-4-5	±1 kV line-line (DM) and ±2 kV line-earth (CM) on signal ports
Conducted RF immunity IEC 61000-4-6	10V rms with 1 kHz sine-wave 80% AM from 150 kHz...80 MHz
Oscillatory surge withstand IEEE C37.90.1	3 kV

Certifications - 1756-0A16

Certification ⁽¹⁾	1756-0A16
UL	UL Listed Industrial Control Equipment, certified for US and Canada. See UL File E65584.
CSA	CSA Certified Process Control Equipment. See CSA File LR54689C. CSA Certified Process Control Equipment for Class I, Division 2 Group A,B,C,D Hazardous Locations. See CSA File LR69960C.
CE	European Union 2004/108/IEC EMC Directive, compliant with: <ul style="list-style-type: none"> • EN 61326-1; Meas./Control/Lab., Industrial Requirements • EN 61000-6-2; Industrial Immunity • EN 61000-6-4; Industrial Emissions • EN 61131-2; Programmable Controllers (Clause 8, Zone A & B) European Union 2006/95/EC LVD, compliant with: <ul style="list-style-type: none"> • EN 61131-2; Programmable Controllers (Clause 11)
C-Tick	Australian Radiocommunications Act, compliant with: AS/NZS CISPR 11; Industrial Emissions
FM	FM Approved Equipment for use in Class I Division 2 Group A,B,C,D Hazardous Locations

(1) When marked. See the Product Certification link at <http://www.ab.com> for Declarations of Conformity, Certificates, and other certification details.

1756-0A16I

ControlLogix AC (74...265V) isolated output module

Simplified Schematic

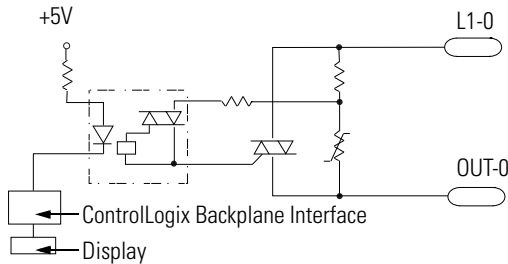

Surge Current Chart

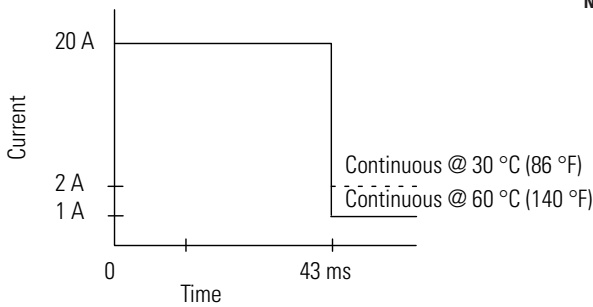

Isolated Wiring

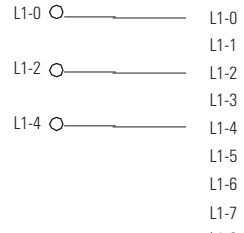

Nonisolated Wiring

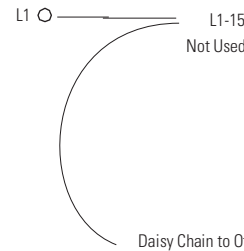

1756-0A16I

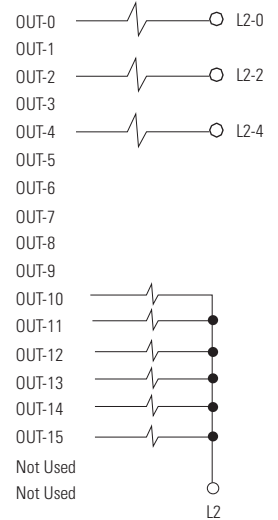
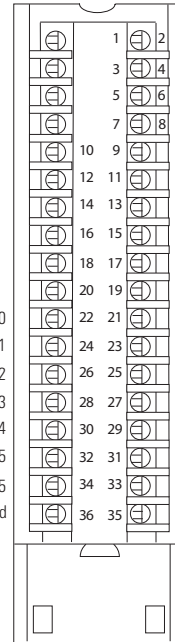

Additional jumper bars are available as cat. no. 1756-JMPR.

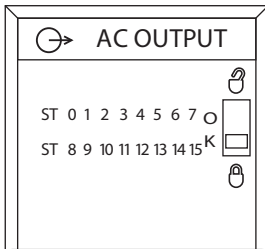

Technical Specifications - 1756-0A16I

Attribute	1756-0A16I
Outputs	16 individually isolated
Pilot duty	2 A
Voltage category	120/240V AC
Operating voltage range	74...265V AC 47...63 Hz
Output delay time	
OFF to ON	9.3 ms @ 60 Hz 11 ms @ 50 Hz
ON to OFF	9.3 ms @ 60 Hz 11 ms @ 50 Hz
Current draw @ 5.1V	300 mA
Current draw @ 24V	2.5 mA
Total backplane power	1.59 W
Power dissipation, max	5.5 W @ 60 °C (140 °F)
Thermal dissipation	18.76 BTU/hr
Off-state leakage current, max	3 mA per point

Technical Specifications - 1756-0A16I

Attribute	1756-0A16I
On-state voltage drop, max	1.5V peak @ 2 A 6V peak @ load current < 50 mA
Current per point, max	2 A @ 30 ° (86 °F) linear derating 1 A @ 60 °C (140 °F) linear derating
Current per module, max	5 A @ 30 °C (86 °F) linear derating 4 A @ 60 °C (140 °F) linear derating
Surge current per point	20 A for 43 ms per point, repeatable every 2 s @ 60 °C (140 °F)
Load current, min	10 mA per point
Commutating voltage	4V/μs for loads > 50 mA 0.2V/μs for loads < 50 mA ⁽¹⁾
Scheduled outputs	Synchronization within 16.7 s max, reference to the Coordinated System Time
Fault states per point	Hold last state, on or off (off is default)
States in Program mode per point	Hold last state, on or off (off is default)
Isolation voltage	250V (continuous), basic insulation type, outputs-to-backplane, and output-to-output Routine tested @ 1350V AC for 2 s
Inhibit voltage, max	Zero crossing 60V peak
Module keying	Electronic, software configurable
Fusing	Not protected. A fused IFM is recommended to protect outputs
Removable terminal block	1756-TBCH 1756-TBS6H
RTB keying	User-defined mechanical
Slot width	1
Wire category	1 ⁽²⁾
North American temperature code	T4A
Enclosure type	None (open style)

(1) The commutating dv/dt of the output voltage (OUTPUT to L2) should not exceed 0.2V/ms for loads under 50 mA. The commutating dv/dt rating of the module for loads 50...500 mA (OUTPUT to L2) is 4V/ms maximum. If the commutating dv/dt rating of the TRIAC is exceeded, the TRIAC could latch on. If the commutating dv/dt rating is exceeded in the 10...50 mA range, a resistor may be added AC cross the output and L2. The purpose of this resistor is to increase the total output current to 50 mA ($I=V/R$). At 50 mA and above, the module has a higher commutating dv/dt rating. When adding a resistor for the output to L2, be sure it is rated for the power that it will dissipate ($P=(V**2)/R$). If the commutating dv/dt rating is exceeded in the 50...500 mA range, the L1 AC waveform could be at fault. Be sure the waveform is a good sinusoid, void of any anomalies such as distorted or flattened sections.

(2) Use this conductor category information for planning conductor routing as described in the system-level installation manual. See the Industrial Automation Wiring and Grounding Guidelines, publication [1770-4.1](#).

Environmental Specifications - 1756-0A16I

Attribute	1756-0A16I
Temperature, operating IEC 60068-2-1 (Test Ad, Operating Cold), IEC 60068-2-2 (Test Bd, Operating Dry Heat), IEC 60068-2-14 (Test Nb, Operating Thermal Shock)	0...60 °C (32...140 °F)
Temperature, surrounding air, max	60 °C (140 °F)
Temperature, storage IEC 60068-2-1 (Test Ab, Unpackaged Nonoperating Cold), IEC 60068-2-2 (Test Bb, Unpackaged Nonoperating Dry Heat), IEC 60068-2-14 (Test Na, Unpackaged Nonoperating Thermal Shock)	-40...85 °C (-40...185 °F)
Relative humidity IEC 60068-2-30 (Test Db, Unpackaged Nonoperating Damp Heat)	5...95% noncondensing
Vibration IEC 60068-2-6 (Test Fc, Operating)	2 g @ 10...500 Hz
Shock, operating IEC 60068-2-27 (Test Ea, Unpackaged Shock)	30 g
Shock, nonoperating IEC 60068-2-27 (Test Ea, Unpackaged Shock)	50 g
Emissions	CISPR 11: Group 1, Class A
ESD immunity IEC 61000-4-2	6 kV contact discharges 8 kV air discharges
Radiated RF immunity IEC 61000-4-3	10V/m with 1 kHz sine-wave 80% AM from 80...2000 MHz 10V/m with 200 Hz 50% Pulse 100% AM @ 900 MHz 10V/m with 200 Hz 50% Pulse 100% AM @ 1890 MHz 3V/m with 1 kHz sine-wave 80% AM from 2000...2700 MHz
EFT/B immunity IEC 61000-4-4	±4 kV at 5 kHz on signal ports
Surge transient immunity IEC 61000-4-5	±1 kV line-line (DM) and ±2 kV line-earth (CM) on signal ports
Conducted RF immunity IEC 61000-4-6	10V rms with 1 kHz sine-wave 80% AM from 150 kHz...80 MHz
Oscillatory surge withstand IEEE C37.90.1	3 kV

Certifications - 1756-0A16I

Certification ⁽¹⁾	1756-0A16I
UL	UL Listed Industrial Control Equipment, certified for US and Canada. See UL File E65584.
CSA	CSA Certified Process Control Equipment. See CSA File LR54689C. CSA Certified Process Control Equipment for Class I, Division 2 Group A,B,C,D Hazardous Locations. See CSA File LR69960C.
CE	European Union 2004/108/IEC EMC Directive, compliant with: <ul style="list-style-type: none"> • EN 61326-1; Meas./Control/Lab., Industrial Requirements • EN 61000-6-2; Industrial Immunity • EN 61000-6-4; Industrial Emissions • EN 61131-2; Programmable Controllers (Clause 8, Zone A & B) European Union 2006/95/EC LVD, compliant with: <ul style="list-style-type: none"> • EN 61131-2; Programmable Controllers
C-Tick	Australian Radiocommunications Act, compliant with: AS/NZS CISPR 11; Industrial Emissions
FM	FM Approved Equipment for use in Class I Division 2 Group A,B,C,D Hazardous Locations
TÜV	TÜV Certified for Functional Safety ⁽²⁾ : Capable of SIL 2

(1) When marked. See the Product Certification link at <http://www.ab.com> for Declarations of Conformity, Certificates, and other certification details.(2) When used with specified firmware revisions and in accordance with application guidelines described in Using ControlLogix in SIL2 Applications Safety Reference Manual, publication [1756-RM001](#).

1756-OB8

ControlLogix DC (10...30V) output module

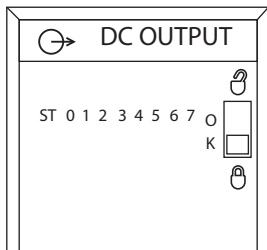
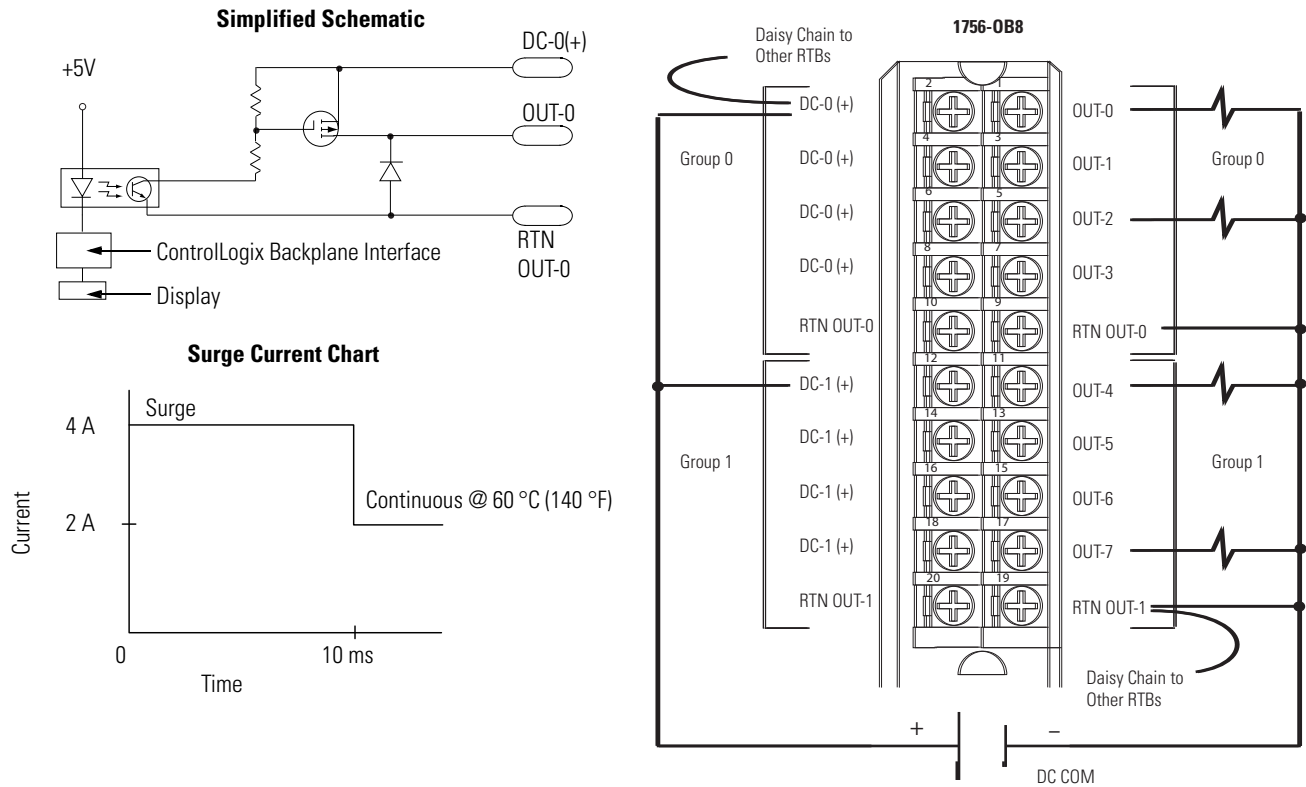

Technical Specifications - 1756-OB8

Attribute	1756-OB8
Outputs	8 (4 points/common)
Pilot duty	2 A
Voltage category	12/24V DC source
Operating voltage range	10...30V DC
Output delay time OFF to ON ON to OFF	1 ms max 2 ms max
Current draw @ 5.1V	165 mA
Current draw @ 24V	2 mA
Total backplane power	0.89 W
Power dissipation, max	2.5 W @ 60 °C (140 °F)
Thermal dissipation	8.53 BTU/hr
Off-state leakage current, max	1 mA per point
On-state voltage drop, max	1.2V DC @ 2A
Current per point, max	2 A @ 60 °C (140 °F)
Current per module, max	8 A @ 60 °C (140 °F)

Technical Specifications - 1756-OB8

Attribute	1756-OB8
Surge current per point	4 A for 10 ms each, repeatable every 1 s @ 60 °C (140 °F)
Load current, min	2 mA per point
Scheduled outputs	Synchronization within 16.7 s max, reference to the Coordinated System Time
Fault states per point	Hold last state, on or off (off is default)
States in Program mode per point	Hold last state, on or off (off is default)
Isolation voltage	250V (continuous), basic insulation type, outputs-to-backplane, and output group-to-group No isolation between individual group outputs Routine tested @ 1350V AC for 2 s
Module keying	Electronic, software configurable
Fusing	Not protected. A fused IFM is recommended to protect outputs
Removable terminal block	1756-TBNH 1756-TBSH
RTB keying	User-defined mechanical
Slot width	1
Wire category	1 ⁽¹⁾
North American temperature code	T4A
IEC temperature code	T4
Enclosure type	None (open-style)

(1) Use this conductor category information for planning conductor routing as described in the system-level installation manual. See the Industrial Automation Wiring and Grounding Guidelines, publication [1770-4.1](#).

Environmental Specifications - 1756-OB8

Attribute	1756-OB8
Temperature, operating IEC 60068-2-1 (Test Ad, Operating Cold), IEC 60068-2-2 (Test Bd, Operating Dry Heat), IEC 60068-2-14 (Test Nb, Operating Thermal Shock)	0...60 °C (32...140 °F)
Temperature, surrounding air, max	60 °C (140 °F)
Temperature, storage IEC 60068-2-1 (Test Ab, Unpackaged Nonoperating Cold), IEC 60068-2-2 (Test Bb, Unpackaged Nonoperating Dry Heat), IEC 60068-2-14 (Test Na, Unpackaged Nonoperating Thermal Shock)	-40...85 °C (-40...185 °F)
Relative humidity IEC 60068-2-30 (Test Db, Unpackaged Nonoperating Damp Heat)	5...95% noncondensing
Vibration IEC 60068-2-6 (Test Fc, Operating)	2 g @ 10...500 Hz
Shock, operating IEC 60068-2-27 (Test Ea, Unpackaged Shock)	30 g
Shock, nonoperating IEC 60068-2-27 (Test Ea, Unpackaged Shock)	50 g
Emissions	CISPR 11: Group 1, Class A
ESD immunity IEC 61000-4-2	6 kV contact discharges 8 kV air discharges

Environmental Specifications - 1756-OB8

Attribute	1756-OB8
Radiated RF immunity IEC 61000-4-3	10V/m with 1 kHz sine-wave 80% AM from 80... 2000 MHz 10V/m with 200 Hz 50% Pulse 100% AM @ 900 MHz 10V/m with 200 Hz 50% Pulse 100% AM @ 1890 MHz 3V/m with 1 kHz sine-wave 80% AM from 2000...2700 MHz
EFT/B immunity IEC 61000-4-4	±4 kV at 5 kHz on signal ports
Surge transient immunity IEC 61000-4-5	±1 kV line-line (DM) and ±2 kV line-earth (CM) on signal ports
Conducted RF immunity IEC 61000-4-6	10V rms with 1 kHz sine-wave 80% AM from 150 kHz...80 MHz

Certifications - 1756-OB8

Certification ⁽¹⁾	1756-OB8
UL	UL Listed Industrial Control Equipment, certified for US and Canada. See UL File E65584.
CSA	CSA Certified Process Control Equipment. See CSA File LR54689C. CSA Certified Process Control Equipment for Class I, Division 2 Group A,B,C,D Hazardous Locations. See CSA File LR69960C.
CE	European Union 2004/108/IEC EMC Directive, compliant with: <ul style="list-style-type: none"> • EN 61326-1; Meas./Control/Lab., Industrial Requirements • EN 61000-6-2; Industrial Immunity • EN 61000-6-4; Industrial Emissions • EN 61131-2; Programmable Controllers (Clause 8, Zone A & B) European Union 2006/95/EC LVD, compliant with: <ul style="list-style-type: none"> • EN 61131-2; Programmable Controllers (Clause 11)
C-Tick	Australian Radiocommunications Act, compliant with: AS/NZS CISPR 11; Industrial Emissions
Ex	European Union 94/9/EC ATEX Directive, compliant with: <ul style="list-style-type: none"> • EN 60079-15; Potentially Explosive Atmospheres, Protection "n" • EN 60079-0; General Requirements II 3 G Ex nA IIC T4 X
FM	FM Approved Equipment for use in Class I Division 2 Group A,B,C,D Hazardous Locations

(1) When marked. See the Product Certification link at <http://www.ab.com> for Declarations of Conformity, Certificates, and other certification details.

1756-OB8EI

ControlLogix DC (10...30V) electronically-fused, isolated output module

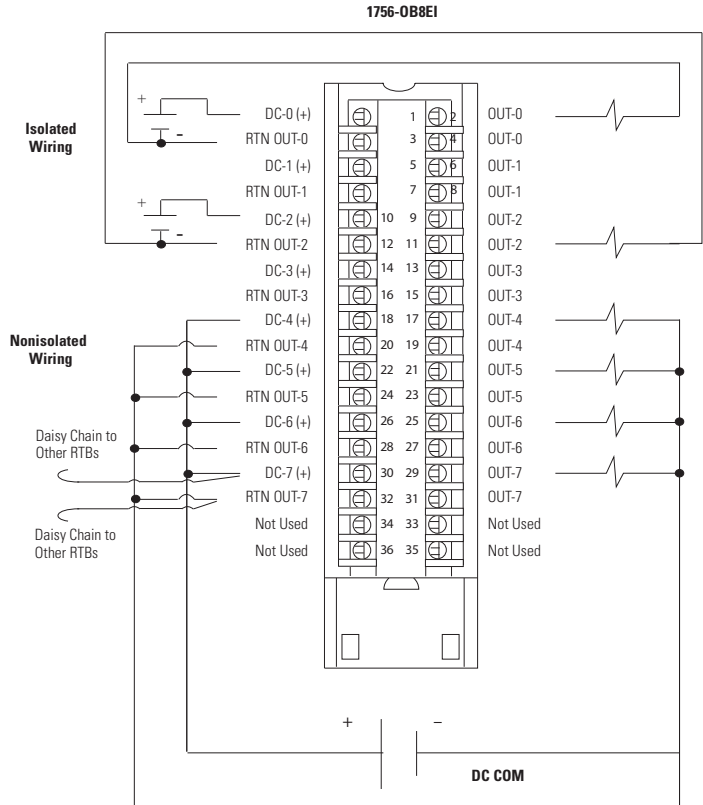
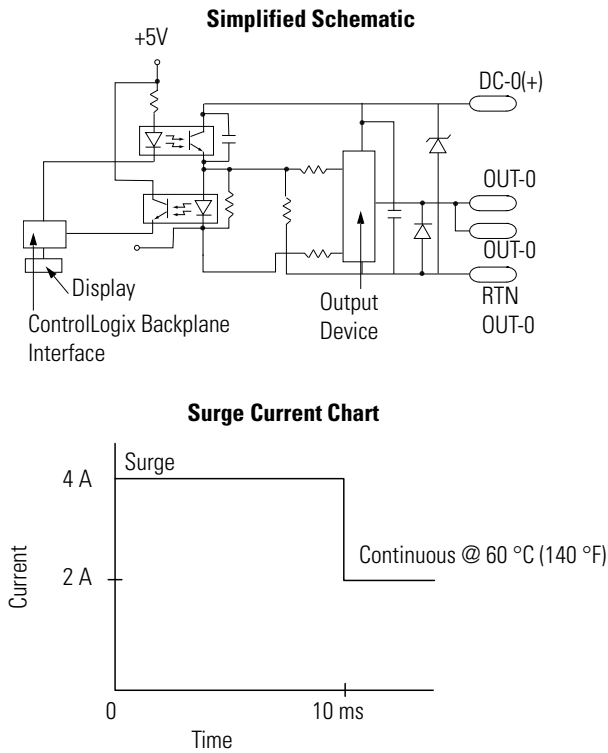

Diagnostic Specifications - 1756-OB8EI

Attribute	1756-OB8EI
Short trip	> 4.5 A for 500 μ s max (output on, then short) > 4.5 A for 1.5 ms max (output on into short)
Timestamp of diagnostics	\pm 1 ms

Technical Specifications - 1756-OB8EI

Attribute	1756-OB8EI
Outputs	8 individually isolated
Pilot duty	2 A
Voltage category	12/24V DC source
Operating voltage range	10...30V DC
Output delay time	OFF to ON ON to OFF
	1 ms max 5 ms max
Current draw @ 5.1V	250 mA
Current draw @ 24V	2 mA
Total backplane power	1.30 W

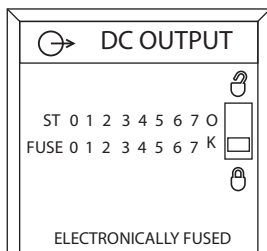

Technical Specifications - 1756-OB8EI

Attribute	1756-OB8EI
Power dissipation, max	4.7 W @ 60 °C (140 °F)
Thermal dissipation	16.03 BTU/hr
Off-state leakage current, max	1 mA per point
On-state voltage drop, max	1.2V DC @ 2 A
Current per point, max	2 A @ 60 °C (140 °F)
Current per module, max	10 A @ 60 °C (140 °F) 16 A @ 55 °C (131°F) linear derating
Surge current per point	4 A for 10 ms each, repeatable every 2 s
Load current, min	3 mA
Scheduled outputs	Synchronization within 16.7 s max, reference to the Coordinated System Time
Fault states per point	Hold last state, on or off (off is default)
States in Program mode per point	Hold last state, on or off (off is default)
Isolation voltage	250V (continuous), basic insulation type, outputs-to-backplane, and output-to-output Routine tested @ 1350V AC for 2 s
Module keying	Electronic, software configurable
Fusing	Electronically fused per point
Removable terminal block	1756-TBCH 1756-TBS6H
RTB keying	User-defined mechanical
Slot width	1
Wire category	1 ⁽¹⁾
North American temperature code	T4A
IEC temperature code	T4
Enclosure type	None (open-style)

(1) Use this conductor category information for planning conductor routing as described in the system-level installation manual. See the Industrial Automation Wiring and Grounding Guidelines, publication [1770-4.1](#).

Environmental Specifications - 1756-OB8EI

Attribute	1756-OB8EI
Temperature, operating IEC 60068-2-1 (Test Ad, Operating Cold), IEC 60068-2-2 (Test Bd, Operating Dry Heat), IEC 60068-2-14 (Test Nb, Operating Thermal Shock)	0...60 °C (32...140 °F)
Temperature, surrounding air, max	60 °C (140 °F)
Temperature, storage IEC 60068-2-1 (Test Ab, Unpackaged Nonoperating Cold), IEC 60068-2-2 (Test Bb, Unpackaged Nonoperating Dry Heat), IEC 60068-2-14 (Test Na, Unpackaged Nonoperating Thermal Shock)	-40...85 °C (-40...185 °F)
Relative humidity IEC 60068-2-30 (Test Db, Unpackaged Nonoperating Damp Heat)	5...95% noncondensing
Vibration IEC 60068-2-6 (Test Fc, Operating)	2 g @ 10...500 Hz
Shock, operating IEC 60068-2-27 (Test Ea, Unpackaged Shock)	30 g

Environmental Specifications - 1756-OB8EI

Attribute	1756-OB8EI
Shock, nonoperating IEC 60068-2-27 (Test Ea, Unpackaged Shock)	50 g
Emissions	CISPR 11: Group 1, Class A
ESD immunity IEC 61000-4-2	6 kV contact discharges 8 kV air discharges
Radiated RF immunity IEC 61000-4-3	10V/m with 1 kHz sine-wave 80% AM from 80... 2000 MHz 10V/m with 200 Hz 50% Pulse 100% AM @ 900 MHz 10V/m with 200 Hz 50% Pulse 100% AM @ 1890 MHz 3V/m with 1 kHz sine-wave 80% AM from 2000...2700 MHz
EFT/B immunity IEC 61000-4-4	±4 kV at 5 kHz on signal ports
Surge transient immunity IEC 61000-4-5	±1 kV line-line (DM) and ±2 kV line-earth (CM) on signal ports
Conducted RF immunity IEC 61000-4-6	10V rms with 1 kHz sine-wave 80% AM from 150 kHz...80 MHz

Certifications - 1756-OB8EI

Certification ⁽¹⁾	1756-OB8EI
UL	UL Listed Industrial Control Equipment, certified for US and Canada. See UL File E65584.
CSA	CSA Certified Process Control Equipment. See CSA File LR54689C. CSA Certified Process Control Equipment for Class I, Division 2 Group A,B,C,D Hazardous Locations. See CSA File LR69960C.
CE	European Union 2004/108/IEC EMC Directive, compliant with: <ul style="list-style-type: none"> • EN 61326-1; Meas./Control/Lab., Industrial Requirements • EN 61000-6-2; Industrial Immunity • EN 61000-6-4; Industrial Emissions • EN 61131-2; Programmable Controllers (Clause 8, Zone A & B) European Union 2006/95/EC LVD, compliant with: <ul style="list-style-type: none"> • EN 61131-2; Programmable Controllers (Clause 11)
C-Tick	Australian Radiocommunications Act, compliant with: AS/NZS CISPR 11; Industrial Emissions
Ex	European Union 94/9/EC ATEX Directive, compliant with: <ul style="list-style-type: none"> • EN 60079-15; Potentially Explosive Atmospheres, Protection "n" • EN 60079-0; General Requirements II 3 G Ex nA IIC T4 X
FM	FM Approved Equipment for use in Class I Division 2 Group A,B,C,D Hazardous Locations
TÜV	TÜV Certified for Functional Safety ⁽²⁾ : Capable of SIL 2

(1) When marked. See the Product Certification link at <http://www.ab.com> for Declarations of Conformity, Certificates, and other certification details.

(2) When used with specified firmware revisions and in accordance with application guidelines described in Using ControlLogix in SIL2 Applications Safety Reference Manual, publication [1756-RM001](#).

1756-OB8I

ControlLogix DC (10...30V) isolated output module

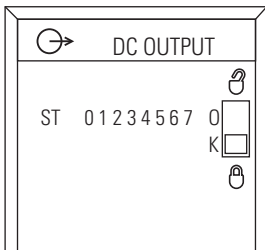
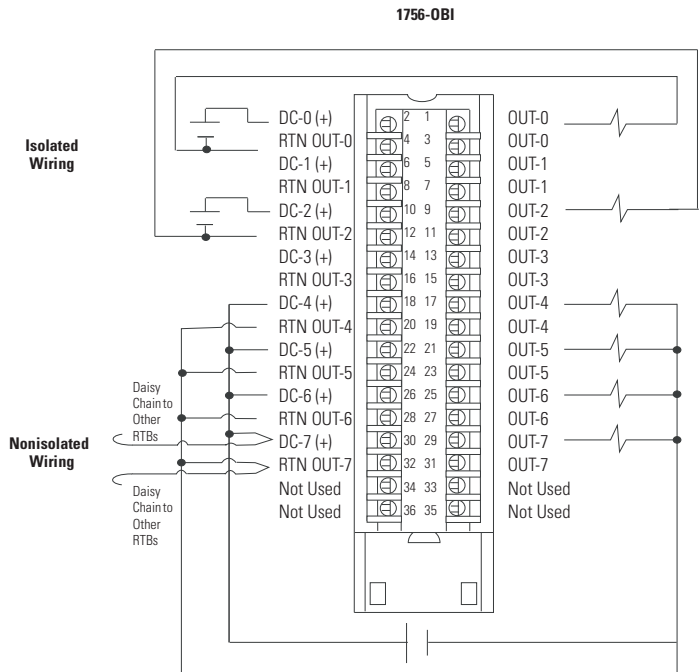
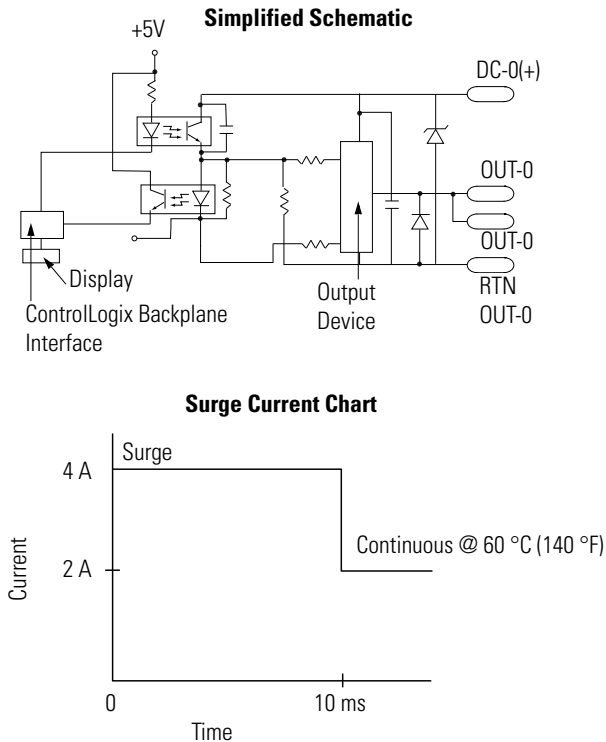

Technical Specifications - 1756-OB8I

Attribute	1756-OB8I
Outputs	8 individually isolated
Pilot duty	2 A
Voltage category	12/24V DC source
Operating voltage range	10...30V DC
Output delay time OFF to ON ON to OFF	1 ms max 2 ms max
Current draw @ 5.1V	165 mA
Current draw @ 24V	2 mA
Total backplane power	0.89 W
Power dissipation, max	4.6W @ 60 °C (140 °F)
Thermal dissipation	15.70 BTU/hr
Off-state leakage current, max	0.5 mA per point
On-state voltage drop, max	0.5V DC @ 2 A
Current per point, max	2 A @ 60 °C (140 °F)
Current per module, max	16 A @ 60 °C (140 °F)
Surge current per point	4 A for 10 ms each, repeatable every 1 s @ 60 °C (140 °F)
Load current, min	2 mA

Technical Specifications - 1756-OB8I

Attribute	1756-OB8I
Scheduled outputs	Synchronization within 16.7 s max, reference to the Coordinated System Time
Fault states per point	Hold last state, on or off (off is default)
States in Program mode per point	Hold last state, on or off (off is default)
Isolation voltage	250V (continuous), reinforced insulation type, outputs-to-backplane 250V (continuous), basic insulation type, output-to-output Routine tested @ 1350V AC for 2 s
Module keying	Electronic, software configurable
Fusing	Not protected. A fused IFM is recommended to protect outputs
Removable terminal block	1756-TBCH 1756-TBS6H
RTB keying	User-defined mechanical
Slot width	1
Wire category	1 ⁽¹⁾
North American temperature code	T4A
Enclosure type	None (open-style)

(1) Use this conductor category information for planning conductor routing as described in the system-level installation manual. See the Industrial Automation Wiring and Grounding Guidelines, publication [1770-4.1](#).

Environmental Specifications - 1756-OB8I

Attribute	1756-OB8I
Temperature, operating IEC 60068-2-1 (Test Ad, Operating Cold), IEC 60068-2-2 (Test Bd, Operating Dry Heat), IEC 60068-2-14 (Test Nb, Operating Thermal Shock)	0...60 °C (32...140 °F)
Temperature, surrounding air, max	60 °C (140 °F)
Temperature, storage IEC 60068-2-1 (Test Ab, Unpackaged Nonoperating Cold), IEC 60068-2-2 (Test Bb, Unpackaged Nonoperating Dry Heat), IEC 60068-2-14 (Test Na, Unpackaged Nonoperating Thermal Shock)	-40...85 °C (-40...185 °F)
Relative humidity IEC 60068-2-30 (Test Db, Unpackaged Nonoperating Damp Heat)	5...95% noncondensing
Vibration IEC 60068-2-6 (Test Fc, Operating)	2 g @ 10...500 Hz
Shock, operating IEC 60068-2-27 (Test Ea, Unpackaged Shock)	30 g
Shock, nonoperating IEC 60068-2-27 (Test Ea, Unpackaged Shock)	50 g
Emissions	CISPR 11: Group 1, Class A
ESD immunity IEC 61000-4-2	6 kV contact discharges 8k V air discharges
Radiated RF immunity IEC 61000-4-3	10V/m with 1 kHz sine-wave 80% AM from 80...2000 MHz 10V/m with 200 Hz 50% Pulse 100% AM @ 900 MHz 10V/m with 200 Hz 50% Pulse 100% AM @ 1890 MHz 3V/m with 1k Hz sine-wave 80% AM from 2000...2700 MHz

Environmental Specifications - 1756-OB8I

Attribute	1756-OB8I
EFT/B immunity IEC 61000-4-4	±4 kV at 5 kHz on signal ports
Surge transient immunity IEC 61000-4-5	±1 kV line-line (DM) and ±2 kV line-earth (CM) on signal ports
Conducted RF immunity IEC 61000-4-6	10V rms with 1 kHz sine-wave 80% AM from 150 kHz...80 MHz

Certifications - 1756-OB8I

Certification ⁽¹⁾	1756-OB8I
UL	UL Listed Industrial Control Equipment, certified for US and Canada. See UL File E65584.
CSA	CSA Certified Process Control Equipment. See CSA File LR54689C. CSA Certified Process Control Equipment for Class I, Division 2 Group A,B,C,D Hazardous Locations. See CSA File LR69960C.
CE	European Union 2004/108/IEC EMC Directive, compliant with: <ul style="list-style-type: none"> • EN 61326-1; Meas./Control/Lab., Industrial Requirements • EN 61000-6-2; Industrial Immunity • EN 61000-6-4; Industrial Emissions • EN 61131-2; Programmable Controllers (Clause 8, Zone A & B) European Union 2006/95/EC LVD, compliant with: <ul style="list-style-type: none"> • EN 61131-2; Programmable Controllers (Clause 11)
C-Tick	Australian Radiocommunications Act, compliant with: AS/NZS CISPR 11; Industrial Emissions

(1) When marked. See the Product Certification link at <http://www.ab.com> for Declarations of Conformity, Certificates, and other certification details.

1756-OB16D

ControlLogix DC (19.2...30V) diagnostic output module

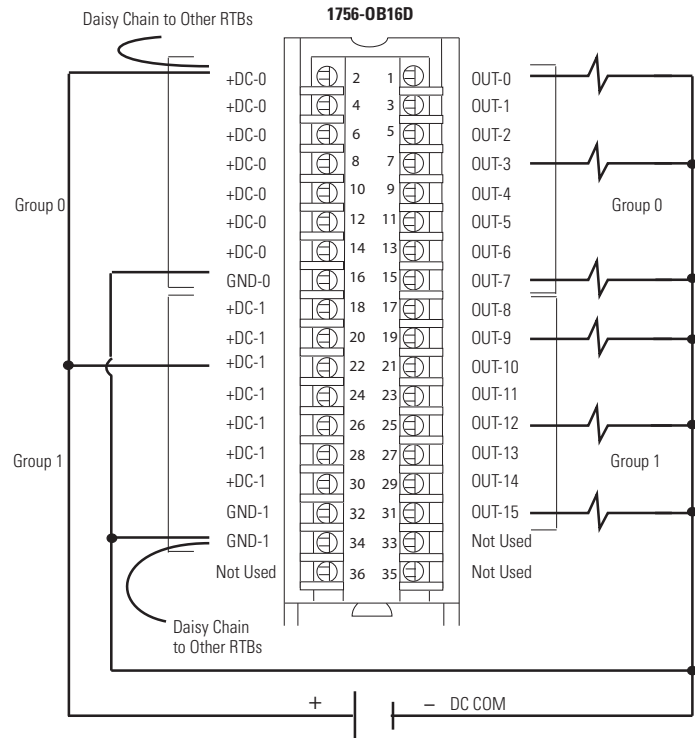
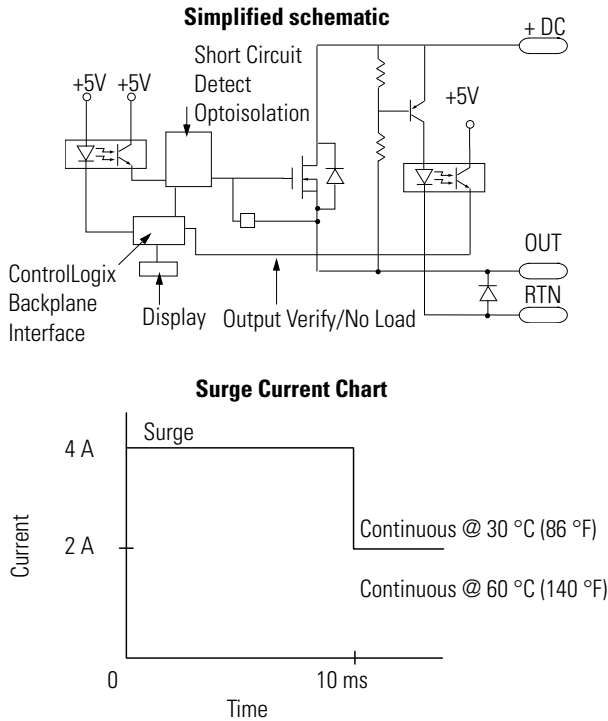

Diagnostic Specifications - 1756-OB16D

Attribute	1756-OB16D
Short trip	8 A for 180 ms 10 A for 120 ms
No load	Off-state detection only
Output verification	On-state detection only
Pulse test	Configurable maximum pulse width
Time stamp of diagnostics	±1 ms

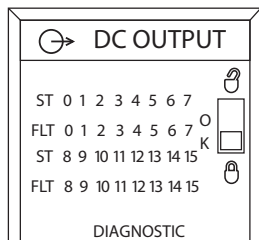

Technical Specifications - 1756-OB16D

Attribute	1756-OB16D
Outputs	16 diagnostic (8 points/group)
Pilot duty	2 A @ 30 °C (86 °F) DC-13SQ 1 A @ 60 °C (140 °F) linear derating 8 A combined continuous max @ 30 °C (86 °F) 4 A @ 60 °C (140 °F)
Voltage category	24V DC source
Operating voltage range	19.2...30V DC
Output delay time	60 μs nom/1 ms max 630 μs nom/5 ms max

Technical Specifications - 1756-OB16D

Attribute	1756-OB16D
Current draw @ 5.1V	250 mA
Current draw @ 24V	140 mA
Total backplane power	4.64 W
Power dissipation, max	3.3 W @ 60 °C (140 °F)
Thermal dissipation	11.25 BTU/hr
Off-state leakage current per point, max	1 mA per point
On-state voltage drop, max	1.2V DC @ 2A
Current per point, max	2 A @ 30 °C (86 °F) linear derating 1 A @ 60 °C (140 °F) linear derating
Current per module, max	8 A @ 30 °C (86 °F) linear derating 4 A @ 60 °C (140 °F) linear derating
Surge current per point	4 A for 10 ms per point, repeatable every 1 s
Load current, min	3 mA per point
Scheduled outputs	Synchronization within 16.7 s max, reference to the Coordinated System Time
Fault states per point	Hold last state, on or off (off is default)
States in Program mode per point	Hold last state, on or off (off is default)
Isolation voltage	250V (continuous), basic insulation type, outputs-to-backplane, and output group-to-group No isolation between individual group outputs Routine tested @ 1350V AC for 2 s
Module keying	Electronic, software configurable
Fusing	Electronically fused per point
Removable terminal block	1756-TBCH 1756-TBS6H
RTB keying	User-defined mechanical
Slot width	1
Wire category	1 ⁽¹⁾
North American temperature code	T4A
IEC temperature code	T4
Enclosure type	None (open-style)

(1) Use this conductor category information for planning conductor routing as described in the system-level installation manual. See the Industrial Automation Wiring and Grounding Guidelines, publication [1770-4.1](#).

Environmental Specifications - 1756-OB16D

Attribute	1756-OB16D
Temperature, operating IEC 60068-2-1 (Test Ad, Operating Cold), IEC 60068-2-2 (Test Bd, Operating Dry Heat), IEC 60068-2-14 (Test Nb, Operating Thermal Shock)	0...60 °C (32...140 °F)
Temperature, surrounding air, max	60 °C (140 °F)
Temperature, storage IEC 60068-2-1 (Test Ab, Unpackaged Nonoperating Cold), IEC 60068-2-2 (Test Bb, Unpackaged Nonoperating Dry Heat), IEC 60068-2-14 (Test Na, Unpackaged Nonoperating Thermal Shock)	-40...85 °C (-40...185 °F)
Relative humidity IEC 60068-2-30 (Test Db, Unpackaged Nonoperating Damp Heat)	5...95% noncondensing

Environmental Specifications - 1756-OB16D

Attribute	1756-OB16D
Vibration IEC 60068-2-6 (Test Fc, Operating)	2 g @ 10...500 Hz
Shock, operating IEC 60068-2-27 (Test Ea, Unpackaged Shock)	30 g
Shock, nonoperating IEC 60068-2-27 (Test Ea, Unpackaged Shock)	50 g
Emissions	CISPR 11: Group 1, Class A
ESD immunity IEC 61000-4-2	6 kV contact discharges 8 kV air discharges
Radiated RF immunity IEC 61000-4-3	10V/m with 1 kHz sine-wave 80% AM from 80... 2000 MHz 10V/m with 200 Hz 50% Pulse 100% AM @ 900 MHz 10V/m with 200 Hz 50% Pulse 100% AM @ 1890 MHz 3V/m with 1k Hz sine-wave 80% AM from 2000...2700 MHz
EFT/B immunity IEC 61000-4-4	±4 kV at 5 kHz on signal ports
Surge transient immunity IEC 61000-4-5	±1 kV line-line (DM) and ±2 kV line-earth (CM) on signal ports
Conducted RF immunity IEC 61000-4-6	10V rms with 1 kHz sine-wave 80% AM from 150 kHz...80 MHz

Certifications - 1756-OB16D

Certification ⁽¹⁾	1756-OB16D
UL	UL Listed Industrial Control Equipment, certified for US and Canada. See UL File E65584.
CSA	CSA Certified Process Control Equipment. See CSA File LR54689C. CSA Certified Process Control Equipment for Class I, Division 2 Group A,B,C,D Hazardous Locations. See CSA File LR69960C.
CE	European Union 2004/108/IEC EMC Directive, compliant with: <ul style="list-style-type: none"> • EN 61326-1; Meas./Control/Lab., Industrial Requirements • EN 61000-6-2; Industrial Immunity • EN 61000-6-4; Industrial Emissions • EN 61131-2; Programmable Controllers (Clause 8, Zone A & B) European Union 2006/95/EC LVD, compliant with: <ul style="list-style-type: none"> • EN 61131-2; Programmable Controllers (Clause 11)
C-Tick	Australian Radiocommunications Act, compliant with: AS/NZS CISPR 11; Industrial Emissions
Ex	European Union 94/9/EC ATEX Directive, compliant with: <ul style="list-style-type: none"> • EN 60079-15; Potentially Explosive Atmospheres, Protection "n" • EN 60079-0; General Requirements II 3 G Ex nA IIC T4 X
FM	FM Approved Equipment for use in Class I Division 2 Group A,B,C,D Hazardous Locations
TÜV	TÜV Certified for Functional Safety ⁽²⁾ . Capable of SIL 2

(1) When marked. See the Product Certification link at <http://www.ab.com> for Declarations of Conformity, Certificates, and other certification details.

(2) When used with specified firmware revisions.

1756-OB16E

ControlLogix DC (10...31.2V) electronically-fused output module

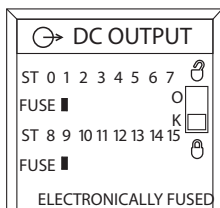
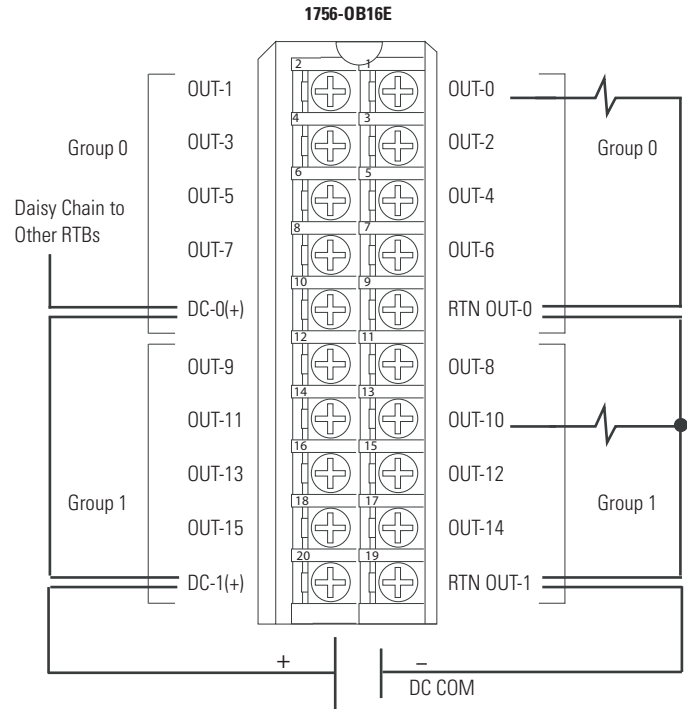
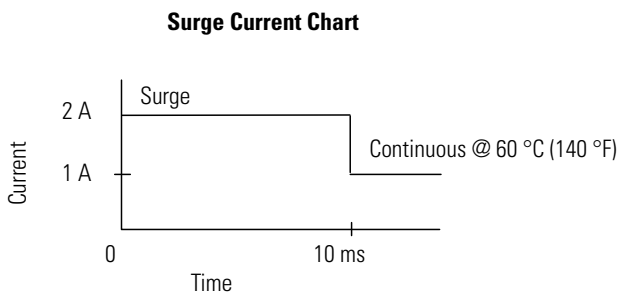
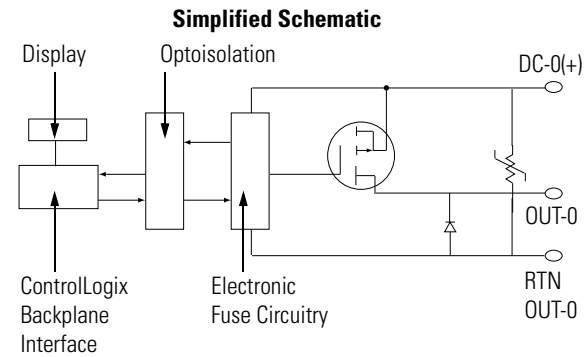

Technical Specifications - 1756-OB16E

Attribute	1756-OB16E
Outputs	16 electronically fused (8 points/group)
Voltage category	12/24V DC source
Operating voltage range	10...31.2V DC
Output delay time OFF to ON ON to OFF	70 μs nom/1 ms max 360 μs nom/1 ms max
Current draw @ 5.1V	250 mA
Current draw @ 24V	2 mA
Total backplane power	1.32 W
Power dissipation, max	4.1 W @ 60 °C (140 °F)
Thermal dissipation	13.98 BTU/hr
Off-state leakage current per point, max	1 mA per point
On-state voltage drop, max	400 mV DC @ 1 A
Current per point, max	1 A @ 60 °C (140 °F)
Current per module, max	8 A @ 60 °C (140 °F)
Surge current per point	2 A for 10 ms per point, repeatable every 2 s @ 60 °C (140 °F)
Load current, min	3 mA per point

Technical Specifications - 1756-OB16E

Attribute	1756-OB16E
Scheduled outputs	Synchronization within 16.7 s max, reference to the Coordinated System Time
Fault states per point	Hold last state, on or off (off is default)
States in Program mode per point	Hold last state, on or off (off is default)
Isolation voltage	250V (continuous), basic insulation type, outputs-to-backplane, and output group-to-group No isolation between individual group outputs Routine tested @ 1350V AC for 2 s
Module keying	Electronic, software configurable
Fusing	Electronically fused per group
Removable terminal block	1756-TBNH 1756-TBSH
RTB keying	User-defined mechanical
Slot width	1
Wire category	1 ⁽¹⁾
North American temperature code	T4
IEC temperature code	T4
Enclosure type	None (open-style)

(1) Use this conductor category information for planning conductor routing as described in the system-level installation manual. See the Industrial Automation Wiring and Grounding Guidelines, publication [1770-4.1](#).

Environmental Specifications - 1756-OB16E

Attribute	1756-OB16E
Temperature, operating IEC 60068-2-1 (Test Ad, Operating Cold), IEC 60068-2-2 (Test Bd, Operating Dry Heat), IEC 60068-2-14 (Test Nb, Operating Thermal Shock)	0...60 °C (32...140 °F)
Temperature, surrounding air, max	60 °C (140 °F)
Temperature, storage IEC 60068-2-1 (Test Ab, Unpackaged Nonoperating Cold), IEC 60068-2-2 (Test Bb, Unpackaged Nonoperating Dry Heat), IEC 60068-2-14 (Test Na, Unpackaged Nonoperating Thermal Shock)	-40...85 °C (-40...185 °F)
Relative humidity IEC 60068-2-30 (Test Db, Unpackaged Nonoperating Damp Heat)	5...95% noncondensing
Vibration IEC 60068-2-6 (Test Fc, Operating)	2 g @ 10...500 Hz
Shock, operating IEC 60068-2-27 (Test Ea, Unpackaged Shock)	30 g
Shock, nonoperating IEC 60068-2-27 (Test Ea, Unpackaged Shock)	50 g
Emissions	CISPR 11: Group 1, Class A
ESD immunity IEC 61000-4-2	6 kV contact discharges 8 kV air discharges
Radiated RF immunity IEC 61000-4-3	10V/m with 1 kHz sine-wave 80% AM from 80... 2000 MHz 10V/m with 200 Hz 50% Pulse 100% AM @ 900 MHz 10V/m with 200 Hz 50% Pulse 100% AM @ 1890 MHz 3V/m with 1 kHz sine-wave 80% AM from 2000...2700 MHz
EFT/B immunity IEC 61000-4-4	±4 kV at 5 kHz on signal ports

Environmental Specifications - 1756-OB16E

Attribute	1756-OB16E
Surge transient immunity IEC 61000-4-5	± 1 kV line-line (DM) and ± 2 kV line-earth (CM) on signal ports
Conducted RF immunity IEC 61000-4-6	10V rms with 1 kHz sine-wave 80% AM from 150 kHz...80 MHz
Oscillatory surge withstand IEEE C37.90.1	3 kV

Certifications - 1756-OB16E

Certification ⁽¹⁾	1756-OB16E
UL	UL Listed Industrial Control Equipment, certified for US and Canada. See UL File E65584.
CSA	CSA Certified Process Control Equipment. See CSA File LR54689C. CSA Certified Process Control Equipment for Class I, Division 2 Group A,B,C,D Hazardous Locations. See CSA File LR69960C.
CE	European Union 2004/108/IEC EMC Directive, compliant with: <ul style="list-style-type: none"> • EN 61326-1; Meas./Control/Lab., Industrial Requirements • EN 61000-6-2; Industrial Immunity • EN 61000-6-4; Industrial Emissions • EN 61131-2; Programmable Controllers (Clause 8, Zone A & B) European Union 2006/95/EC LVD, compliant with: <ul style="list-style-type: none"> • EN 61131-2; Programmable Controllers (Clause 11)
C-Tick	Australian Radiocommunications Act, compliant with: AS/NZS CISPR 11; Industrial Emissions
Ex	European Union 94/9/EC ATEX Directive, compliant with: <ul style="list-style-type: none"> • EN 60079-15; Potentially Explosive Atmospheres, Protection "n" • EN 60079-0; General Requirements II 3 G Ex nA IIC T4 X
FM	FM Approved Equipment for use in Class I Division 2 Group A,B,C,D Hazardous Locations

(1) When marked. See the Product Certification link at <http://www.ab.com> for Declarations of Conformity, Certificates, and other certification details.

1756-OB16I

ControlLogix DC (10...30V) isolated output module

Simplified Schematic

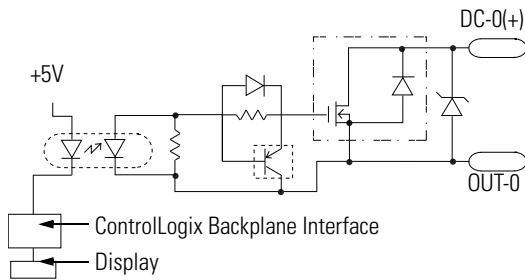

Surge Current Chart

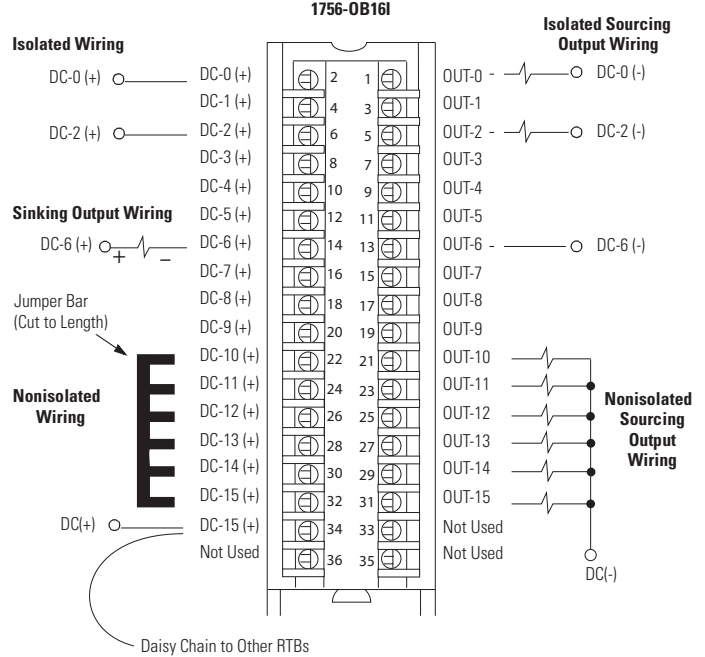
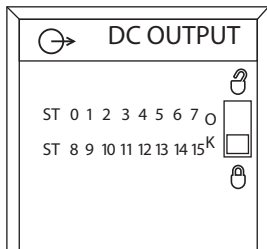
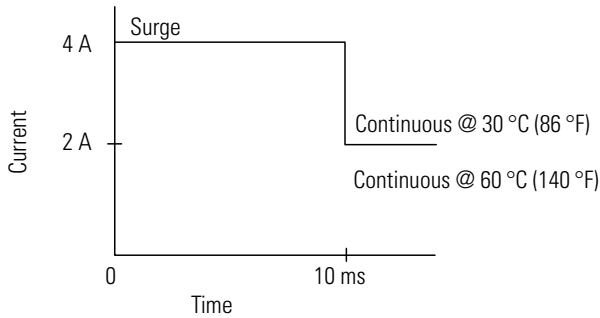

Additional jumper bars are available as cat. no. 1756-JMPR.

Technical Specifications - 1756-OB16I

Attribute	1756-OB16I
Outputs	16 individually isolated
Pilot duty	2 A (DC-13SQ)
Voltage category	12/24V DC sink/source
Operating voltage range	10...30V DC
Output delay time OFF to ON ON to OFF	1 ms max 2 ms max
Current draw @ 5.1V	350 mA
Current draw @ 24V	2.5 mA
Total backplane power	1.8 W
Power dissipation, max	3.6 W @ 60 °C (140 °F)
Thermal dissipation	12.28 BTU/hr
Off-state leakage current per point, max	0.5 mA per point
On-state voltage drop, max	1.2V DC @ 2 A
Current per point, max	2 A @ 30 °C (86 °F) 1 A @ 60 °C (140 °F) (linear derating)
Current per module, max	8 A @ 30 °C (86 °F) 4 A @ 60 °C (140 °F) (linear derating)

Technical Specifications - 1756-OB16I

Attribute	1756-OB16I
Surge current per point	4 A for 10 ms per point, repeatable every 2 s
Load current, min	1 mA per point
Scheduled outputs	Synchronization within 16.7 s max, reference to the Coordinated System Time
Fault states per point	Hold last state, on or off (off is default)
States in Program mode per point	Hold last state, on or off (off is default)
Isolation voltage	250V (continuous), basic insulation type, outputs-to-backplane 125V (continuous), basic insulation type, output-to-output Routine tested @ 1350V AC for 2 s
Module keying	Electronic, software configurable
Fusing	Not protected. A fused IFM is recommended to protect outputs
Removable terminal block	1756-TBCH 1756-TBS6H
RTB keying	User-defined mechanical
Slot width	1
Wire category	1 ⁽¹⁾
North American temperature code	T4A
IEC temperature code	T4
Enclosure type	None (open-style)

(1) Use this conductor category information for planning conductor routing as described in the system-level installation manual. See the Industrial Automation Wiring and Grounding Guidelines, publication [1770-4.1](#).

Environmental Specifications - 1756-OB16I

Attribute	1756-OB16I
Temperature, operating IEC 60068-2-1 (Test Ad, Operating Cold), IEC 60068-2-2 (Test Bd, Operating Dry Heat), IEC 60068-2-14 (Test Nb, Operating Thermal Shock)	0...60 °C (32...140 °F)
Temperature, surrounding air, max	60 °C (140 °F)
Temperature, storage IEC 60068-2-1 (Test Ab, Unpackaged Nonoperating Cold), IEC 60068-2-2 (Test Bb, Unpackaged Nonoperating Dry Heat), IEC 60068-2-14 (Test Na, Unpackaged Nonoperating Thermal Shock)	-40...85 °C (-40...185 °F)
Relative humidity IEC 60068-2-30 (Test Db, Unpackaged Nonoperating Damp Heat)	5...95% noncondensing
Vibration IEC 60068-2-6 (Test Fc, Operating)	2 g @ 10...500 Hz
Shock, operating IEC 60068-2-27 (Test Ea, Unpackaged Shock)	30 g
Shock, nonoperating IEC 60068-2-27 (Test Ea, Unpackaged Shock)	50 g
Emissions	CISPR 11: Group 1, Class A
ESD immunity IEC 61000-4-2	6 kV contact discharges 8 kV air discharges

Environmental Specifications - 1756-OB16I

Attribute	1756-OB16I
Radiated RF immunity IEC 61000-4-3	10V/m with 1 kHz sine-wave 80% AM from 80... 2000 MHz 10V/m with 200 Hz 50% Pulse 100% AM @ 900 MHz 10V/m with 200 Hz 50% Pulse 100% AM @ 1890 MHz 3V/m with 1 kHz sine-wave 80% AM from 2000...2700 MHz
EFT/B immunity IEC 61000-4-4	±4 kV at 5 kHz on signal ports
Surge transient immunity IEC 61000-4-5	±1 kV line-line (DM) and ±2 kV line-earth (CM) on signal ports
Conducted RF immunity IEC 61000-4-6	10V rms with 1 kHz sine-wave 80% AM from 150 kHz...80 MHz

Certifications - 1756-OB16I

Certification ⁽¹⁾	1756-OB16I
UL	UL Listed Industrial Control Equipment, certified for US and Canada. See UL File E65584.
CSA	CSA Certified Process Control Equipment. See CSA File LR54689C. CSA Certified Process Control Equipment for Class I, Division 2 Group A,B,C,D Hazardous Locations. See CSA File LR69960C.
CE	European Union 2004/108/IEC EMC Directive, compliant with: <ul style="list-style-type: none"> • EN 61326-1; Meas./Control/Lab., Industrial Requirements • EN 61000-6-2; Industrial Immunity • EN 61000-6-4; Industrial Emissions • EN 61131-2; Programmable Controllers (Clause 8, Zone A & B) European Union 2006/95/EC LVD, compliant with: <ul style="list-style-type: none"> • EN 61131-2; Programmable Controllers (Clause 11)
C-Tick	Australian Radiocommunications Act, compliant with: AS/NZS CISPR 11; Industrial Emissions
Ex	European Union 94/9/EC ATEX Directive, compliant with: <ul style="list-style-type: none"> • EN 60079-15; Potentially Explosive Atmospheres, Protection "n" • EN 60079-0; General Requirements II 3 G Ex nA IIC T4 X
FM	FM Approved Equipment for use in Class I Division 2 Group A,B,C,D Hazardous Locations
TÜV	TÜV Certified for Functional Safety ⁽²⁾ . Capable of SIL 2

(1) When marked. See the Product Certification link at <http://www.ab.com> for Declarations of Conformity, Certificates, and other certification details.

(2) When used with specified firmware revisions and in accordance with application guidelines described in Using ControlLogix in SIL2 Applications Safety Reference Manual, publication [1756-RM001](#).

1756-OB16IS

ControlLogix DC (10...30V) scheduled, isolated output module

Simplified Schematic

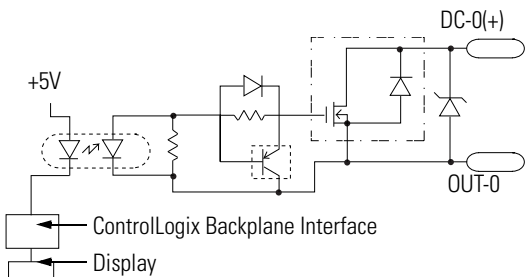

Surge Current Chart

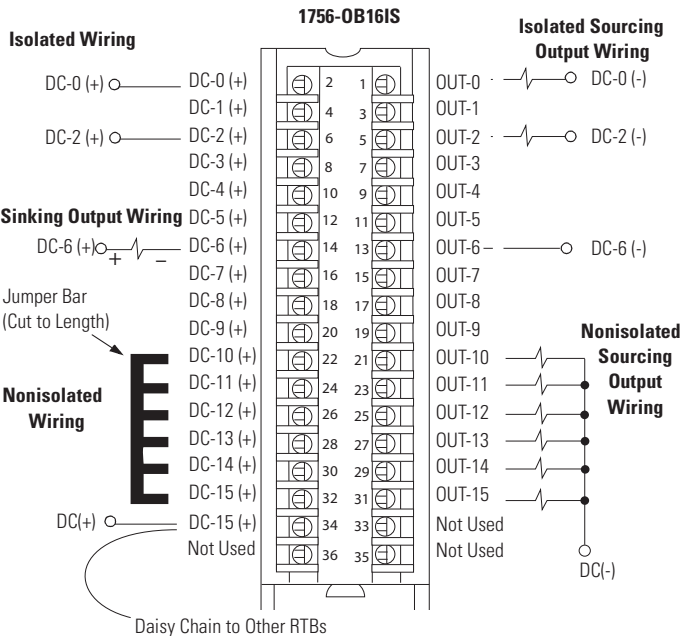
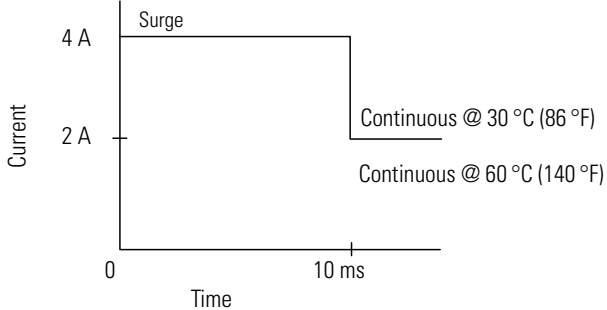

Additional jumper bars are available as cat. no. 1756-JMPR.

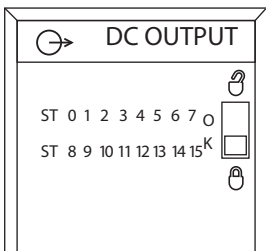

Technical Specifications - 1756-OB16IS

Attribute	1756-OB16IS
Outputs	16 individually isolated, 8 scheduled
Pilot duty	2 A (DC-13SQ)
Voltage category	12/24V DC sink/source
Operating voltage range	10...30V DC
Output delay time OFF to ON ON to OFF	1 ms max 2 ms max
Current draw @ 5.1V	350 mA
Current draw @ 24V	2.5 mA
Total backplane power	1.8 W
Power dissipation, max	3.6 W @ 60 °C (140 °F)
Thermal dissipation	12.28 BTU/hr
Off-state leakage current per point, max	0.5 mA per point
On-state voltage drop, max	1.2V DC @ 2 A
Current per point, max	2 A @ 30 °C (86 °F) 1 A @ 60 °C (140 °F) (linear derating)
Current per module, max	8 A @ 30 °C (86 °F) 4 A @ 60 °C (140 °F) (linear derating)
Surge current per point	4 A for 10 ms per point, repeatable every 2 s

Technical Specifications - 1756-OB16IS

Attribute	1756-OB16IS
Load current, min	1 mA per point
Scheduled outputs	Synchronization within 16.7 s max, reference to the Coordinated System Time
Fault states per point	Hold last state, on or off (off is default)
States in Program mode per point	Hold last state, on or off (off is default)
Isolation voltage	250V (continuous), basic insulation type, outputs-to-backplane, and output-to-output Routine tested @ 1350V AC for 2 s
Module keying	Electronic, software configurable
Fusing	Not protected. A fused IFM can be used to protect outputs. See publication 1492-TD008 . However, the ControlLogix system has been agency certified using only the ControlLogix RTBs, that is, 1756-TBCH, 1756-TBNH, 1756-TBSH, and 1756-TBS6H. Any application that requires agency certification of the ControlLogix system using other wiring termination methods may require application-specific approval by the certifying agency.
Removable terminal block	1756-TBCH 1756-TBS6H
RTB keying	User-defined mechanical
Slot width	1
Wire category	1 ⁽¹⁾
Wire type	Copper
North American temperature code	T4A
IEC temperature code	T4
Enclosure type	None (open-style)

(1) Use this conductor category information for planning conductor routing as described in the system-level installation manual. See the Industrial Automation Wiring and Grounding Guidelines, publication [1770-4.1](#).

Environmental Specifications - 1756-OB16IS

Attribute	1756-OB16IS
Temperature, operating IEC 60068-2-1 (Test Ad, Operating Cold), IEC 60068-2-2 (Test Bd, Operating Dry Heat), IEC 60068-2-14 (Test Nb, Operating Thermal Shock)	0...60 °C (32...140 °F)
Temperature, surrounding air, max	60 °C (140 °F)
Temperature, storage IEC 60068-2-1 (Test Ab, Unpackaged Nonoperating Cold), IEC 60068-2-2 (Test Bb, Unpackaged Nonoperating Dry Heat), IEC 60068-2-14 (Test Na, Unpackaged Nonoperating Thermal Shock)	-40...85 °C (-40...185 °F)
Relative humidity IEC 60068-2-30 (Test Db, Unpackaged Nonoperating Damp Heat)	5...95% noncondensing
Vibration IEC 60068-2-6 (Test Fc, Operating)	2 g @ 10...500 Hz
Shock, operating IEC 60068-2-27 (Test Ea, Unpackaged Shock)	30 g
Shock, nonoperating IEC 60068-2-27 (Test Ea, Unpackaged Shock)	50 g
Emissions	CISPR 11: Group 1, Class A

Environmental Specifications - 1756-OB16IS

Attribute	1756-OB16IS
ESD immunity IEC 61000-4-2	6 kV contact discharges 8 kV air discharges
Radiated RF immunity IEC 61000-4-3	10V/m with 1 kHz sine-wave 80% AM from 80... 2000 MHz 10V/m with 200 Hz 50% Pulse 100% AM @ 900 MHz 10V/m with 200 Hz 50% Pulse 100% AM @ 1890 MHz 3V/m with 1 kHz sine-wave 80% AM from 2000...2700 MHz
EFT/B immunity IEC 61000-4-4	±4 kV at 5 kHz on signal ports
Surge transient immunity IEC 61000-4-5	±1 kV line-line (DM) and ±2 kV line-earth (CM) on signal ports
Conducted RF immunity IEC 61000-4-6	10V rms with 1 kHz sine-wave 80% AM from 150 kHz...80 MHz

Certifications - 1756-OB16IS

Certification⁽¹⁾	1756-OB16IS
UL	UL Listed Industrial Control Equipment, certified for US and Canada. See UL File E65584.
CSA	CSA Certified Process Control Equipment. See CSA File LR54689C. CSA Certified Process Control Equipment for Class I, Division 2 Group A,B,C,D Hazardous Locations. See CSA File LR69960C.
CE	European Union 2004/108/IEC EMC Directive, compliant with: <ul style="list-style-type: none"> • EN 61326-1; Meas./Control/Lab., Industrial Requirements • EN 61000-6-2; Industrial Immunity • EN 61000-6-4; Industrial Emissions • EN 61131-2; Programmable Controllers (Clause 8, Zone A & B) European Union 2006/95/EC LVD, compliant with: <ul style="list-style-type: none"> • EN 61131-2; Programmable Controllers (Clause 11)
C-Tick	Australian Radiocommunications Act, compliant with: AS/NZS CISPR 11; Industrial Emissions
Ex	European Union 94/9/EC ATEX Directive, compliant with: <ul style="list-style-type: none"> • EN 60079-15; Potentially Explosive Atmospheres, Protection "n" • EN 60079-0; General Requirements II 3 G Ex nA IIC T4 X

(1) When marked. See the Product Certification link at <http://www.ab.com> for Declarations of Conformity, Certificates, and other certification details.

1756-OB32

ControlLogix DC (10...31.2V) output module

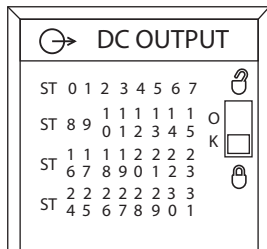
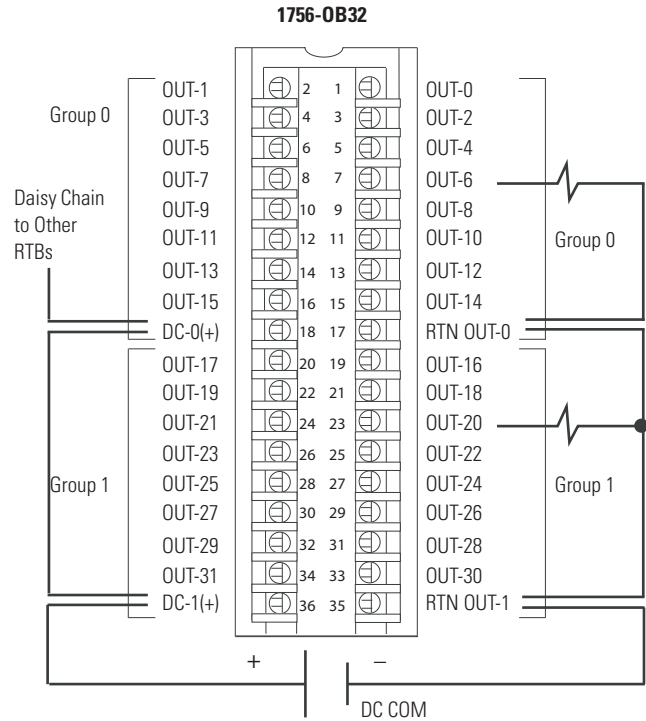
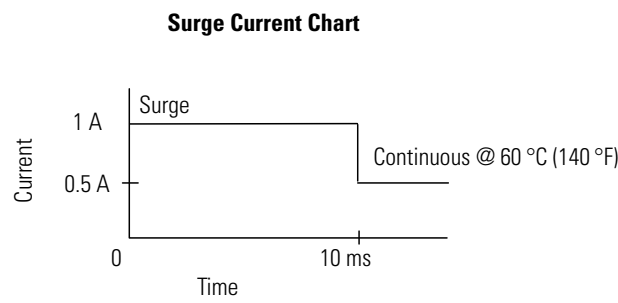
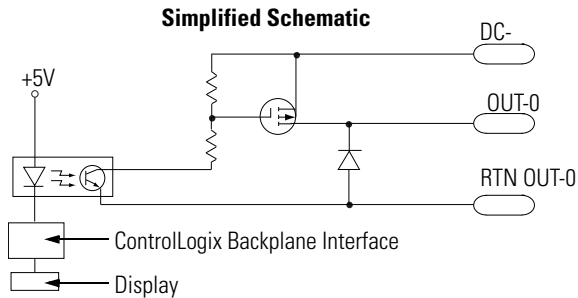

Technical Specifications - 1756-OB32

Attribute	1756-OB32
Outputs	32 (16 points/group)
Voltage category	12/24V DC source
Operating voltage range	10...31.2V DC
Output delay time OFF to ON ON to OFF	60 μs nom/1 ms max 200 μs nom/1 ms max
Current draw @ 5.1V	300 mA
Current draw @ 24V	2 mA
Total backplane power	1.58 W
Power dissipation, max	4.8 W @ 60 °C (140 °F)
Thermal dissipation	16.37 BTU/hr
Off-state leakage current per point, max	0.5 mA per point
On-state voltage drop, max	200 mV DC @ 0.5 A
Current per point, max	0.5 A @ 50 °C (122 °F) linear derating 0.35 A @ 60 °C (140 °F)
Current per module, max	16 A @ 50 °C (122 °F) linear derating 10 A @ 60 °C (140 °F)
Surge current per point, max	1 A for 10 ms per point, repeatable every 2 s @ 60 °C (140 °F)
Load current, min	3 mA per point

Technical Specifications - 1756-OB32

Attribute	1756-OB32
Scheduled outputs	Synchronization within 16.7 s max, reference to the Coordinated System Time
Fault states per point	Hold last state, on or off (off is default)
States in Program mode per point	Hold last state, on or off (off is default)
Isolation voltage	250V (continuous), basic insulation type, outputs-to-backplane, and output group-to-group No isolation between individual group outputs Routine tested @ 1350V AC for 2 s
Module keying	Electronic, software configurable
Fusing	Not protected. A fused IFM can be used to protect outputs. See publication 1492-TD008 . However, the ControlLogix system has been agency certified using only the ControlLogix RTBs, that is, 1756-TBCH, 1756-TBNH, 1756-TBSH, and 1756-TBS6H. Any application that requires agency certification of the ControlLogix system using other wiring termination methods may require application-specific approval by the certifying agency.
Removable terminal block	1756-TBCH 1756-TBS6H
RTB keying	User-defined mechanical
Slot width	1
Wire category	1 ⁽¹⁾
North American temperature code	T3C
IEC temperature code	T3
Enclosure type	None (open-style)

(1) Use this conductor category information for planning conductor routing as described in the system-level installation manual. See the Industrial Automation Wiring and Grounding Guidelines, publication [1770-4.1](#).

Environmental Specifications - 1756-OB32

Attribute	1756-OB32
Temperature, operating IEC 60068-2-1 (Test Ad, Operating Cold), IEC 60068-2-2 (Test Bd, Operating Dry Heat), IEC 60068-2-14 (Test Nb, Operating Thermal Shock)	0...60 °C (32...140 °F)
Temperature, surrounding air, max	60 °C (140 °F)
Temperature, storage IEC 60068-2-1 (Test Ab, Unpackaged Nonoperating Cold), IEC 60068-2-2 (Test Bb, Unpackaged Nonoperating Dry Heat), IEC 60068-2-14 (Test Na, Unpackaged Nonoperating Thermal Shock)	-40...85 °C (-40...185 °F)
Relative humidity IEC 60068-2-30 (Test Db, Unpackaged Nonoperating Damp Heat)	5...95% noncondensing
Vibration IEC 60068-2-6 (Test Fc, Operating)	2 g @ 10...500 Hz
Shock, operating IEC 60068-2-27 (Test Ea, Unpackaged Shock)	30 g
Shock, nonoperating IEC 60068-2-27 (Test Ea, Unpackaged Shock)	50 g
Emissions	CISPR 11: Group 1, Class A
ESD immunity IEC 61000-4-2	6 kV contact discharges 8 kV air discharges

Environmental Specifications - 1756-OB32

Attribute	1756-OB32
Radiated RF immunity IEC 61000-4-3	10V/m with 1 kHz sine-wave 80% AM from 80... 2000 MHz 10V/m with 200 Hz 50% Pulse 100% AM @ 900 MHz 10V/m with 200 Hz 50% Pulse 100% AM @ 1890 MHz 3V/m with 1 kHz sine-wave 80% AM from 2000...2700 MHz
EFT/B immunity IEC 61000-4-4	±4 kV at 5 kHz on signal ports
Surge transient immunity IEC 61000-4-5	±1 kV line-line (DM) and ±2 kV line-earth (CM) on signal ports
Conducted RF immunity IEC 61000-4-6	10V rms with 1 kHz sine-wave 80% AM from 150 kHz...80 MHz

Certifications - 1756-OB32

Certification ⁽¹⁾	1756-OB32
UL	UL Listed Industrial Control Equipment, certified for US and Canada. See UL File E65584.
CSA	CSA Certified Process Control Equipment. See CSA File LR54689C. CSA Certified Process Control Equipment for Class I, Division 2 Group A,B,C,D Hazardous Locations. See CSA File LR69960C.
CE	European Union 2004/108/IEC EMC Directive, compliant with: <ul style="list-style-type: none"> • EN 61326-1; Meas./Control/Lab., Industrial Requirements • EN 61000-6-2; Industrial Immunity • EN 61000-6-4; Industrial Emissions • EN 61131-2; Programmable Controllers (Clause 8, Zone A & B) European Union 2006/95/EC LVD, compliant with: <ul style="list-style-type: none"> • EN 61131-2; Programmable Controllers (Clause 11)
C-Tick	Australian Radiocommunications Act, compliant with: AS/NZS CISPR 11; Industrial Emissions
Ex	European Union 94/9/EC ATEX Directive, compliant with: <ul style="list-style-type: none"> • EN 60079-15; Potentially Explosive Atmospheres, Protection "n" • EN 60079-0; General Requirements II 3 G Ex nA IIC T3 X
FM	FM Approved Equipment for use in Class I Division 2 Group A,B,C,D Hazardous Locations
TÜV	TÜV Certified for Functional Safety ⁽²⁾ . Capable of SIL 2

(1) When marked. See the Product Certification link at <http://www.ab.com> for Declarations of Conformity, Certificates, and other certification details.

(2) When used with specified firmware revisions and in accordance with application guidelines described in Using ControlLogix in SIL2 Applications Safety Reference Manual, publication [1756-RM001](#).

1756-OC8

ControlLogix DC (30...60V) output module

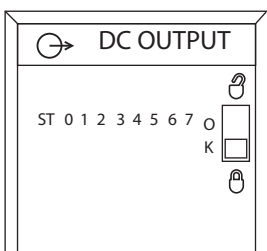
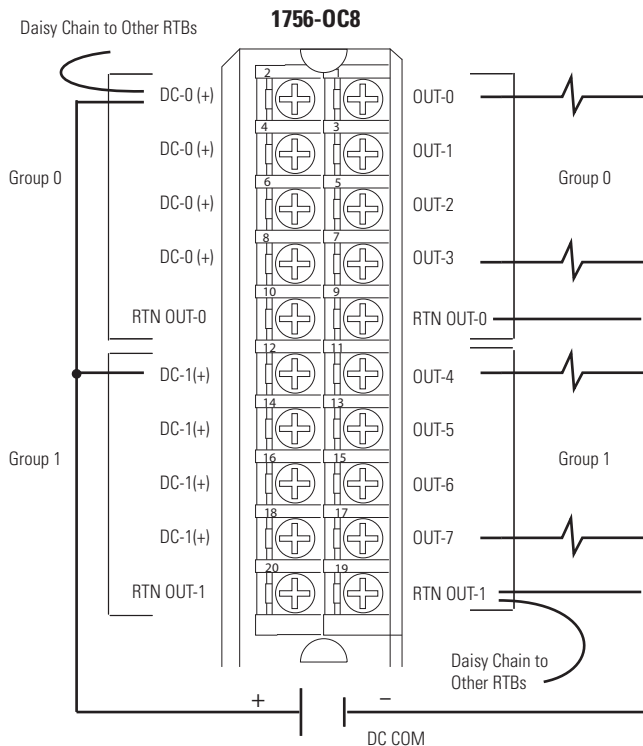
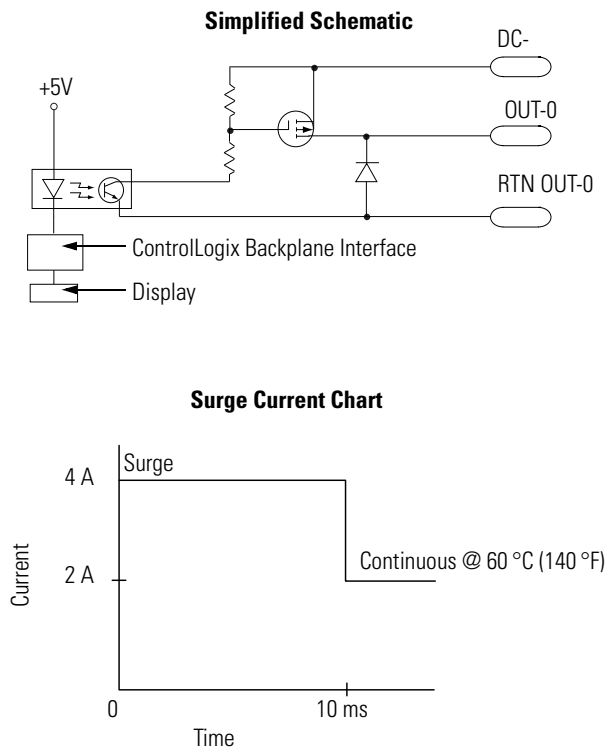

Technical Specifications - 1756-OC8

Attribute	1756-OC8
Outputs	8 (4 points/group)
Pilot duty	2 A
Voltage category	48V DC source
Operating voltage range	30...60V DC
Output delay time OFF to ON ON to OFF	1 ms max 2 ms max
Current draw @ 5.1V	165 mA
Current draw @ 24V	2 mA
Total backplane power	0.89 W
Power dissipation, max	4.9 W @ 60 °C (140 °F)
Thermal dissipation	16.71 BTU/hr
Off-state leakage current, max	1 mA per point
On-state voltage drop, max	2V DC @ 2 A
Current per point, max	2 A @ 60 °C (140 °F)
Current per module, max	8 A @ 60 °C (140 °F)
Surge current per point	4 A for 10 ms per point, repeatable every 1 s @ 60 °C (140 °F)

Technical Specifications - 1756-OC8

Attribute	1756-OC8
Load current, min	2 mA per point
Scheduled outputs	Synchronization within 16.7 s max, reference to the Coordinated System Time
Fault states per point	Hold last state, on or off (off is default)
States in Program mode per point	Hold last state, on or off (off is default)
Isolation voltage	250V (continuous), basic insulation type, outputs-to-backplane, and output group-to-group No isolation between individual group outputs Routine tested at 1350V AC for 2 s
Module keying	Electronic, software configurable
Fusing	Not protected. A fused IFM is recommended to protect outputs
Removable terminal block	1756-TBNH 1756-TBSH
RTB keying	User-defined mechanical
Slot width	1
Wire category	1 ⁽¹⁾
North American temperature code	T4
IEC temperature code	T4
Enclosure type	None (open-style)

(1) Use this conductor category information for planning conductor routing as described in the system-level installation manual. See the Industrial Automation Wiring and Grounding Guidelines, publication [1770-4.1](#).

Environmental Specifications - 1756-OC8

Attribute	1756-OC8
Temperature, operating IEC 60068-2-1 (Test Ad, Operating Cold), IEC 60068-2-2 (Test Bd, Operating Dry Heat), IEC 60068-2-14 (Test Nb, Operating Thermal Shock)	0...60 °C (32...140 °F)
Temperature, surrounding air, max	60 °C (140 °F)
Temperature, storage IEC 60068-2-1 (Test Ab, Unpackaged Nonoperating Cold), IEC 60068-2-2 (Test Bb, Unpackaged Nonoperating Dry Heat), IEC 60068-2-14 (Test Na, Unpackaged Nonoperating Thermal Shock)	-40...85 °C (-40...185 °F)
Relative humidity IEC 60068-2-30 (Test Db, Unpackaged Nonoperating Damp Heat)	5...95% noncondensing
Vibration IEC 60068-2-6 (Test Fc, Operating)	2 g @ 10...500 Hz
Shock, operating IEC 60068-2-27 (Test Ea, Unpackaged Shock)	30 g
Shock, nonoperating IEC 60068-2-27 (Test Ea, Unpackaged Shock)	50 g
Emissions	CISPR 11: Group 1, Class A
ESD immunity IEC 61000-4-2	6 kV contact discharges 8 kV air discharges
Radiated RF immunity IEC 61000-4-3	10V/m with 1 kHz sine-wave 80% AM from 80... 2000 MHz 10V/m with 200 Hz 50% Pulse 100% AM @ 900 MHz 10V/m with 200 Hz 50% Pulse 100% AM @ 1890 MHz 3V/m with 1 kHz sine-wave 80% AM from 2000...2700 MHz

Environmental Specifications - 1756-OC8

Attribute	1756-OC8
EFT/B immunity IEC 61000-4-4	±4 kV at 5 kHz on signal ports
Surge transient immunity IEC 61000-4-5	±1 kV line-line (DM) and ±2 kV line-earth (CM) on signal ports
Conducted RF immunity IEC 61000-4-6	10V rms with 1 kHz sine-wave 80% AM from 150 kHz...80 MHz

Certifications - 1756-OC8

Certification ⁽¹⁾	1756-OC8
UL	UL Listed Industrial Control Equipment, certified for US and Canada. See UL File E65584.
CSA	CSA Certified Process Control Equipment. See CSA File LR54689C. CSA Certified Process Control Equipment for Class I, Division 2 Group A,B,C,D Hazardous Locations. See CSA File LR69960C.
CE	European Union 2004/108/IEC EMC Directive, compliant with: <ul style="list-style-type: none"> • EN 61326-1; Meas./Control/Lab., Industrial Requirements • EN 61000-6-2; Industrial Immunity • EN 61000-6-4; Industrial Emissions • EN 61131-2; Programmable Controllers (Clause 8, Zone A & B) European Union 2006/95/EC LVD, compliant with: <ul style="list-style-type: none"> • EN 61131-2; Programmable Controllers (Clause 11)
C-Tick	Australian Radiocommunications Act, compliant with: AS/NZS CISPR 11; Industrial Emissions
Ex	European Union 94/9/EC ATEX Directive, compliant with: <ul style="list-style-type: none"> • EN 60079-15; Potentially Explosive Atmospheres, Protection "n" • EN 60079-0; General Requirements II 3 G Ex nA IIC T4 X
FM	FM Approved Equipment for use in Class I Division 2 Group A,B,C,D Hazardous Locations

(1) When marked. See the Product Certification link at <http://www.ab.com> for Declarations of Conformity, Certificates, and other certification details.

1756-OF4

ControlLogix voltage/current output analog module

1756-OF4 Current

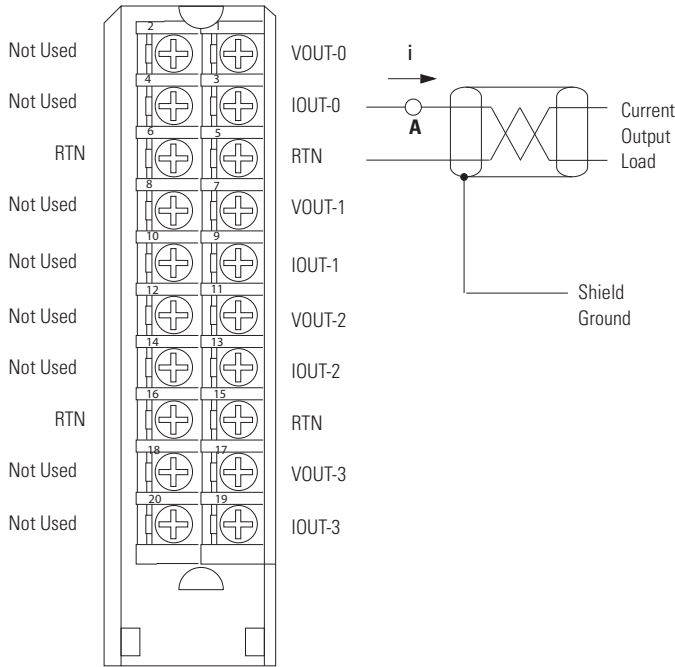

1756-OF4 Voltage

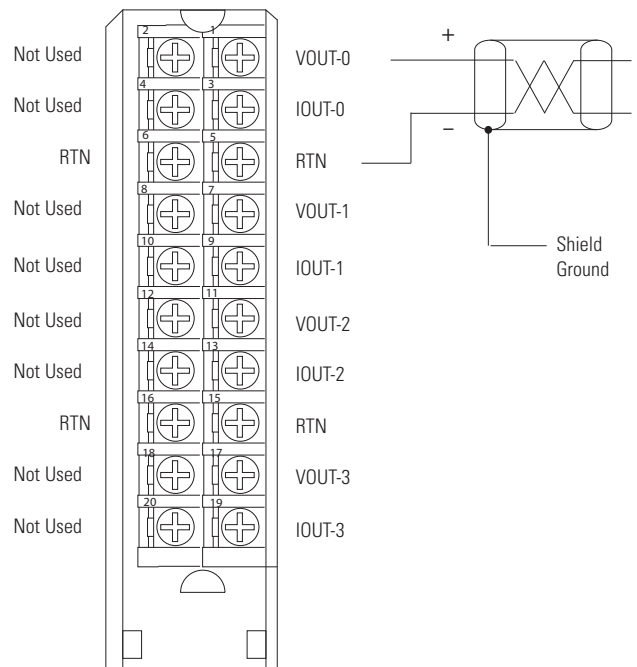

- Place additional loop devices (such as strip chart recorders) at the A location noted above.
- All terminals marked RTN are connected internally.

- All terminals marked RTN are connected internally.

Signal and User Counts - 1756-OF4

Range	Low Signal and User Counts	High Signal and User Counts
0...20 mA	0 mA -32768 counts	21.2916 mA 32767 counts
±10V	-10.4336V -32768 counts	10.4336V 32767 counts

Technical Specifications - 1756-OF4

Attribute	1756-OF4
Outputs	4 voltage or current outputs
Output range	±10.4V 0...21 mA
Resolution	Voltage: 15 bits across 10.5V, 320 µV/bit Current: 15 bits across 21mA, 650 nA/bit
Current draw @ 5.1V	150 mA
Current draw @ 24V	120 mA

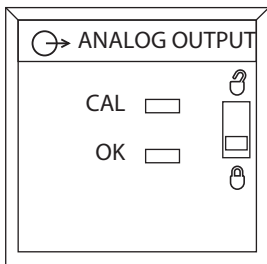

Technical Specifications - 1756-OF4

Attribute	1756-OF4
Total backplane power	5.8 W
Power dissipation, max	3.25 W, 4 channel current
Thermal dissipation	10.91 BTU/hr
Open circuit detection	Current output only (Output must be set to >0.1 mA)
Overvoltage protection	24V DC
Short circuit protection	Electronically current limited to 21mA or less
Drive capability	Voltage: >2000 Ω Current: 0...750 Ω
Settling time	<2 ms to 95% of final value with resistive loads
Calibrated accuracy	Better than 0.05% of range from 4...21 mA, -10.4...10.4V
Calibration interval	12 months typical
Offset drift	50 $\mu\text{V}/^\circ\text{C}$ 100 $\text{nA}/^\circ\text{C}$
Gain drift with temperature	Voltage: 25 ppm/ $^\circ\text{C}$, 520 $\mu\text{V}/^\circ\text{C}$ Current: 50 ppm/ $^\circ\text{C}$, 1050 $\mu\text{A}/^\circ\text{C}$
Module error	Voltage: 0.15% of range Current: 0.3% of range
Module scan time	12 ms floating point 8 ms integer
Data format	Integer mode (left justified, 2s complement) IEEE 32-bit floating point
Module conversion method	R-Ladder DAC, monotonicity with no missing codes
Isolation voltage	250V (continuous), reinforced insulation type, output channels-to-backplane No isolation between individual output channels Routine tested at 1350V AC for 2 s
Module keying	Electronic, software configurable
Removable terminal block	1756-TBNH 1756-TBSH
RTB keying	User-defined mechanical
Slot width	1
Wire category	2 ⁽¹⁾
North American temperature code	T4A
IEC temperature code	T4
Enclosure type	None (open-style)

(1) Use this conductor category information for planning conductor routing as described in the system-level installation manual. See the Industrial Automation Wiring and Grounding Guidelines, publication [1770-4.1](#).

Environmental Specifications - 1756-OF4

Attribute	1756-OF4
Temperature, operating IEC 60068-2-1 (Test Ad, Operating Cold), IEC 60068-2-2 (Test Bd, Operating Dry Heat), IEC 60068-2-14 (Test Nb, Operating Thermal Shock)	0...60 °C (32...140 °F)
Temperature, surrounding air, max	60 °C (140 °F)
Temperature, storage IEC 60068-2-1 (Test Ab, Unpackaged Nonoperating Cold), IEC 60068-2-2 (Test Bb, Unpackaged Nonoperating Dry Heat), IEC 60068-2-14 (Test Na, Unpackaged Nonoperating Thermal Shock)	-40...85 °C (-40...185 °F)
Relative humidity IEC 60068-2-30 (Test Db, Unpackaged Nonoperating Damp Heat)	5...95% noncondensing
Vibration IEC 60068-2-6 (Test Fc, Operating)	2 g @ 10...500 Hz
Shock, operating IEC 60068-2-27 (Test Ea, Unpackaged Shock)	30 g
Shock, nonoperating IEC 60068-2-27 (Test Ea, Unpackaged Shock)	50 g
Emissions	CISPR 11: Group 1, Class A
ESD immunity IEC 61000-4-2	6 kV contact discharges 8 kV air discharges
Radiated RF immunity IEC 61000-4-3	10V/m with 1 kHz sine-wave 80% AM from 80...2000 MHz 10V/m with 200 Hz 50% Pulse 100% AM @ 900 MHz 10V/m with 200 Hz 50% Pulse 100% AM @ 1890 MHz 3V/m with 1 kHz sine-wave 80% AM from 2000...2700 MHz
EFT/B immunity IEC 61000-4-4	±2 kV at 5 kHz on shielded signal ports
Surge transient immunity IEC 61000-4-5	±2 kV line-earth (CM) on shielded signal ports
Conducted RF immunity IEC 61000-4-6	10V rms with 1 kHz sine-wave 80% AM from 150 kHz...80 MHz on shielded signal ports

Certifications - 1756-OF4

Certification ⁽¹⁾	1756-OF4
UL	UL Listed Industrial Control Equipment, certified for US and Canada. See UL File E65584.
CSA	CSA Certified Process Control Equipment. See CSA File LR54689C. CSA Certified Process Control Equipment for Class I, Division 2 Group A,B,C,D Hazardous Locations. See CSA File LR69960C.
CE	European Union 2004/108/IEC EMC Directive, compliant with: <ul style="list-style-type: none"> • EN 61326-1; Meas./Control/Lab., Industrial Requirements • EN 61000-6-2; Industrial Immunity • EN 61000-6-4; Industrial Emissions • EN 61131-2; Programmable Controllers (Clause 8, Zone A & B) European Union 2006/95/EC LVD, compliant with: <ul style="list-style-type: none"> • EN 61131-2; Programmable Controllers (Clause 11)
C-Tick	Australian Radiocommunications Act, compliant with: AS/NZS CISPR 11; Industrial Emissions
Ex	European Union 94/9/EC ATEX Directive, compliant with: <ul style="list-style-type: none"> • EN 60079-15; Potentially Explosive Atmospheres, Protection "n" • EN 60079-0; General Requirements II 3 G Ex nA IIC T4 X
FM	FM Approved Equipment for use in Class I Division 2 Group A,B,C,D Hazardous Locations

(1) When marked. See the Product Certification link at <http://www.ab.com> for Declarations of Conformity, Certificates, and other certification details.

1756-OF6CI

ControlLogix current loop output analog module

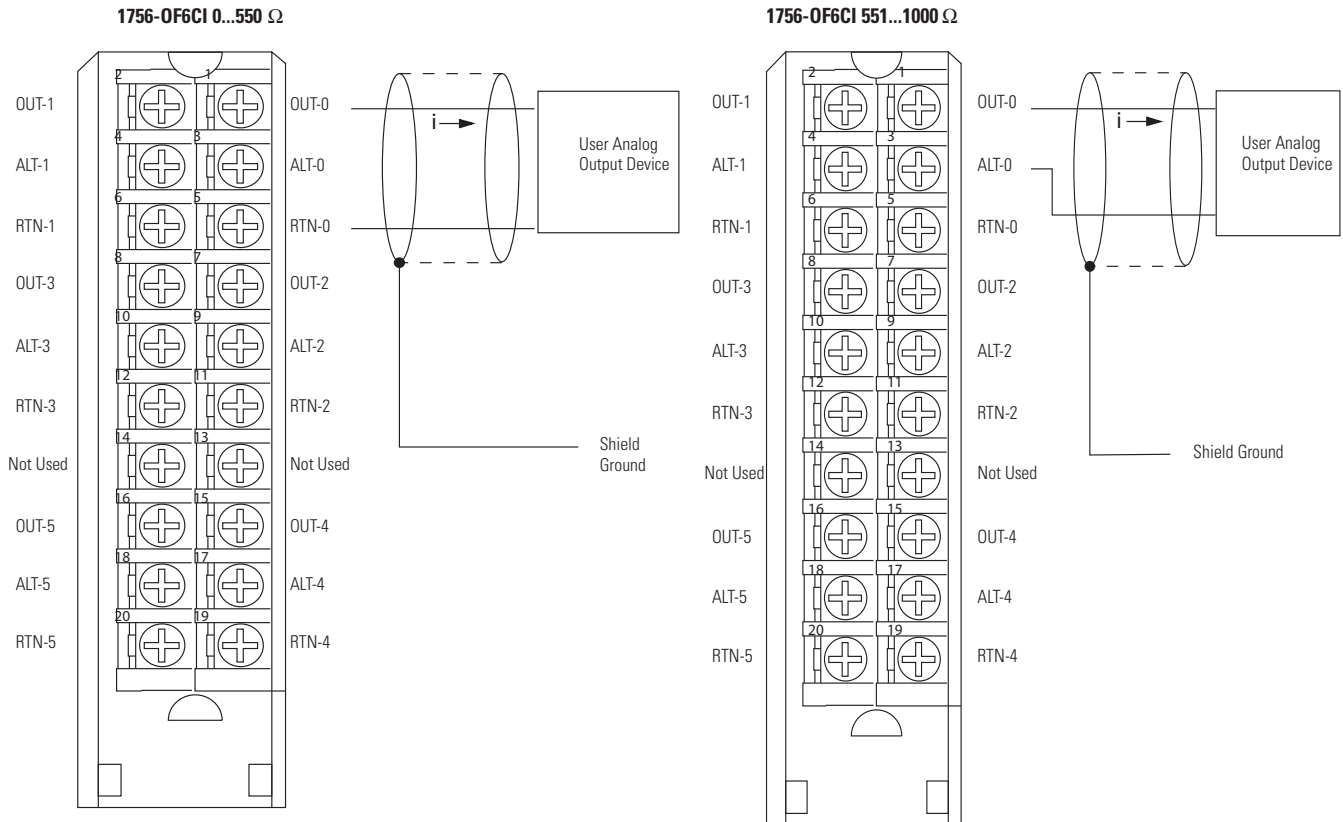

Place additional devices anywhere in the loop.

Place additional devices anywhere in the loop.

Signal and User Counts - 1756-OF6CI

Range	Low Signal and User Counts	High Signal and User Counts
0...20 mA	0 mA -32768 counts	21.074 mA 32767 counts

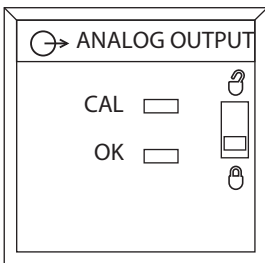

Technical Specifications - 1756-OF6CI

Attribute	1756-OF6CI
Outputs	6 individually isolated
Output range	0...21 mA
Resolution	13 bits across 21 mA (2.7 μA)
Current draw @ 5.1V	250 mA for 0...550 Ω loads terminated on OUTs and RTNs 250 mA for 551...1000 Ω loads terminated on OUTs and ALTs
Current draw @ 24V	225 mA for 0...550 Ω loads terminated on OUTs and RTNs 300 mA for 551...1000 Ω loads terminated on OUTs and ALTs
Total backplane power	6.7 W for 0...550 Ω range 8.5 W for 551...1000 Ω range

Technical Specifications - 1756-OF6CI

Attribute	1756-OF6CI
Power dissipation, max	5.5 W (0...550 Ω loads) 6.1 W (551...1000 Ω loads)
Thermal dissipation	18.76 BTU/hr (0...550 Ω loads) 20.80 BTU/hr (551...1000 Ω loads)
Open circuit detection	None
Overvoltage protection	24V DC
Short circuit protection	Electronically current limited to 21 mA or less
Drive capability	0...1000 Ω Separate field terminations for 0...550 Ω and 551...1000 Ω
Settling time	< 2 ms to 95% of final value with resistive loads
Calibrated accuracy @ 25 °C (77 °F)	Better than 0.1% of range from 4...21 mA
Calibration interval	6 months typical
Offset drift	1 μ A/°C typical
Gain drift with temperature, nom	60 ppm/°C
Gain drift with temperature, max	100 ppm/°C
Module error	0.6% of range
Module scan time, max	25 ms floating point 10 ms integer
Data format	Integer mode (left justified, 2s complement) IEEE 32-bit floating point
Module conversion method	R-Ladder DAC, monotonicity with no missing codes
Isolation voltage	250V (continuous), basic insulation type, output channels-to-backplane, and output channel-to-channel Routine tested at 1350V AC for 2 s
Module keying	Electronic, software configurable
Removable terminal block	1756-TBNH 1756-TBSH
RTB keying	User-defined mechanical
Slot width	1
Wire category	2 ⁽¹⁾
North American temperature code	T4A
IEC temperature code	T4
Enclosure type	None (open-style)

(1) Use this conductor category information for planning conductor routing as described in the system-level installation manual. See the Industrial Automation Wiring and Grounding Guidelines, publication [1770-4.1](#).

Environmental Specifications - 1756-OF6CI

Attribute	1756-OF6CI
Temperature, operating IEC 60068-2-1 (Test Ad, Operating Cold), IEC 60068-2-2 (Test Bd, Operating Dry Heat), IEC 60068-2-14 (Test Nb, Operating Thermal Shock)	0...60 °C (32...140 °F)
Temperature, surrounding air, max	60 °C (140 °F)
Temperature, storage IEC 60068-2-1 (Test Ab, Unpackaged Nonoperating Cold), IEC 60068-2-2 (Test Bb, Unpackaged Nonoperating Dry Heat), IEC 60068-2-14 (Test Na, Unpackaged Nonoperating Thermal Shock)	-40...85 °C (-40...185 °F)

Environmental Specifications - 1756-OF6CI

Attribute	1756-OF6CI
Relative humidity IEC 60068-2-30 (Test Db, Unpackaged Nonoperating Damp Heat)	5...95% noncondensing
Vibration IEC 60068-2-6 (Test Fc, Operating)	2 g @ 10...500 Hz
Shock, operating IEC 60068-2-27 (Test Ea, Unpackaged Shock)	30 g
Shock, nonoperating IEC 60068-2-27 (Test Ea, Unpackaged Shock)	50 g
Emissions	CISPR 11: Group 1, Class A
ESD immunity IEC 61000-4-2	6 kV contact discharges 8 kV air discharges
Radiated RF immunity IEC 61000-4-3	10V/m with 1 kHz sine-wave 80% AM from 80... 2000 MHz 10V/m with 200 Hz 50% Pulse 100% AM @ 900 MHz 10V/m with 200 Hz 50% Pulse 100% AM @ 1890 MHz 3V/m with 1 kHz sine-wave 80% AM from 2000...2700 MHz
EFT/B immunity IEC 61000-4-4	±2 kV at 5 kHz on shielded signal ports
Surge transient immunity IEC 61000-4-5	±2 kV line-earth (CM) on shielded signal ports
Conducted RF immunity IEC 61000-4-6	10V rms with 1 kHz sine-wave 80% AM from 150 kHz...80 MHz on shielded signal ports

Certifications - 1756-OF6CI

Certification ⁽¹⁾	1756-OF6CI
UL	UL Listed Industrial Control Equipment, certified for US and Canada. See UL File E65584.
CSA	CSA Certified Process Control Equipment. See CSA File LR54689C. CSA Certified Process Control Equipment for Class I, Division 2 Group A,B,C,D Hazardous Locations. See CSA File LR69960C.
CE	European Union 2004/108/IEC EMC Directive, compliant with: <ul style="list-style-type: none"> • EN 61326-1; Meas./Control/Lab., Industrial Requirements • EN 61000-6-2; Industrial Immunity • EN 61000-6-4; Industrial Emissions • EN 61131-2; Programmable Controllers (Clause 8, Zone A & B) European Union 2006/95/EC LVD, compliant with: <ul style="list-style-type: none"> • EN 61131-2; Programmable Controllers (Clause 11)
C-Tick	Australian Radiocommunications Act, compliant with: AS/NZS CISPR 11; Industrial Emissions
Ex	European Union 94/9/EC ATEX Directive, compliant with: <ul style="list-style-type: none"> • EN 60079-15; Potentially Explosive Atmospheres, Protection "n" • EN 60079-0; General Requirements II 3 G Ex nA IIC T4 X
FM	FM Approved Equipment for use in Class I Division 2 Group A,B,C,D Hazardous Locations
TÜV	TÜV Certified for Functional Safety ⁽²⁾ . Capable of SIL 2

(1) When marked. See the Product Certification link at <http://www.ab.com> for Declarations of Conformity, Certificates, and other certification details.

(2) When used with specified firmware revisions and in accordance with application guidelines described in Using ControlLogix in SIL2 Applications Safety Reference Manual, publication [1756-RM001](#).

1756-OF6VI

ControlLogix voltage loop output analog module

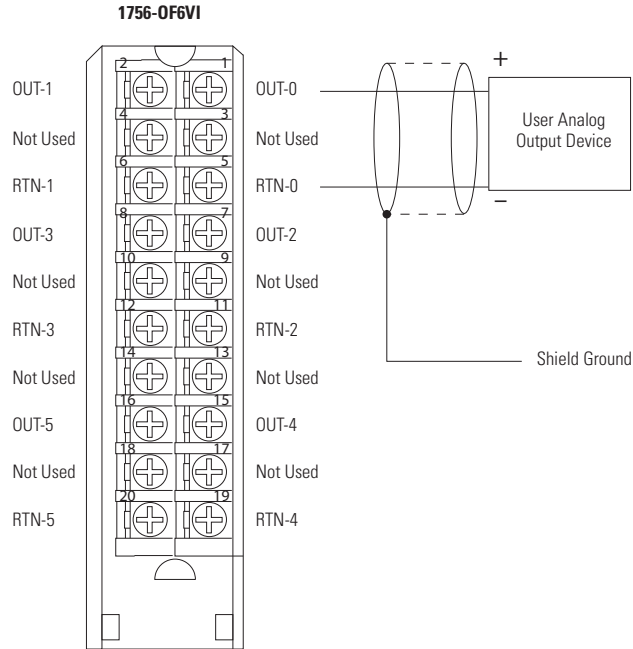

Place additional devices anywhere in the loop.

Signal and User Counts - 1756-OF6VI

Range	Low Signal and User Counts	High Signal and User Counts
±10V	-10.517V -32768 counts	10.517V 32767 counts

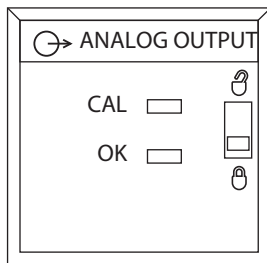

Technical Specifications - 1756-OF6VI

Attribute	1756-OF6VI
Outputs	6 individually isolated
Output range	± 10.5V
Resolution	14 bits across 21V (1.3 mV) (13 bits across 10.5V +sign bit)
Current draw @ 5.1V	250 mA
Current draw @ 24V	175 mA
Total backplane power	5.5 W
Power dissipation, max	4.85 W
Thermal dissipation	16.54 BTU/hr
Output impedance	<1 Ω
Open circuit detection	None
Overvoltage protection	24V DC
Short circuit protection	Electronically current limited

Technical Specifications - 1756-OF6VI

Attribute	1756-OF6VI
Drive capability	> 1000 Ω loads, 10 mA
Settling time	< 2 ms to 95% of final value with resistive loads
Calibrated accuracy @ 25 °C (77 °F)	Better than 0.1% of range
Calibration interval	6 months typical
Offset drift	60 μ V/ °C typical
Gain drift with temperature, nom	50 ppm/°C
Gain drift with temperature, max	80 ppm/°C
Module error	0.5% of range
Module scan time, max	25 ms floating point 10 ms integer
Data format	Integer mode (left justified, 2s complement) IEEE 32-bit floating point
Module conversion method	R-Ladder DAC, monotonicity with no missing codes
Isolation voltage	250V (continuous), basic insulation type, output channels-to-backplane, and output channel-to-channel Routine tested at 1350V AC for 2 s
Module keying	Electronic, software configurable
Removable terminal block	1756-TBNH 1756-TBSH
RTB keying	User-defined mechanical
Slot width	1
Wire category	2 ⁽¹⁾
North American temperature code	T4A
IEC temperature code	T4
Enclosure	None (open-style)

(1) Use this conductor category information for planning conductor routing as described in the system-level installation manual. See the Industrial Automation Wiring and Grounding Guidelines, publication [1770-4.1](#).

Environmental Specifications - 1756-OF6VI

Attribute	1756-OF6VI
Temperature, operating IEC 60068-2-1 (Test Ad, Operating Cold), IEC 60068-2-2 (Test Bd, Operating Dry Heat), IEC 60068-2-14 (Test Nb, Operating Thermal Shock)	0...60 °C (32...140 °F)
Temperature, surrounding air, max	60 °C (140 °F)
Temperature, storage IEC 60068-2-1 (Test Ab, Unpackaged Nonoperating Cold), IEC 60068-2-2 (Test Bb, Unpackaged Nonoperating Dry Heat), IEC 60068-2-14 (Test Na, Unpackaged Nonoperating Thermal Shock)	-40...85 °C (-40...185 °F)
Relative humidity IEC 60068-2-30 (Test Db, Unpackaged Nonoperating Damp Heat)	5...95% noncondensing
Vibration IEC 60068-2-6 (Test Fc, Operating)	2 g @ 10...500 Hz
Shock, operating IEC 60068-2-27 (Test Ea, Unpackaged Shock)	30 g
Shock, nonoperating IEC 60068-2-27 (Test Ea, Unpackaged Shock)	50 g

Environmental Specifications - 1756-OF6VI

Attribute	1756-OF6VI
Emissions	CISPR 11: Group 1, Class A
ESD immunity IEC 61000-4-2	6 kV contact discharges 8 kV air discharges
Radiated RF immunity IEC 61000-4-3	10V/m with 1 kHz sine-wave 80% AM from 80... 2000 MHz 10V/m with 200 Hz 50% Pulse 100% AM @ 900 MHz 10V/m with 200 Hz 50% Pulse 100% AM @ 1890 MHz 3V/m with 1 kHz sine-wave 80% AM from 2000...2700 MHz
EFT/B immunity IEC 61000-4-4	±2 kV at 5 kHz on shielded signal ports
Surge transient immunity IEC 61000-4-5	±2 kV line-earth (CM) on shielded signal ports
Conducted RF Immunity IEC 61000-4-6	10V rms with 1 kHz sine-wave 80% AM from 150 kHz...80 MHz on shielded signal ports

Certifications - 1756-OF6VI

Certification ⁽¹⁾	1756-OF6VI
UL	UL Listed Industrial Control Equipment, certified for US and Canada. See UL File E65584.
CSA	CSA Certified Process Control Equipment. See CSA File LR54689C. CSA Certified Process Control Equipment for Class I, Division 2 Group A,B,C,D Hazardous Locations. See CSA File LR69960C.
CE	European Union 2004/108/IEC EMC Directive, compliant with: <ul style="list-style-type: none"> • EN 61326-1; Meas./Control/Lab., Industrial Requirements • EN 61000-6-2; Industrial Immunity • EN 61000-6-4; Industrial Emissions • EN 61131-2; Programmable Controllers (Clause 8, Zone A & B) European Union 2006/95/EC LVD, compliant with: <ul style="list-style-type: none"> • EN 61131-2; Programmable Controllers (Clause 11)
C-Tick	Australian Radiocommunications Act, compliant with: AS/NZS CISPR 11; Industrial Emissions
Ex	European Union 94/9/EC ATEX Directive, compliant with: <ul style="list-style-type: none"> • EN 60079-15; Potentially Explosive Atmospheres, Protection "n" • EN 60079-0; General Requirements II 3 G Ex nA IIC T4 X
FM	FM Approved Equipment for use in Class I Division 2 Group A,B,C,D Hazardous Locations
TÜV	TÜV Certified for Functional Safety ⁽²⁾ : Capable of SIL 2

(1) When marked. See the Product Certification link at <http://www.ab.com> for Declarations of Conformity, Certificates, and other certification details.

(2) When used with specified firmware revisions and in accordance with application guidelines described in Using ControlLogix in SIL2 Applications Safety Reference Manual, publication [1756-RM001](#).

1756-OF8

ControlLogix voltage/current output analog module

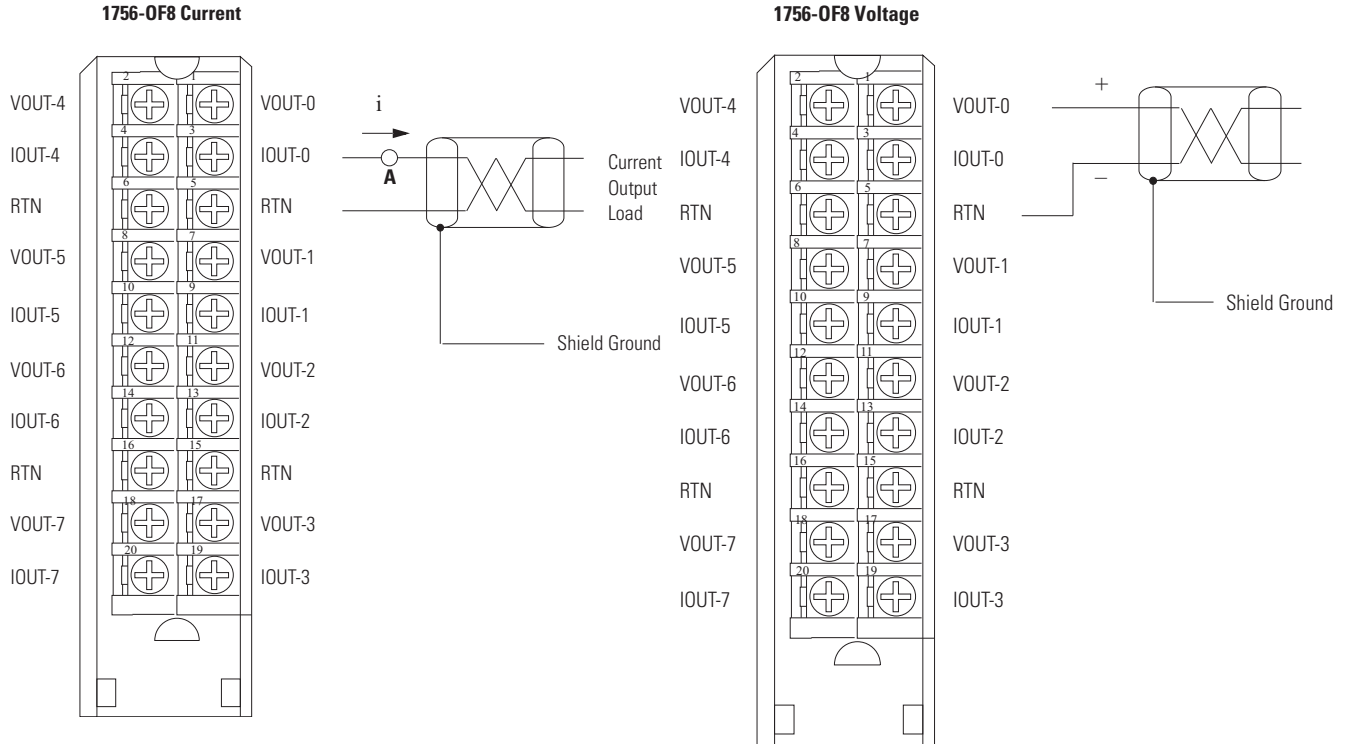

- Place additional loop devices (such as strip chart recorders) at the A location noted above.
- All terminals marked RTN are connected internally.

Signal and User Counts - 1756-OF8

Range	Low Signal and User Counts	High Signal and User Counts
0...20 mA	0 mA -32768 counts	21.2916 mA 32767 counts
±10V	-10.4336V -32768 counts	10.4336V 32767 counts

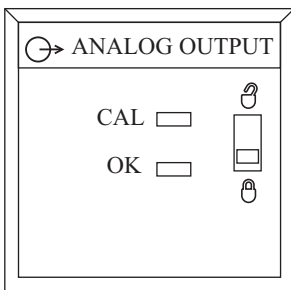

Technical Specifications - 1756-OF8

Attribute	1756-OF8
Outputs	8 voltage or current
Output range	± 10.4V 0...21 mA
Resolution	15 bits across 21 mA - 650 nA/bit 15 bits across 10.4V - 320 μV/bit
Current draw @ 5.1V	150 mA
Current draw @ 24V	210 mA

Technical Specifications - 1756-OF8

Attribute	1756-OF8
Total backplane power	5.8 W
Power dissipation, max	4.92 W, 8 channel current
Thermal dissipation	16.78 BTU/hr
Open circuit detection	Current output only (Output must be set to >0.1 mA)
Overvoltage protection	24V DC
Short circuit protection	Electronically current limited to 21 mA or less
Drive capability	Voltage: > 2000 Ω Current: 0...750 Ω
Settling time	< 2 ms to 95% of final value with resistive loads
Calibrated accuracy @ 25 °C (77 °F)	Better than 0.05% of range from 4...21 mA, -10.4...10.4V
Calibration interval	12 months typical
Offset drift	50 μ V/°C typical (Voltage mode) 0.1 μ A/°C typical (Current mode)
Gain drift with temperature, max	Voltage: 25 ppm/°C max Current: 50 ppm/°C max
Module error	Voltage: 0.15% of range Current: 0.3% of range
Module scan time, min	12 ms floating point 8 ms integer
Data format	Integer mode (left justified, 2s complement) IEEE 32-bit floating point
Module conversion method	R-Ladder DAC, monotonicity with no missing codes
Isolation voltage	250V (continuous), reinforced insulation type, output channels-to-backplane No isolation between individual output channels Routine tested at 1350V AC for 2 s
Module keying	Electronic, software configurable
Removable terminal block	1756-TBNH 1756-TBSH
RTB keying	User-defined mechanical
Slot width	1
Wire category	2 ⁽¹⁾
North American temperature code	T4A
IEC temperature code	T4
Enclosure type	None (open-style)

(1) Use this conductor category information for planning conductor routing as described in the system-level installation manual. See the Industrial Automation Wiring and Grounding Guidelines, publication [1770-4.1](#).

Environmental Specifications - 1756-OF8

Attribute	1756-OF8
Temperature, operating IEC 60068-2-1 (Test Ad, Operating Cold), IEC 60068-2-2 (Test Bd, Operating Dry Heat), IEC 60068-2-14 (Test Nb, Operating Thermal Shock)	0...60 °C (32...140 °F)
Temperature, surrounding air, max	60 °C (140 °F)
Temperature, storage IEC 60068-2-1 (Test Ab, Unpackaged Nonoperating Cold), IEC 60068-2-2 (Test Bb, Unpackaged Nonoperating Dry Heat), IEC 60068-2-14 (Test Na, Unpackaged Nonoperating Thermal Shock)	-40...85 °C (-40...185 °F)
Relative humidity IEC 60068-2-30 (Test Db, Unpackaged Nonoperating Damp Heat)	5...95% noncondensing
Vibration IEC 60068-2-6 (Test Fc, Operating)	2 g @ 10...500 Hz
Shock, operating IEC 60068-2-27 (Test Ea, Unpackaged Shock)	30 g
Shock, nonoperating IEC 60068-2-27 (Test Ea, Unpackaged Shock)	50 g
Emissions	CISPR 11: Group 1, Class A
ESD immunity IEC 61000-4-2	6 kV contact discharges 8 kV air discharges
Radiated RF immunity IEC 61000-4-3	10V/m with 1 kHz sine-wave 80% AM from 80...2000 MHz 10V/m with 200 Hz 50% Pulse 100% AM @ 900 MHz 10V/m with 200 Hz 50% Pulse 100% AM @ 1890 MHz 3V/m with 1 kHz sine-wave 80% AM from 2000...2700 MHz
EFT/B immunity IEC 61000-4-4	±2 kV at 5 kHz on shielded signal ports
Surge transient immunity IEC 61000-4-5	±2 kV line-earth (CM) on shielded signal ports
Conducted RF immunity IEC 61000-4-6	10V rms with 1 kHz sine-wave 80% AM from 150 kHz...80 MHz on shielded signal ports

Certifications - 1756-OF8

Certification⁽¹⁾	1756-OF8
UL	UL Listed Industrial Control Equipment, certified for US and Canada. See UL File E65584.
CSA	CSA Certified Process Control Equipment. See CSA File LR54689C. CSA Certified Process Control Equipment for Class I, Division 2 Group A,B,C,D Hazardous Locations. See CSA File LR69960C.
CE	European Union 2004/108/IEC EMC Directive, compliant with: <ul style="list-style-type: none"> • EN 61326-1; Meas./Control/Lab., Industrial Requirements • EN 61000-6-2; Industrial Immunity • EN 61000-6-4; Industrial Emissions • EN 61131-2; Programmable Controllers (Clause 8, Zone A & B) European Union 2006/95/EC LVD, compliant with: <ul style="list-style-type: none"> • EN 61131-2; Programmable Controllers (Clause 11)
C-Tick	Australian Radiocommunications Act, compliant with: AS/NZS CISPR 11; Industrial Emissions
Ex	European Union 94/9/EC ATEX Directive, compliant with: <ul style="list-style-type: none"> • EN 60079-15; Potentially Explosive Atmospheres, Protection "n" • EN 60079-0; General Requirements II 3 G Ex nA IIC T4 X
FM	FM Approved Equipment for use in Class I Division 2 Group A,B,C,D Hazardous Locations
TÜV	TÜV Certified for Functional Safety ⁽²⁾ : Capable of SIL 2

(1) When marked. See the Product Certification link at <http://www.ab.com> for Declarations of Conformity, Certificates, and other certification details.

(2) When used with specified firmware revisions and in accordance with application guidelines described in Using ControlLogix in SIL2 Applications Safety Reference Manual, publication [1756-RM001](#).

1756-OF8H

ControlLogix voltage/current output analog module with HART protocol

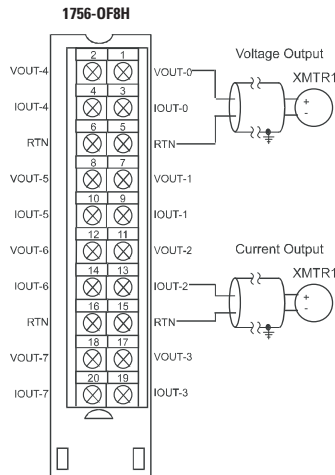

Signal and User Counts - 1756-OF8H

Range	Low Signal and User Counts	High Signal and User Counts
0...20 mA	0 mA -32768 counts	21.2916 mA 32767 counts
±10V	-10.4336V -32768 counts	10.4336V 32767 counts

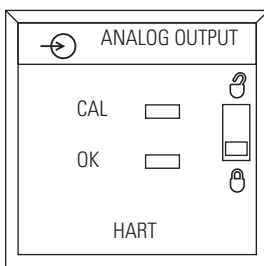

Technical Specifications - 1756-OF8H

Attribute	1756-OF8H
Outputs	8 voltage or current
Output range	±10.4V 0...20 mA 4...20 mA
Resolution	15...16 bits
Current draw @ 5V	200 mA
Current draw @ 24V	230 mA
Total backplane power	6.54 W
Power dissipation, max	4.92 W, 8 channel current
Thermal dissipation	16.78 BTU/hr
Output impedance	Voltage: >2 kΩ @ 10.4V Current: 50...750 Ω drive
Open circuit detection time	Current output only (output must be set to < 0.1mA)
Overvoltage protection, max	±24V DC
Drive capability	Voltage: > 2000 Ω @ 10.4V Current: 50...750 Ω with short circuit survival current
Load reactance, max	Voltage: 1 μF Current: 10 μH

Technical Specifications - 1756-OF8H

Attribute	1756-OF8H
Settling time	Current (no HART): < 23 ms to 95% with resistive loads Current (with HART): < 37 ms to 95% with resistive loads Voltage: < 8.5 ms to 95% with resistive loads
Calibrated accuracy @ 25 °C (77 °F)	Voltage: Better than 0.05% of range Current: Better than 0.15% of range
Calibration interval	12 months typical
Offset drift	100 μ V/°C typical 200 nA/°C typical
Gain drift with temperature	Voltage: 20 ppm/°C Current: 35 ppm/°C
Module error	Voltage: 0.15% of range Current: 0.3% of range
Module output scan time, min	12 ms floating point
Module HART scan time	Typically 1 s per HART channel enabled Estimate 10 s if all 8 channels have HART enabled Pass through messages, handheld communicators, secondary masters, communication errors, or configuration changes can significantly increase the update time
Data format	Integer mode (left justified, 2s complement) IEEE 32-bit floating point
Input conversion method	Successive approximation
Output conversion method	R-Ladder DAC, monotonicity with no missing codes
Isolation voltage	50V (continuous), basic insulation type, output channels-to-backplane No isolation between individual output channels Type tested at 1500V AC for 60 s
Module keying	Electronic, software configurable
Removable terminal block	1756-TBNH 1756-TBSH
RTB keying	User-defined mechanical
Slot width	1
Wire category	2 ⁽¹⁾
North American temperature code	T4A
IEC temperature code	T4
Enclosure type	None (open-style)

(1) Use this conductor category information for planning conductor routing as described in the system-level installation manual. See the Industrial Automation Wiring and Grounding Guidelines, publication [1770-4.1](#).

Environmental Specifications - 1756-OF8H

Attribute	1756-OF8H
Temperature, operating IEC 60068-2-1 (Test Ad, Operating Cold), IEC 60068-2-2 (Test Bd, Operating Dry Heat), IEC 60068-2-14 (Test Nb, Operating Thermal Shock)	0...60 °C (32...140 °F)
Temperature, surrounding air, max	60 °C (140 °F)
Temperature, storage IEC 60068-2-1 (Test Ab, Unpackaged Nonoperating Cold), IEC 60068-2-2 (Test Bb, Unpackaged Nonoperating Dry Heat), IEC 60068-2-14 (Test Na, Unpackaged Nonoperating Thermal Shock)	-40...85 °C (-40...185 °F)

Environmental Specifications - 1756-OF8H

Attribute	1756-OF8H
Relative humidity IEC 60068-2-30 (Test Db, Unpackaged Nonoperating Damp Heat)	5...95% noncondensing
Vibration IEC 60068-2-6 (Test Fc, Operating)	2 g @ 10...500 Hz
Shock, operating IEC 60068-2-27 (Test Ea, Unpackaged Shock)	30 g
Shock, nonoperating IEC 60068-2-27 (Test Ea, Unpackaged Shock)	50 g
Emissions	CISPR 11: Group 1, Class A
ESD immunity IEC 61000-4-2	6 kV contact discharges 8 kV air discharges
Radiated RF immunity IEC 61000-4-3	10V/m with 1 kHz sine-wave 80% AM from 80... 2000 MHz 10V/m with 200 Hz 50% Pulse 100% AM @ 900 MHz 10V/m with 200 Hz 50% Pulse 100% AM @ 1890 MHz 1V/m with 1 kHz sine-wave 80% AM from 2000...2700 MHz
EFT/B immunity IEC 61000-4-4	±2 kV at 5 kHz on shielded signal ports
Surge transient immunity IEC 61000-4-5	±2 kV line-earth (CM) on shielded signal ports
Conducted RF immunity IEC 61000-4-6	10V rms with 1 kHz sine-wave 80% AM from 150 kHz...80 MHz on shielded signal ports

Certifications - 1756-OF8H

Certification ⁽¹⁾	1756-OF8H
c-UL-us	UL Listed Industrial Control Equipment, certified for US and Canada. See UL File E65584.
CSA	CSA Certified Process Control Equipment for Class I, Division 2 Group A,B,C,D Hazardous Locations. See CSA File LR101622C.
CE	European Union 2004/108/IEC EMC Directive, compliant with: <ul style="list-style-type: none"> • EN 61326-1; Meas./Control/Lab., Industrial Requirements • EN 61000-6-2; Industrial Immunity • EN 61000-6-4; Industrial Emissions • EN 61131-2; Programmable Controllers (Clause 8, Zone A & B)
C-Tick	Australian Radiocommunications Act, compliant with: AS/NZS CISPR 11; Industrial Emissions
Ex	European Union 94/9/EC ATEX Directive, compliant with: <ul style="list-style-type: none"> • EN 60079-15; Potentially Explosive Atmospheres, Protection "n" • EN 60079-0; General Requirements II 3 G Ex nA IIC T4 X
FM	FM Approved Equipment for use in Class I Division 2 Group A,B,C,D Hazardous Locations
TÜV	TÜV Certified for Functional Safety ⁽²⁾ : Capable of SIL 2

(1) When marked. See the Product Certification link at <http://www.ab.com> for Declarations of Conformity, Certificates, and other certification details.

(2) When used with specified firmware revisions and in accordance with application guidelines described in Using ControlLogix in SIL2 Applications Safety Reference Manual, publication [1756-RM001](#).

1756-0G16

ControlLogix TTL output module

Standard Wiring

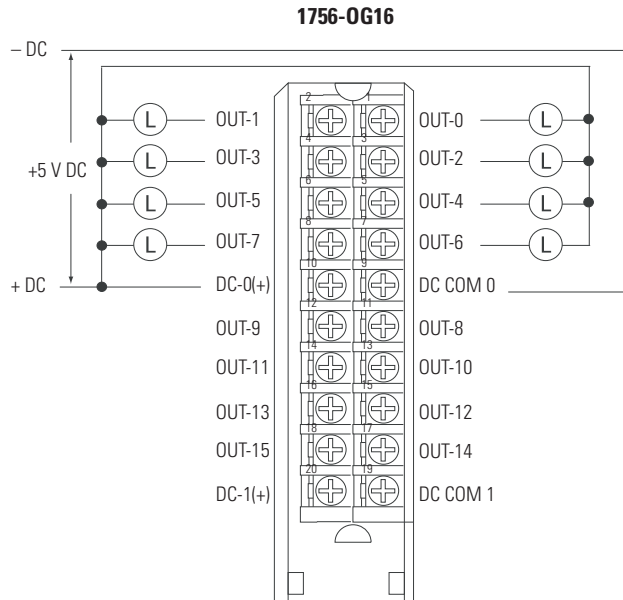

CE Compliant Wiring

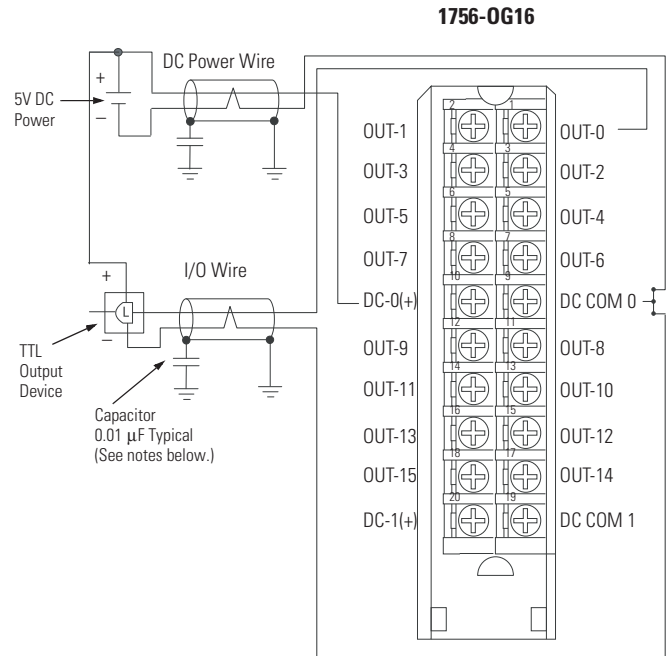

Important: I/O cables must be shielded type and cable length must be <10 m (32.8 ft) for maximum EMI noise immunity.

Simplified Schematic

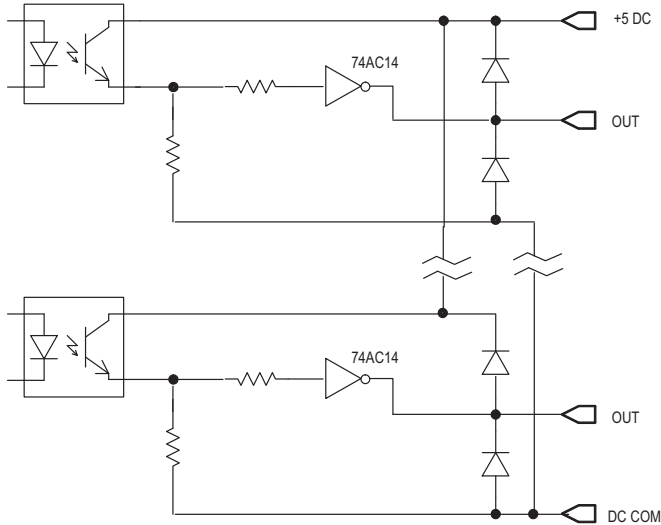

Low to True Format - 1756-0G16

- 0...0.4V DC = Output guaranteed to be in on-state
- 0.4...4.5V DC = Output state not guaranteed
- 4.5...5.5V DC = Output guaranteed to be in off-state

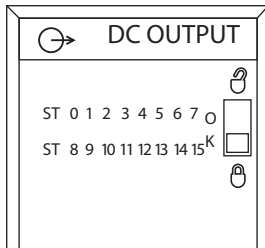

Technical Specifications - 1756-OG16

Attribute	1756-OG16
Outputs	16 (8 points/group)
Voltage category	5V DC TTL (Low=True ⁽¹⁾)
Operating voltage range	4.5...5.5V DC source, 50 mV P-P ripple max
Output delay time (resistive load) OFF to ON (5V-to-0V DC transition) ON to OFF (0V-to-5V DC transition)	45 µs nom/450 µs max 145 µs nom/700 µs max
Current draw @ 5.1V	210 mA
Current draw @ 24V	2 mA
Total backplane power	1.12 W
Power dissipation, max	1.5 W @ 60 °C (140 °F)
Thermal dissipation	5.2 BTU/hr @ 60 °C (140 °F)
Off-state leakage current per point, max	0.1 mA per point
On-state voltage drop, max	0.4V DC
Continuous current, max	24 mA
Load current per point, max	24 mA
Load current per module, max	384 mA
Load current	0.15 mA
Scheduled outputs	Synchronization within 16.7 s max, reference to the Coordinated System Time
Fault states per point	Hold last state, on or off (off is default)
States in Program mode per point	Hold last state, on or off (off is default)
Isolation voltage	250V (continuous), basic insulation type, outputs-to-backplane, and output group-to-group No isolation between individual group outputs Routine tested @ 1350V AC for 2 s
Module keying	Electronic, software configurable
Fusing	Not protected. A fused IFM is recommended to protect outputs
Removable terminal block	1756-TBNH 1756-TBSH
RTB keying	User-defined mechanical
Slot width	1
Wire category	2 ⁽²⁾
North American temperature code	T5
IEC temperature code	T5
Enclosure type	None (open-style)

(1) TTL outputs are inverted (0 to +0.4V dc = low voltage = True = On.) Use a NOT instruction in your program to convert to traditional True - High logic.

(2) Use this conductor category information for planning conductor routing as described in the system-level installation manual. See the Industrial Automation Wiring and Grounding Guidelines, publication [1770-4.1](#).

Environmental Specifications - 1756-OG16

Attribute	1756-OG16
Temperature, operating IEC 60068-2-1 (Test Ad, Operating Cold), IEC 60068-2-2 (Test Bd, Operating Dry Heat), IEC 60068-2-14 (Test Nb, Operating Thermal Shock)	0...60 °C (32...140 °F)
Temperature, surrounding air, max	60 °C (140 °F)
Temperature, storage IEC 60068-2-1 (Test Ab, Unpackaged Nonoperating Cold), IEC 60068-2-2 (Test Bb, Unpackaged Nonoperating Dry Heat), IEC 60068-2-14 (Test Na, Unpackaged Nonoperating Thermal Shock)	-40...85 °C (-40...185 °F)
Relative humidity IEC 60068-2-30 (Test Db, Unpackaged Nonoperating Damp Heat)	5...95% noncondensing
Vibration IEC 60068-2-6 (Test Fc, Operating)	2 g @ 10...500 Hz
Shock, operating IEC 60068-2-27 (Test Ea, Unpackaged Shock)	30 g
Shock, nonoperating IEC 60068-2-27 (Test Ea, Unpackaged Shock)	50 g
Emissions	CISPR 11: Group 1, Class A
ESD immunity IEC 61000-4-2	6 kV contact discharges 8 kV air discharges
Radiated RF immunity IEC 61000-4-3	10V/m with 1 kHz sine-wave 80% AM from 80...2000 MHz 10V/m with 200 Hz 50% Pulse 100% AM @ 900 MHz 10V/m with 200 Hz 50% Pulse 100% AM @ 1890 MHz 3V/m with 1 kHz sine-wave 80% AM from 2000...2700 MHz
EFT/B immunity IEC 61000-4-4	±4 kV at 5 kHz on signal ports
Conducted RF immunity IEC 61000-4-6	10V rms with 1 kHz sine-wave 80% AM from 150 kHz...80 MHz

Certifications - 1756-OG16

Certification ⁽¹⁾	1756-OG16
UL	UL Listed Industrial Control Equipment, certified for US and Canada. See UL File E65584.
CSA	CSA Certified Process Control Equipment. See CSA File LR54689C. CSA Certified Process Control Equipment for Class I, Division 2 Group A,B,C,D Hazardous Locations. See CSA File LR69960C.
CE	European Union 2004/108/IEC EMC Directive, compliant with: <ul style="list-style-type: none"> • EN 61326-1; Meas./Control/Lab., Industrial Requirements • EN 61000-6-2; Industrial Immunity • EN 61000-6-4; Industrial Emissions • EN 61131-2; Programmable Controllers (Clause 8, Zone A & B)
C-Tick	Australian Radiocommunications Act, compliant with: AS/NZS CISPR 11; Industrial Emissions
Ex	European Union 94/9/EC ATEX Directive, compliant with: <ul style="list-style-type: none"> • EN 60079-15; Potentially Explosive Atmospheres, Protection "n" • EN 60079-0; General Requirements II 3 G Ex nA IIC T5 X

(1) When marked. See the Product Certification link at <http://www.ab.com> for Declarations of Conformity, Certificates, and other certification details.

1756-OH8I

ControlLogix DC (90...146V) isolated output module

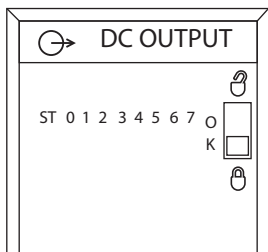
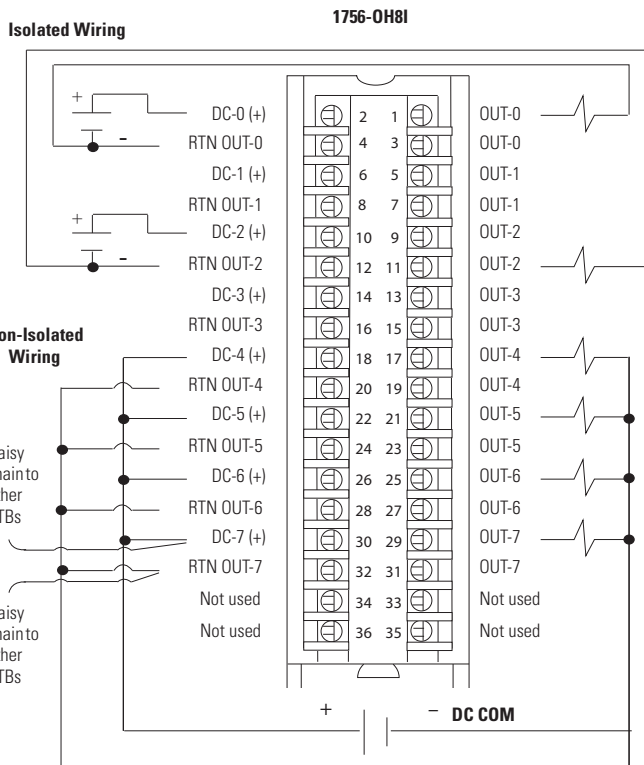
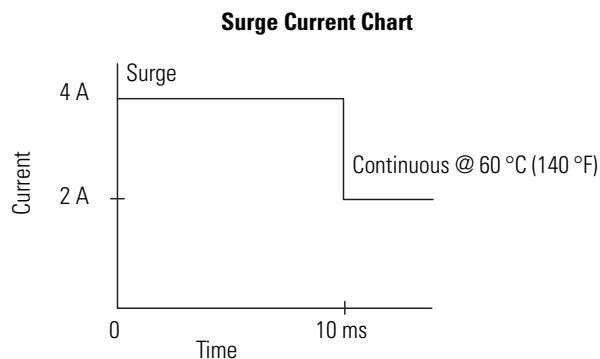
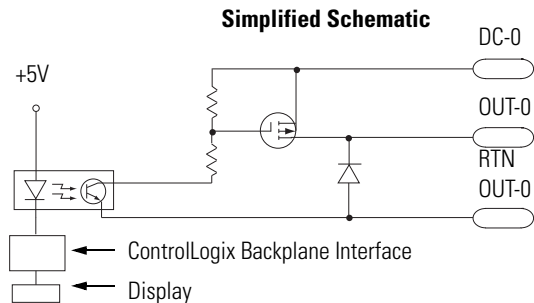

Technical Specifications - 1756-OH8I

Attribute	1756-OH8I
Outputs	8 individually isolated
Voltage category	120V DC sink/source
Operating voltage range	90...146V DC
Output delay time OFF to ON ON to OFF	2 ms max 2 ms max
Current draw @ 5.1V	210 mA
Current draw @ 24V	2 mA
Total backplane power	1.11 W
Power dissipation, max	3.3 W @ 60 °C (140 °F)
Thermal dissipation	11.25 BTU/hr
Off-state leakage current, max	1 mA per point
On-state voltage drop, max	2V DC @ 2 A
Current per point, max	2 A @ 60 °C (140 °F)
Current per module, max	8 A @ 60 °C (140 °F)
Surge current per point	4 A for 10 ms per point, repeatable every 1 s @ 60 °C (140 °F)

Technical Specifications - 1756-OH8I

Attribute	1756-OH8I
Load current, min	2 mA per point
Scheduled outputs	Synchronization within 16.7 s max, reference to the Coordinated System Time
Fault states per point	Hold last state, on or off (off is default)
States in Program mode per point	Hold last state, on or off (off is default)
Isolation voltage	250V (continuous), basic insulation type, outputs-to-backplane, and output-to-output Routine tested @ 1350V AC for 2 s
Module keying	Electronic, software configurable
Fusing	Not protected. A fused IFM is recommended to protect outputs
Removable terminal block	1756-TBCH 1756-TBS6H
RTB keying	User-defined mechanical
Slot width	1
Wire category	1 ⁽¹⁾
North American temperature code	T4A
Enclosure type	None (open-style)

(1) Use this conductor category information for planning conductor routing as described in the system-level installation manual. See the Industrial Automation Wiring and Grounding Guidelines, publication [1770-4.1](#).

Environmental Specifications - 1756-OH8I

Attribute	1756-OH8I
Temperature, operating IEC 60068-2-1 (Test Ad, Operating Cold), IEC 60068-2-2 (Test Bd, Operating Dry Heat), IEC 60068-2-14 (Test Nb, Operating Thermal Shock)	0...60 °C (32...140 °F)
Temperature, surrounding air, max	60 °C (140 °F)
Temperature, storage IEC 60068-2-1 (Test Ab, Unpackaged Nonoperating Cold), IEC 60068-2-2 (Test Bb, Unpackaged Nonoperating Dry Heat), IEC 60068-2-14 (Test Na, Unpackaged Nonoperating Thermal Shock)	-40...85 °C (-40...185 °F)
Relative humidity IEC 60068-2-30 (Test Db, Unpackaged Nonoperating Damp Heat)	5...95% noncondensing
Vibration IEC 60068-2-6 (Test Fc, Operating)	2 g @ 10...500 Hz
Shock, operating IEC 60068-2-27 (Test Ea, Unpackaged Shock)	30 g
Shock, nonoperating IEC 60068-2-27 (Test Ea, Unpackaged Shock)	50 g
Emissions	CISPR 11: Group 1, Class A
ESD immunity IEC 61000-4-2	6 kV contact discharges 8 kV air discharges
Radiated RF immunity IEC 61000-4-3	10V/m with 1 kHz sine-wave 80% AM from 80... 2000 MHz 10V/m with 200 Hz 50% Pulse 100% AM @ 900 MHz 10V/m with 200 Hz 50% Pulse 100% AM @ 1890 MHz 1V/m with 1 kHz sine-wave 80% AM from 2000...2700 MHz

Environmental Specifications - 1756-OH8I

Attribute	1756-OH8I
EFT/B immunity IEC 61000-4-4	±4 kV at 5 kHz on signal ports
Surge transient immunity IEC 61000-4-5	±1 kV line-line (DM) and ±2 kV line-earth (CM) on signal ports
Conducted RF immunity IEC 61000-4-6	10V rms with 1 kHz sine-wave 80% AM from 150 kHz...80 MHz

Certifications - 1756-OH8I

Certification ⁽¹⁾	1756-OH8I
UL	UL Listed Industrial Control Equipment, certified for US and Canada. See UL File E65584.
CSA	CSA Certified Process Control Equipment. See CSA File LR54689C. CSA Certified Process Control Equipment for Class I, Division 2 Group A,B,C,D Hazardous Locations. See CSA File LR69960C.
CE	European Union 2004/108/IEC EMC Directive, compliant with: <ul style="list-style-type: none"> • EN 61326-1; Meas./Control/Lab., Industrial Requirements • EN 61000-6-2; Industrial Immunity • EN 61000-6-4; Industrial Emissions • EN 61131-2; Programmable Controllers (Clause 8, Zone A & B) European Union 2006/95/EC LVD, compliant with: <ul style="list-style-type: none"> • EN 61131-2; Programmable Controllers
C-Tick	Australian Radiocommunications Act, compliant with: AS/NZS CISPR 11; Industrial Emissions
FM	FM Approved Equipment for use in Class I Division 2 Group A,B,C,D Hazardous Locations

(1) When marked. See the Product Certification link at <http://www.ab.com> for Declarations of Conformity, Certificates, and other certification details.

1756-ON8

ControlLogix AC (10...30V) output module

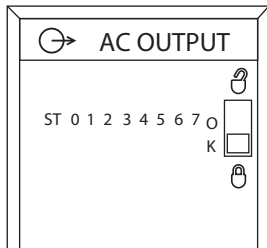
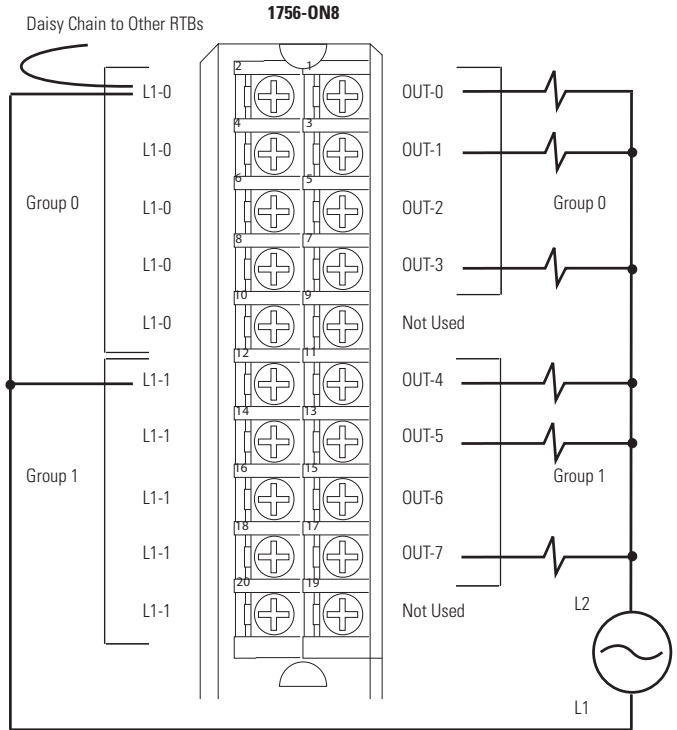
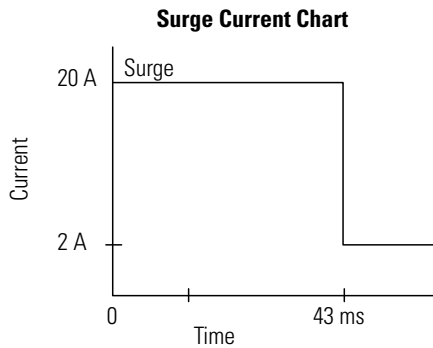
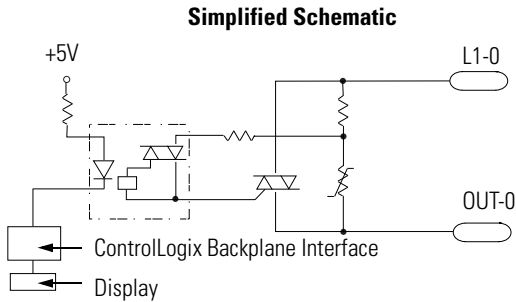

Technical Specifications - 1756-ON8

Attribute	1756-ON8
Outputs	8 (4 points/group)
Voltage category	24V AC
Operating voltage range	10...30V AC, current >50 mA, 47...63Hz 16...30V AC, current <50 mA, 47...63Hz
Output delay time	
OFF to ON	9.3 ms @ 60 Hz 11 ms @ 50 Hz
ON to OFF	9.3 ms @ 60 Hz 11 ms @ 50 Hz
Current draw @ 5.1V	200 mA
Current draw @ 24V	2 mA
Total backplane power	1.07 W
Power dissipation, max	5.1 W @ 60 °C (140 °F)
Thermal dissipation	17.39 BTU/hr
Off-state leakage current, max	3 mA per point
On-state voltage drop, max	1.5V peak @ 2 A 6V peak @ load current < 50 mA
Current per point, max	2 A @ 60 °C (140 °F)

Technical Specifications - 1756-ON8

Attribute	1756-ON8
Current per module, max	5 A @ 30 °C (86 °F) linear derating 4 A @ 60 °C (140 °F) linear derating
Surge current per point	20 A for 43 ms per point, repeatable every 2 s @ 60 °C (140 °F)
Load current, min	10 mA per point
Commutating voltage	4V/μs for loads > 50 mA 0.2V/μs for loads < 50 mA ⁽¹⁾
Scheduled outputs	Synchronization within 16.7 s max, reference to the Coordinated System Time
Fault states per point	Hold last state, on or off (off is default)
States in Program mode per point	Hold last state, on or off (off is default)
Isolation voltage	250V (continuous), basic insulation type, outputs-to-backplane, and output group-to-group No isolation between individual group outputs Routine tested @ 1350V AC for 2 s
Module keying	Electronic, software configurable
Fusing	Not protected. A fused IFM is recommended to protect outputs
Removable terminal block	1756-TBNH 1756-TBSH
RTB keying	User-defined mechanical
Slot width	1
Wire category	1 ⁽²⁾
North American temperature code	T4A
IEC temperature code	T4
Enclosure type	None (open style)

(1) The commutating dv/dt of the output voltage (OUTPUT to L2) should not exceed 0.2V/ms for loads under 50 mA. The commutating dv/dt rating of the module for loads 50...500 mA (OUTPUT to L2) is 4V/ms maximum. If the commutating dv/dt rating of the TRIAC is exceeded, the TRIAC could latch on. If the commutating dv/dt rating is exceeded in the 10...50 mA range, a resistor may be added AC cross the output and L2. The purpose of this resistor is to increase the total output current to 50 mA ($I=V/R$). At 50 mA and above, the module has a higher commutating dv/dt rating. When adding a resistor for the output to L2, be sure it is rated for the power that it will dissipate ($P=(V^2)/R$). If the commutating dv/dt rating is exceeded in the 50...500 mA range, the L1 AC waveform could be at fault. Be sure the waveform is a good sinusoid, void of any anomalies such as distorted or flattened sections.

(2) Use this conductor category information for planning conductor routing as described in the system-level installation manual. See the Industrial Automation Wiring and Grounding Guidelines, publication [1770-4.1](#).

Environmental Specifications - 1756-ON8

Attribute	1756-ON8
Temperature, operating IEC 60068-2-1 (Test Ad, Operating Cold), IEC 60068-2-2 (Test Bd, Operating Dry Heat), IEC 60068-2-14 (Test Nb, Operating Thermal Shock)	0...60 °C (32...140 °F)
Temperature, surrounding air, max	60 °C (140 °F)
Temperature, storage IEC 60068-2-1 (Test Ab, Unpackaged Nonoperating Cold), IEC 60068-2-2 (Test Bb, Unpackaged Nonoperating Dry Heat), IEC 60068-2-14 (Test Na, Unpackaged Nonoperating Thermal Shock)	-40...85 °C (-40...185 °F)

Environmental Specifications - 1756-ON8

Attribute	1756-ON8
Relative humidity IEC 60068-2-30 (Test Db, Unpackaged Nonoperating Damp Heat)	5...95% noncondensing
Vibration IEC 60068-2-6 (Test Fc, Operating)	2 g @ 10...500 Hz
Shock, operating IEC 60068-2-27 (Test Ea, Unpackaged Shock)	30 g
Shock, nonoperating IEC 60068-2-27 (Test Ea, Unpackaged Shock)	50 g
Emissions	CISPR 11: Group 1, Class A
ESD immunity IEC 61000-4-2	6 kV contact discharges 8 kV air discharges
Radiated RF immunity IEC 61000-4-3	10V/m with 1 kHz sine-wave 80% AM from 80... 2000 MHz 10V/m with 200 Hz 50% Pulse 100% AM @ 900 MHz 10V/m with 200 Hz 50% Pulse 100% AM @ 1890 MHz 3V/m with 1 kHz sine-wave 80% AM from 2000...2700 MHz
EFT/B immunity IEC 61000-4-4	±4 kV at 5 kHz on signal ports
Surge transient immunity IEC 61000-4-5	±1 kV line-line (DM) and ±2 kV line-earth (CM) on signal ports
Conducted RF immunity IEC 61000-4-6	10V rms with 1 kHz sine-wave 80% AM from 150 kHz...80 MHz

Certifications - 1756-ON8

Certification ⁽¹⁾	1756-ON8
UL	UL Listed Industrial Control Equipment, certified for US and Canada. See UL File E65584.
CSA	CSA Certified Process Control Equipment. See CSA File LR54689C. CSA Certified Process Control Equipment for Class I, Division 2 Group A,B,C,D Hazardous Locations. See CSA File LR69960C.
CE	European Union 2004/108/IEC EMC Directive, compliant with: <ul style="list-style-type: none"> • EN 61326-1; Meas./Control/Lab., Industrial Requirements • EN 61000-6-2; Industrial Immunity • EN 61000-6-4; Industrial Emissions • EN 61131-2; Programmable Controllers (Clause 8, Zone A & B) European Union 2006/95/EC LVD, compliant with: <ul style="list-style-type: none"> • EN 61131-2; Programmable Controllers (Clause 11)
C-Tick	Australian Radiocommunications Act, compliant with: AS/NZS CISPR 11; Industrial Emissions
Ex	European Union 94/9/EC ATEX Directive, compliant with: <ul style="list-style-type: none"> • EN 60079-15; Potentially Explosive Atmospheres, Protection "n" • EN 60079-0; General Requirements II 3 G Ex nA IIC T4 X
FM	FM Approved Equipment for use in Class I Division 2 Group A,B,C,D Hazardous Locations

(1) When marked. See the Product Certification link at <http://www.ab.com> for Declarations of Conformity, Certificates, and other certification details.

1756-OV16E

ControlLogix DC (10...30V) electronically-fused, sinking output module

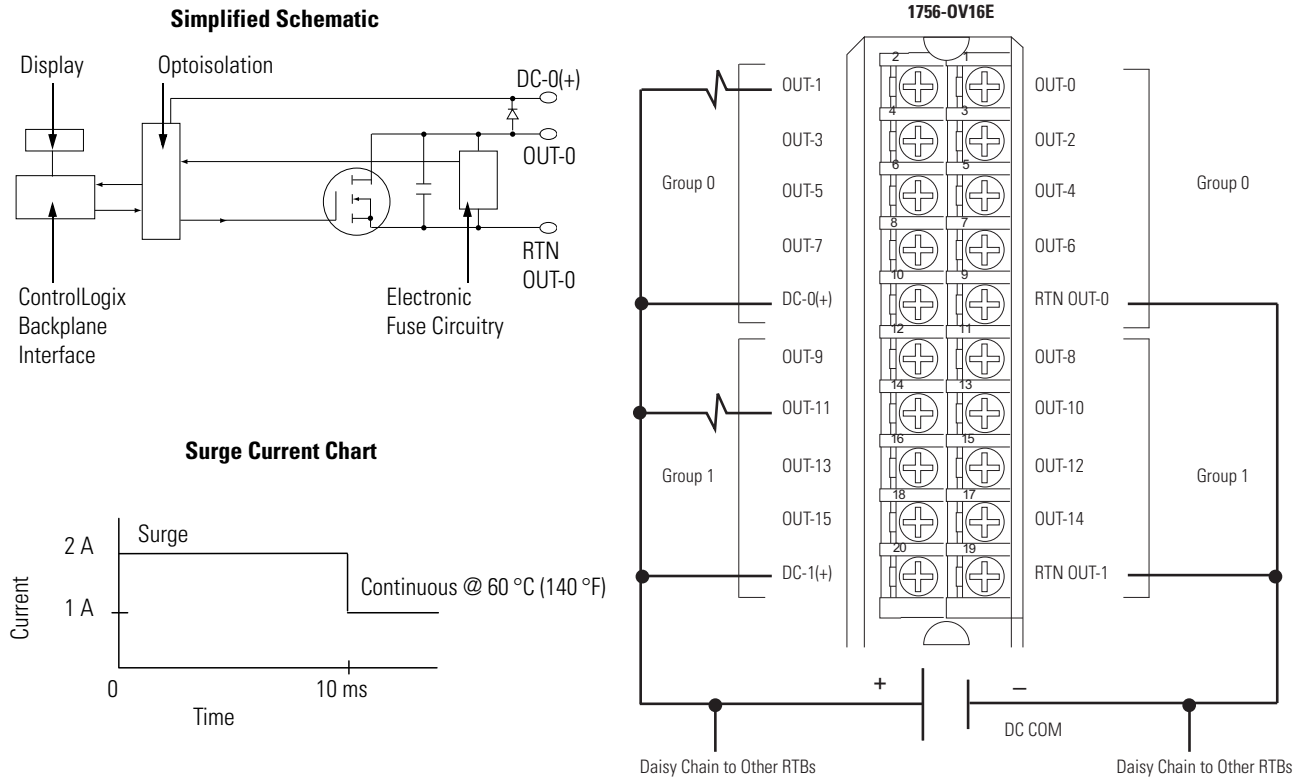

Diagnostic Specifications - 1756-OV16E

Attribute	1756-OV16E
Short trip	5 A for 20 ms @ 24V DC (output on, then short) 5 A for 20 ms @ 24V DC (output on into short)
Time stamp of diagnostics	±1 ms

Technical Specifications - 1756-OV16E

Attribute	1756-OV16E
Outputs	16 electronically fused (8 points/group)
Pilot duty	1 A (DC-13/SR)
Voltage category	12/24V DC sink
Output delay time OFF to ON ON to OFF	75 µs nom/1 ms max 360 µs nom/1 ms max
Operating voltage range	10...30V DC
Current draw @ 5.1V	210 mA
Current draw @ 24V	2 mA
Total backplane power	1.12 W

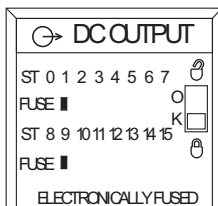

Technical Specifications - 1756-OV16E

Attribute	1756-OV16E
Power dissipation, max	6.72 W @ 60 °C (140 °F)
Thermal dissipation	22.94 BTU/hr
Off-state leakage current per point, max	1 mA per point
On-state voltage drop, max	700 mV DC @ 1 A
Current per point, max	1 A @ 60 °C (140 °F)
Current per module, max	8 A @ 60 °C (140 °F)
Surge current per point	2 A for 10 ms per Point, repeatable every 2 s @ 60 °C (140 °F)
Load current, min	2 mA per point
Scheduled outputs	Synchronization within 16.7 s max, reference to the Coordinated System Time
Fault states per point	Hold last state, on or off (off is default)
States in Program mode per point	Hold last state, on or off (off is default)
Isolation voltage	250V (continuous), basic insulation type, outputs-to-backplane, and output group-to-group No isolation between individual group outputs Routine tested @ 1350V AC for 2 s
Module keying	Electronic, software configurable
Fusing	Electronically fused per group
Removable terminal block	1756-TBNH 1756-TBSH
RTB keying	User-defined mechanical
Slot width	1
Wire category	1 ⁽¹⁾
North American temperature code	T4
IEC temperature code	T4
Enclosure type	None (open-style)

(1) Use this conductor category information for planning conductor routing as described in the system-level installation manual. See the Industrial Automation Wiring and Grounding Guidelines, publication [1770-4.1](#).

Environmental Specifications - 1756-OV16E

Attribute	1756-OV16E
Temperature, operating IEC 60068-2-1 (Test Ad, Operating Cold), IEC 60068-2-2 (Test Bd, Operating Dry Heat), IEC 60068-2-14 (Test Nb, Operating Thermal Shock)	0...60 °C (32...140 °F)
Temperature, surrounding air, max	60 °C (140 °F)
Temperature, storage IEC 60068-2-1 (Test Ab, Unpackaged Nonoperating Cold), IEC 60068-2-2 (Test Bb, Unpackaged Nonoperating Dry Heat), IEC 60068-2-14 (Test Na, Unpackaged Nonoperating Thermal Shock)	-40...85 °C (-40...185 °F)
Relative humidity IEC 60068-2-30 (Test Db, Unpackaged Nonoperating Damp Heat)	5...95% noncondensing
Vibration IEC 60068-2-6 (Test Fc, Operating)	2 g @ 10...500 Hz
Shock, operating IEC 60068-2-27 (Test Ea, Unpackaged Shock)	30 g

Environmental Specifications - 1756-OV16E

Attribute	1756-OV16E
Shock, nonoperating IEC 60068-2-27 (Test Ea, Unpackaged Shock)	50 g
Emissions	CISPR 11: Group 1, Class A
ESD immunity IEC 61000-4-2	6 kV contact discharges 8 kV air discharges
Radiated RF immunity IEC 61000-4-3	10V/m with 1 kHz sine-wave 80% AM from 80... 2000 MHz 10V/m with 200 Hz 50% Pulse 100% AM @ 900 MHz 10V/m with 200 Hz 50% Pulse 100% AM @ 1890 MHz 3V/m with 1 kHz sine-wave 80% AM from 2000...2700 MHz
EFT/B immunity IEC 61000-4-4	±4 kV at 5 kHz on signal ports
Surge transient immunity IEC 61000-4-5	±1 kV line-line (DM) and ±2 kV line-earth (CM) on signal ports
Conducted RF immunity IEC 61000-4-6	10V rms with 1 kHz sine-wave 80% AM from 150 kHz...80 MHz

Certifications - 1756-OV16E

Certification ⁽¹⁾	1756-OV16E
UL	UL Listed Industrial Control Equipment, certified for US and Canada. See UL File E65584.
CSA	CSA Certified Process Control Equipment. See CSA File LR54689C. CSA Certified Process Control Equipment for Class I, Division 2 Group A,B,C,D Hazardous Locations. See CSA File LR69960C.
CE	European Union 2004/108/IEC EMC Directive, compliant with: <ul style="list-style-type: none"> • EN 61326-1; Meas./Control/Lab., Industrial Requirements • EN 61000-6-2; Industrial Immunity • EN 61000-6-4; Industrial Emissions • EN 61131-2; Programmable Controllers (Clause 8, Zone A & B) European Union 2006/95/EC LVD, compliant with: <ul style="list-style-type: none"> • EN 61131-2; Programmable Controllers (Clause 11)
C-Tick	Australian Radiocommunications Act, compliant with: AS/NZS CISPR 11; Industrial Emissions
Ex	European Union 94/9/EC ATEX Directive, compliant with: <ul style="list-style-type: none"> • EN 60079-15; Potentially Explosive Atmospheres, Protection "n" • EN 60079-0; General Requirements II 3 G Ex nA IIC T4 X
FM	FM Approved Equipment for use in Class I Division 2 Group A,B,C,D Hazardous Locations

(1) When marked. See the Product Certification link at <http://www.ab.com> for Declarations of Conformity, Certificates, and other certification details.

1756-0V32E

ControlLogix DC (10...30V) electronically-fused, sinking output module

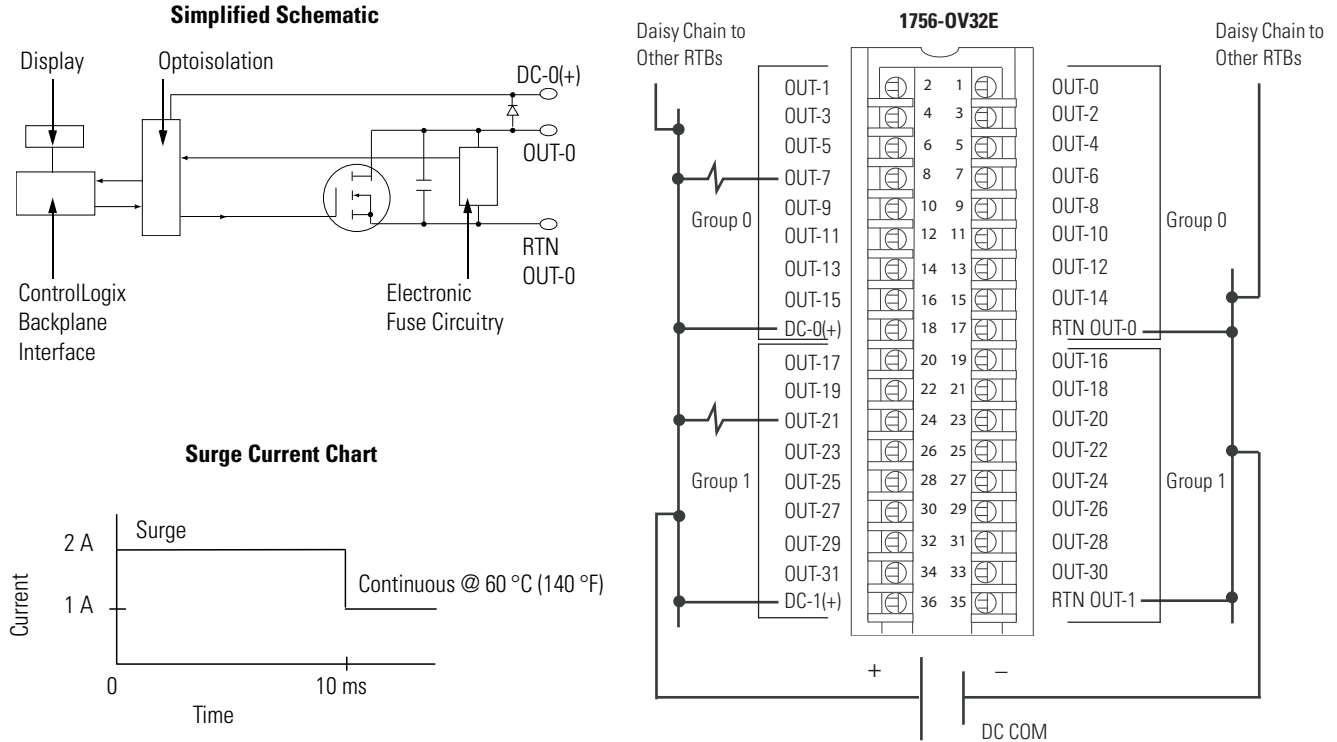

Diagnostic Specifications - 1756-0V32E

Attribute	1756-0V32E
Short trip	5 A for 20 ms @ 24V DC (output on then short) 5 A for 20 ms @ 24V DC (output into short)
Time stamp of diagnostics	±1 ms

Technical Specifications - 1756-0V32E

Attribute	1756-0V32E
Outputs	32 electronically fused (16 points/group)
Voltage category	12/24V DC sink
Operating voltage range	10...30V DC
Output delay time (24V to 0V DC transition)	
OFF to ON	75 µs nom/300 µs max
ON to OFF	230 µs nom/1 ms max
Current draw @ 5.1V	390 mA
Current draw @ 24V	2 mA
Total backplane power	2.04 W
Power dissipation, max	5.88 W @ 60 °C (140 °F)
Thermal dissipation	20.1 BTU/hr

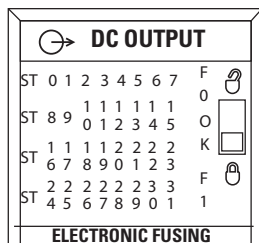

Technical Specifications - 1756-OV32E

Attribute	1756-OV32E
Off-state leakage current per point, max	1 mA per point
On-state voltage drop, max	350 mV DC @ 0.5 A
Current per point, max	0.5 A @ 50 °C (122 °F) linear derating 0.35 A @ 60 °C (140 °F)
Current per group, max	8 A @ 50 °C (122 °F) linear derating 5 A @ 60 °C (140 °F)
Current per module, max	16 A @ 50 °C (122 °F) linear derating 10 A @ 60 °C (140 °F)
Surge current per point	2 A for 10 ms per point, repeatable every 2 s @ 60 °C (140 °F)
Load current, min	2 mA per output
Scheduled outputs	Synchronization within 16.7 s max, reference to the Coordinated System Time
Fault states per point	Hold last state, on or off (off is default)
States in Program mode per point	Hold last state, on or off (off is default)
Isolation voltage	250V (continuous), basic insulation type, outputs-to-backplane, and output group-to-group No isolation between individual group outputs Routine tested @ 1350V AC for 2 s
Module keying	Electronic, software configurable
Fusing	Electronically fused per group
Removable terminal block	1756-TBCH 1756-TBS6H
RTB keying	User-defined mechanical
Slot width	1
Wire category	1 ⁽¹⁾
North American temperature code	T4
IEC temperature code	T4
Enclosure type	None (open-style)

(1) Use this conductor category information for planning conductor routing as described in the system-level installation manual. See the Industrial Automation Wiring and Grounding Guidelines, publication [1770-4.1](#).

Environmental Specifications - 1756-OV32E

Attribute	1756-OV32E
Temperature, operating IEC 60068-2-1 (Test Ad, Operating Cold), IEC 60068-2-2 (Test Bd, Operating Dry Heat), IEC 60068-2-14 (Test Nb, Operating Thermal Shock)	0...60 °C (32...140 °F)
Temperature, surrounding air, max	60 °C (140 °F)
Temperature, storage IEC 60068-2-1 (Test Ab, Unpackaged Nonoperating Cold), IEC 60068-2-2 (Test Bb, Unpackaged Nonoperating Dry Heat), IEC 60068-2-14 (Test Na, Unpackaged Nonoperating Thermal Shock)	-40...85 °C (-40...185 °F)
Relative humidity IEC 60068-2-30 (Test Db, Unpackaged Nonoperating Damp Heat)	5...95% noncondensing
Vibration IEC 60068-2-6 (Test Fc, Operating)	2 g @ 10...500 Hz

Environmental Specifications - 1756-OV32E

Attribute	1756-OV32E
Shock, operating IEC 60068-2-27 (Test Ea, Unpackaged Shock)	30 g
Shock, nonoperating IEC 60068-2-27 (Test Ea, Unpackaged Shock)	50 g
Emissions	CISPR 11: Group 1, Class A
ESD immunity IEC 61000-4-2	6 kV contact discharges 8 kV air discharges
Radiated RF immunity IEC 61000-4-3	10V/m with 1 kHz sine-wave 80% AM from 80... 2000 MHz 10V/m with 200 Hz 50% Pulse 100% AM @ 900 MHz 10V/m with 200 Hz 50% Pulse 100% AM @ 1890 MHz 3V/m with 1 kHz sine-wave 80% AM from 2000...2700 MHz
EFT/B immunity IEC 61000-4-4	±4 kV at 5 kHz on signal ports
Surge transient immunity IEC 61000-4-5	±1 kV line-line (DM) and ±2 kV line-earth (CM) on signal ports
Conducted RF immunity IEC 61000-4-6	10V rms with 1 kHz sine-wave 80% AM from 150 kHz...80 MHz

Certifications - 1756-OV32E

Certification ⁽¹⁾	1756-OV32E
UL	UL Listed Industrial Control Equipment, certified for US and Canada. See UL File E65584.
CSA	CSA Certified Process Control Equipment. See CSA File LR54689C. CSA Certified Process Control Equipment for Class I, Division 2 Group A,B,C,D Hazardous Locations. See CSA File LR69960C.
CE	European Union 2004/108/IEC EMC Directive, compliant with: <ul style="list-style-type: none"> • EN 61326-1; Meas./Control/Lab., Industrial Requirements • EN 61000-6-2; Industrial Immunity • EN 61000-6-4; Industrial Emissions • EN 61131-2; Programmable Controllers (Clause 8, Zone A & B) European Union 2006/95/EC LVD, compliant with: <ul style="list-style-type: none"> • EN 61131-2; Programmable Controllers (Clause 11)
C-Tick	Australian Radiocommunications Act, compliant with: AS/NZS CISPR 11; Industrial Emissions
Ex	European Union 94/9/EC ATEX Directive, compliant with: <ul style="list-style-type: none"> • EN 60079-15; Potentially Explosive Atmospheres, Protection "n" • EN 60079-0; General Requirements II 3 G Ex nA IIC T4 X

(1) When marked. See the Product Certification link at <http://www.ab.com> for Declarations of Conformity, Certificates, and other certification details.

1756-OW16I

ControlLogix AC (10...265V) DC (5...150V) isolated contact module

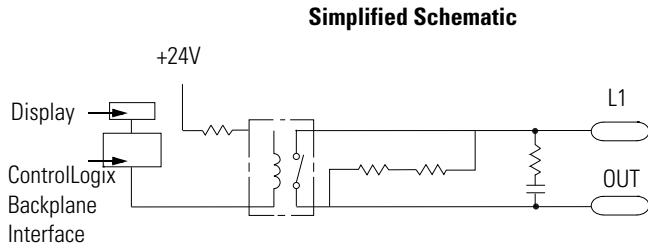

Additional jumper bars are available as cat. no. 1756-JMPR.

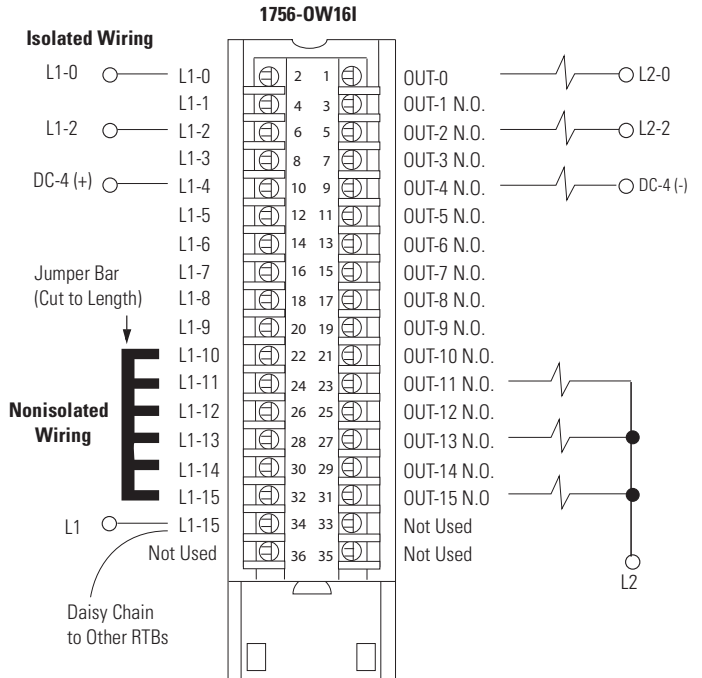

Technical Specifications - 1756-OW16I

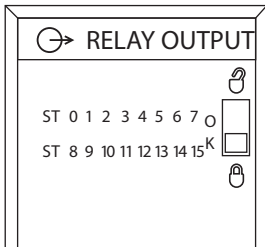

Attribute	1756-OW16I
Outputs	16 N.O. individually isolated
Pilot duty	C300/R150
Operating voltage range	5...125V DC 10...240V AC
Output voltage range (load dependent)	2 A @ 5...30V DC 0.5 A @ 48V DC 0.25 A @ 125V DC 2 A @ 125/240V AC
Output delay time OFF to ON ON to OFF	10 ms max 10 ms max
Current draw @ 5.1V	150 mA
Current draw @ 24V	150 mA
Total backplane power	4.4 W
Power dissipation, max	4.5 W @ 60 °C (140 °F)
Thermal dissipation	15.35 BTU/hr
Off-state leakage current per point, max	1.5 mA per point
Initial contact resistance, max	100 mΩ @ 6V 1 A
Switching frequency, max	1 operation/3 s (0.3 Hz at rated load)
Bounce time, mean	1.2 ms
Expected contact life	300 K cycles resistive 100 K cycles inductive

Technical Specifications - 1756-0W16I

Attribute	1756-0W16I
Scheduled outputs	Synchronization within 16.7 s max, reference to the Coordinated System Time
Configurable fault states per point	Hold last state, on or off (off is default)
Configurable states in Program mode per point	Hold last state, on or off (off is default)
Isolation voltage	250V (continuous), basic insulation type, outputs-to-backplane, and output-to-output Routine tested @ 1350V AC for 2 s
Module keying	Electronic, software configurable
Fusing	Not protected. A fused IFM can be used to protect outputs. See publication 1492-TD008 . However, the ControlLogix system has been agency certified using only the ControlLogix RTBs, that is, 1756-TBCH, 1756-TBNH, 1756-TBSH, and 1756-TBS6H. Any application that requires agency certification of the ControlLogix system using other wiring termination methods may require application-specific approval by the certifying agency.
Removable terminal block	1756-TBCH 1756-TBS6H
RTB keying	User-defined mechanical
Slot width	1
Wire category	1 ⁽¹⁾
North American temperature code	T4A
Enclosure type	None (open-style)

(1) Use this conductor category information for planning conductor routing as described in the system-level installation manual. See the Industrial Automation Wiring and Grounding Guidelines, publication [1770-4.1](#).

Environmental Specifications - 1756-OW16I

Attribute	1756-OW16I
Temperature, operating IEC 60068-2-1 (Test Ad, Operating Cold), IEC 60068-2-2 (Test Bd, Operating Dry Heat), IEC 60068-2-14 (Test Nb, Operating Thermal Shock)	0...60 °C (32...140 °F)
Temperature, surrounding air, max	60 °C (140 °F)
Temperature, storage IEC 60068-2-1 (Test Ab, Unpackaged Nonoperating Cold), IEC 60068-2-2 (Test Bb, Unpackaged Nonoperating Dry Heat), IEC 60068-2-14 (Test Na, Unpackaged Nonoperating Thermal Shock)	-40...85 °C (-40...185 °F)
Relative humidity IEC 60068-2-30 (Test Db, Unpackaged Nonoperating Damp Heat)	5...95% noncondensing
Vibration IEC 60068-2-6 (Test Fc, Operating)	2 g @ 10...500 Hz
Shock, operating IEC 60068-2-27 (Test Ea, Unpackaged Shock)	30 g
Shock, nonoperating IEC 60068-2-27 (Test Ea, Unpackaged Shock)	50 g
Emissions	CISPR 11: Group 1, Class A
ESD immunity IEC 61000-4-2	6 kV contact discharges 8 kV air discharges
Radiated RF immunity IEC 61000-4-3	10V/m with 1 kHz sine-wave 80% AM from 80...2000 MHz 10V/m with 200 Hz 50% Pulse 100% AM @ 900 MHz 10V/m with 200 Hz 50% Pulse 100% AM @ 1890 MHz 3V/m with 1 kHz sine-wave 80% AM from 2000...2700 MHz
EFT/B immunity IEC 61000-4-4	±4 kV at 5 kHz on signal ports
Surge transient immunity IEC 61000-4-5	±1 kV line-line (DM) and ±2 kV line-earth (CM) on signal ports
Conducted RF immunity IEC 61000-4-6	10V rms with 1 kHz sine-wave 80% AM from 150 kHz...80 MHz
Oscillatory surge withstand IEEE C37.90.1	3 kV

Certifications - 1756-OW16I

Certification ⁽¹⁾	1756-OW16I
UL	UL Listed Industrial Control Equipment, certified for US and Canada. See UL File E65584.
CSA	CSA Certified Process Control Equipment. See CSA File LR54689C. CSA Certified Process Control Equipment for Class I, Division 2 Group A,B,C,D Hazardous Locations. See CSA File LR69960C.
CE	European Union 2004/108/IEC EMC Directive, compliant with: <ul style="list-style-type: none"> • EN 61326-1; Meas./Control/Lab., Industrial Requirements • EN 61000-6-2; Industrial Immunity • EN 61000-6-4; Industrial Emissions • EN 61131-2; Programmable Controllers (Clause 8, Zone A & B) European Union 2006/95/EC LVD, compliant with: <ul style="list-style-type: none"> • EN 61131-2; Programmable Controllers
C-Tick	Australian Radiocommunications Act, compliant with: AS/NZS CISPR 11; Industrial Emissions
FM	FM Approved Equipment for use in Class I Division 2 Group A,B,C,D Hazardous Locations
TÜV	TÜV Certified for Functional Safety ⁽²⁾ : Capable of SIL 2

(1) When marked. See the Product Certification link at <http://www.ab.com> for Declarations of Conformity, Certificates, and other certification details.(2) When used with specified firmware revisions and in accordance with application guidelines described in Using ControlLogix in SIL2 Applications Safety Reference Manual, publication [1756-RM001](#).

1756-OX8I

ControlLogix AC (10...265V) DC (5...150V) isolated contact module

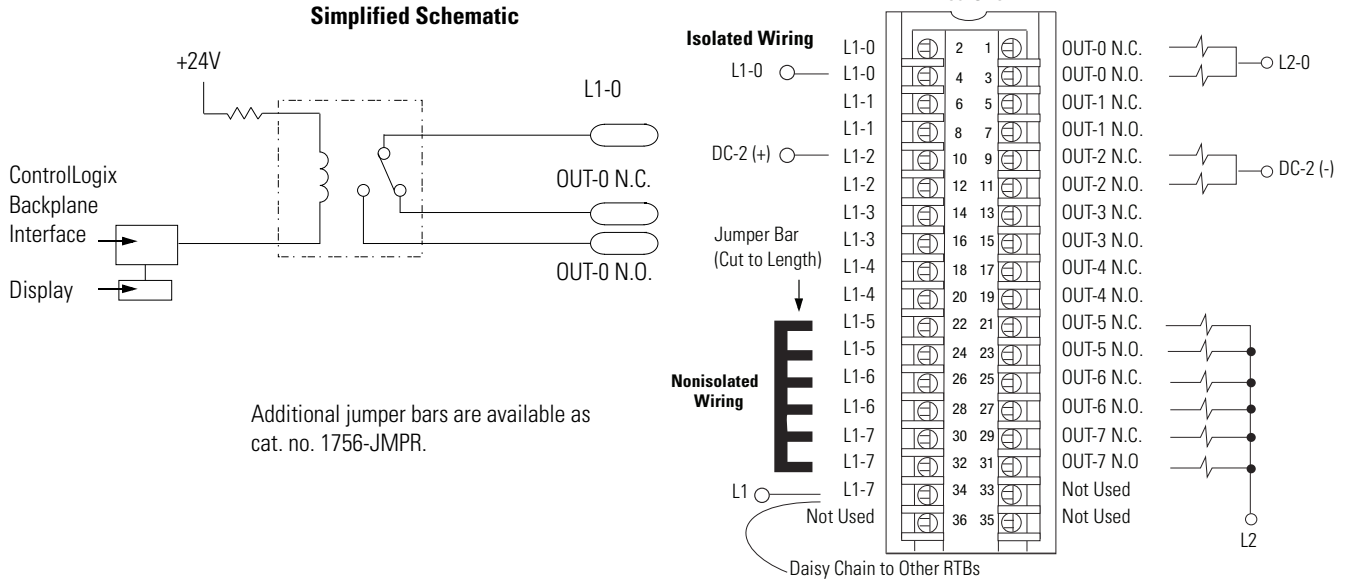

Technical Specifications - 1756-OX8I

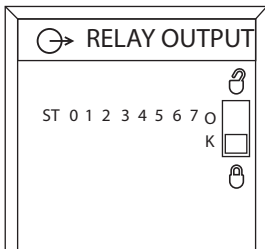

Attribute	1756-OX8I
Outputs	8 N.O. 8 N.C. individually isolated (2 points/group)
Pilot duty	C300/R150
Operating voltage range	5...125V DC 10...240V AC
Contact current rating	2 A @ 5...30V DC 0.5 A @ 48V DC 0.25 A @ 125V DC 2 A @ 125/240V AC
Output delay time OFF to ON ON to OFF	13 ms max 13 ms max
Current draw @ 5.1V	100 mA
Current draw @ 24V	100 mA
Total backplane power	2.9 W
Power dissipation, max	3.1 W @ 60 °C (140 °F)
Thermal dissipation	10.57 BTU/hr
Off-state leakage current per point, max	0 mA
Initial contact resistance, max	100 mΩ @ 6V 1 A
Switching frequency, max	1 operation/3 s (0.3 Hz at rated load)
Bounce time, mean	1.2 ms
Expected contact life	300 K cycles resistive 100 K cycles inductive
Scheduled outputs	Synchronization within 16.7 s max, reference to the Coordinated System Time
Configurable fault states per point	Hold last state, on or off (off is default)

Technical Specifications - 1756-OX8I

Attribute	1756-OX8I
Configurable states in Program mode per point	Hold last state, on or off (off is default)
Isolation voltage	250V (continuous), basic insulation type, outputs-to-backplane, and output-to-output Routine tested @ 1350V AC for 2 s
Module keying	Electronic, software configurable
Fusing	Not protected. A fused IFM is recommended to protect outputs
Removable terminal block	1756-TBCH 1756-TBS6H
RTB keying	User-defined mechanical
Slot width	1
Wire category	1 ⁽¹⁾
North American temperature code	T4A
Enclosure type	None (open-style)

(1) Use this conductor category information for planning conductor routing as described in the system-level installation manual. See the Industrial Automation Wiring and Grounding Guidelines, publication [1770-4.1](#).

Environmental Specifications - 1756-OX8I

Attribute	1756-OX8I
Temperature, operating IEC 60068-2-1 (Test Ad, Operating Cold), IEC 60068-2-2 (Test Bd, Operating Dry Heat), IEC 60068-2-14 (Test Nb, Operating Thermal Shock)	0...60 °C (32...140 °F)
Temperature, surrounding air, max	60 °C (140 °F)
Temperature, storage IEC 60068-2-1 (Test Ab, Unpackaged Nonoperating Cold), IEC 60068-2-2 (Test Bb, Unpackaged Nonoperating Dry Heat), IEC 60068-2-14 (Test Na, Unpackaged Nonoperating Thermal Shock)	-40...85 °C (-40...185 °F)
Relative humidity IEC 60068-2-30 (Test Db, Unpackaged Nonoperating Damp Heat)	5...95% noncondensing
Vibration IEC 60068-2-6 (Test Fc, Operating)	2 g @ 10...500 Hz
Shock, operating IEC 60068-2-27 (Test Ea, Unpackaged Shock)	30 g
Shock, nonoperating IEC 60068-2-27 (Test Ea, Unpackaged Shock)	50 g
Emissions	CISPR 11: Group 1, Class A
ESD immunity IEC 61000-4-2	6 kV contact discharges 8 kV air discharges
Radiated RF immunity IEC 61000-4-3	10V/m with 1 kHz sine-wave 80% AM from 80...2000 MHz 10V/m with 200 Hz 50% Pulse 100% AM @ 900 MHz 10V/m with 200 Hz 50% Pulse 100% AM @ 1890 MHz 3V/m with 1 kHz sine-wave 80% AM from 2000...2700 MHz
EFT/B immunity IEC 61000-4-4	±4 kV at 5 kHz on signal ports
Surge transient immunity IEC 61000-4-5	±1 kV line-line (DM) and ±2 kV line-earth (CM) on signal ports
Conducted RF immunity IEC 61000-4-6	10V rms with 1 kHz sine-wave 80% AM from 150 kHz...80 MHz
Oscillatory surge withstand IEEE C37.90.1	3 kV

Certifications - 1756-0X8I

Certification ⁽¹⁾	1756-0X8I
UL	UL Listed Industrial Control Equipment, certified for US and Canada. See UL File E65584.
CSA	CSA Certified Process Control Equipment. See CSA File LR54689C. CSA Certified Process Control Equipment for Class I, Division 2 Group A,B,C,D Hazardous Locations. See CSA File LR69960C.
CE	European Union 2004/108/IEC EMC Directive, compliant with: <ul style="list-style-type: none"> • EN 61326-1; Meas./Control/Lab., Industrial Requirements • EN 61000-6-2; Industrial Immunity • EN 61000-6-4; Industrial Emissions • EN 61131-2; Programmable Controllers (Clause 8, Zone A & B) European Union 2006/95/EC LVD, compliant with: <ul style="list-style-type: none"> • EN 61131-2; Programmable Controllers
C-Tick	Australian Radiocommunications Act, compliant with: AS/NZS CISPR 11; Industrial Emissions
FM	FM Approved Equipment for use in Class I Division 2 Group A,B,C,D Hazardous Locations
TÜV	TÜV Certified for Functional Safety ⁽²⁾ : Capable of SIL 2

(1) When marked. See the Product Certification link at <http://www.ab.com> for Declarations of Conformity, Certificates, and other certification details.

(2) When used with specified firmware revisions and in accordance with application guidelines described in Using ControlLogix in SIL2 Applications Safety Reference Manual, publication [1756-RM001](#).

1756-CFM

ControlLogix configurable flow meter module

1756-CFM Standard Magnetic Pickup

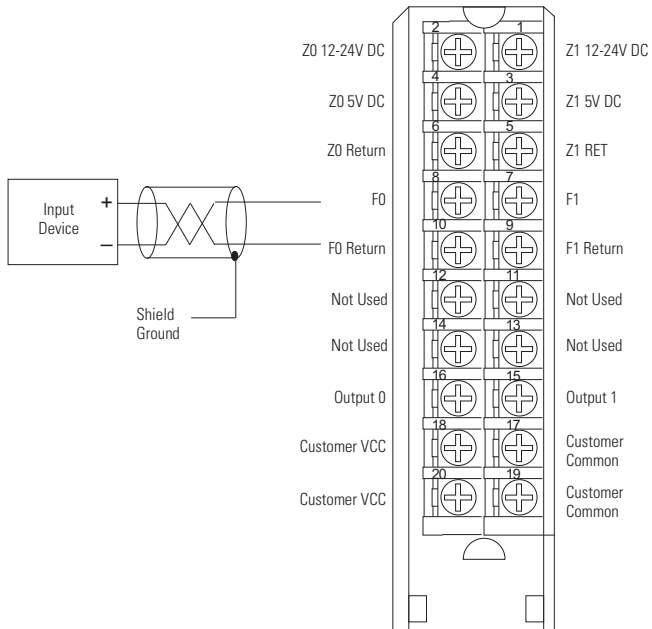

1756-CFM Standard Output

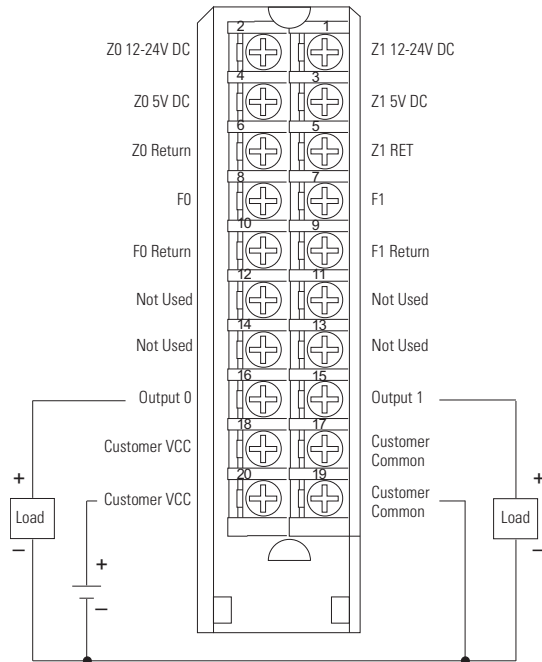

- This wiring diagram can be used in applications with 50 mV (magnetic pickup), 1.3V (TTL), or 4V (preamp level) thresholds. You must use RSLogix 5000 software to choose the appropriate threshold level for your specific application.

The 1756-CFM module provides Totalizer mode for metering applications, or high-speed frequency measurements for speed or rate control applications, on two channels connected to flowmeters.

1756-CFM Standard Prover/Store Count

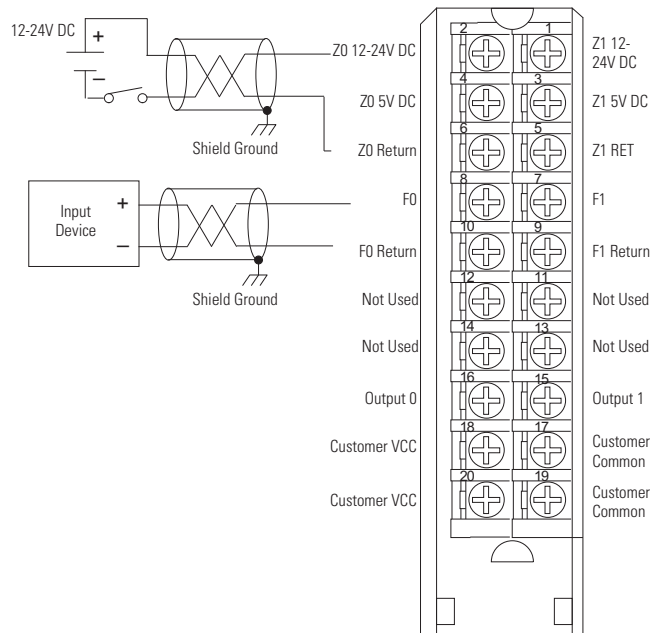

- Detectors 1 and 2 must be wired in parallel.
- Customer VCC may be used to power detectors. In this case, though, the maximum current on the wiring arm must be less than 4 A.
- The wiring example above shows a 12-24V DC standard prover connected to the module. If you use a 5V DC standard prover, make sure the positive wire is connected to the 5V terminal (such as Z0 5V DC).

Technical Specifications - 1756-CFM

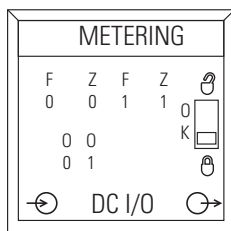

Attribute	1756-CFM
Inputs	4 (2 per channel)
Inputs per channel	2 flowmeter (F) inputs used for all modes 2 gate inputs used in Totalizer mode for prover/store count
Outputs	2 current sourcing
Current draw at 5.1V	300 mA
Current draw at 24V	16 mA
Total backplane power	1.7 W
Power dissipation, max	6 W @ 60 °C (140 °F)
Thermal dissipation	20.4 BTU/hr
Isolation voltage	250V (continuous), reinforced insulation type, I/O-to-backplane 250V (continuous), basic insulation type, I/O group-to-group Routine tested at 1900V DC for 2 s
Module keying	Electronic, software configurable
Removable terminal block	1756-TBNH 1756-TBSH

Technical Specifications - 1756-CFM

Attribute	1756-CFM
RTB keying	User-defined mechanical
Slot width	1
Wire category	2 on signal ports 1 on power ports ⁽¹⁾
North American temperature code	T4
Enclosure type	None (open-style)
Totalizer fill and prover	Yes
High resolution, max	100 kHz
Frequency	0.0005 Hz resolution
Reverse polarity protection	Outputs only

(1) Use this conductor category information for planning conductor routing as described in the system-level installation manual. See the Industrial Automation Wiring and Grounding Guidelines, publication [1770-4.1](#).

Input Specifications - 1756-CFM

Attributes	1756-CFM
Inputs	4 (2 per channel)
Inputs per channel	2 flowmeter (F) inputs used for all modes 2 gate inputs used in Totalizer mode for prover/store count
Count range, max	2,147,483,647
Input frequency, max	100 kHz @ flowmeter inputs (overrange occurs at 100 kHz)
Flowmeter input voltage	±30V, selectable input thresholds of 50 mV, 1.3V and 4V: <ul style="list-style-type: none"> • ±30V peak unterminated open circuit voltage, magnetic pickup • TTL compatible, input voltage >1.3V DC is Logic 1 and -0.7...1.3V DC is Logic 0 • 12...24V DC powered preamp output, 4V DC threshold
Flowmeter input impedance	5 kΩ ±30% resistive
Filtering (inputs F0 & F1)	Firmware selectable: High-speed 100 kHz or low-pass filter for frequencies < 70 Hz
Gate input voltage range	5V operation: 4.5...5.5V DC 12/24V operation: 10...31.2V DC
Gate input on-state current, min	4 mA
Gate input on-state current, nom	15 mA
Mechanical filter debouncing (Z0 & Z1 Inputs)	Software selectable
Input sampling period	User selectable

Output Specifications - 1756-CFM

Attribute	1756-CFM
Outputs	2 current sourcing
Output voltage source	Customer supplied
Output voltage range, nom	5V operation: 4.5...5.5V DC for 3...20 mA load per point 12/24V operation: 10...31.2V DC for 40 mA...1 A load per point
Output type	IEC 1A 24V DC
Output Current per point	1 A @ 10...31.2V DC 20 mA @ 4.5...5.5V DC ⁽¹⁾
Surge current	2 A for 50 ms, repeatable every 2 s
Off-state leakage current, max	< 300 μ A @ 31.2V DC
On-state voltage drop, max	0.6 Ω x current
Output control	Any number of outputs is assignable to any of 2 flowmeter channels Each output can have 2 "turn-on" and "turn-off" preset values
Output switching time	< 50 μ s turn on, <300 μ s turn off Outputs triggered by Total; all other "turn-on" and "turn-off" times <1ms
Overload current	Electronic (< 4A)
Output short circuit protection	Electronic (No indication of fault. Remove overload and toggle output on/off to restore.)
Output reverse polarity protection	Yes (If wired incorrectly, module outputs may be permanently disabled.)

(1) All outputs can be on simultaneously without derating.

Environmental Specifications - 1756-CFM

Attribute	1756-CFM
Temperature, operating IEC 60068-2-1 (Test Ad, Operating Cold), IEC 60068-2-2 (Test Bd, Operating Dry Heat), IEC 60068-2-14 (Test Nb, Operating Thermal Shock)	0...60 °C (32...140 °F)
Temperature, surrounding air, max	60 °C (140 °F)
Temperature, storage IEC 60068-2-1 (Test Ab, Unpackaged Nonoperating Cold), IEC 60068-2-2 (Test Bb, Unpackaged Nonoperating Dry Heat), IEC 60068-2-14 (Test Na, Unpackaged Nonoperating Thermal Shock)	-40...85 °C (-40...185 °F)
Relative humidity IEC 60068-2-30 (Test Db, Unpackaged Nonoperating Damp Heat)	5...95% noncondensing
Vibration IEC 60068-2-6 (Test Fc, Operating)	2 g @ 10...500 Hz
Shock, operating IEC 60068-2-27 (Test Ea, Unpackaged Shock)	30 g
Shock, nonoperating IEC 60068-2-27 (Test Ea, Unpackaged Shock)	50 g
Emissions	CISPR 11: Group 1, Class A
ESD immunity IEC 61000-4-2	6 kV contact discharges 8 kV air discharges
Radiated RF immunity IEC 61000-4-3	10V/m with 1k Hz sine-wave 80% AM from 80... 2000 MHz 10V/m with 200 Hz 50% Pulse 100% AM @ 900 MHz 10V/m with 200 Hz 50% Pulse 100% AM @ 1890 MHz 3V/m with 1 kHz sine-wave 80% AM from 2000...2700 MHz

Environmental Specifications - 1756-CFM

Attribute	1756-CFM
EFT/B immunity IEC 61000-4-4	±4 kV at 5 kHz on unshielded output and power ports ±4 kV at 5 kHz on shielded input ports
Surge transient immunity IEC 61000-4-5	±1 kV line-line (DM) and ±2 kV line-earth (CM) on unshielded output and power ports ±2 kV line-earth (CM) on shielded input ports
Conducted RF immunity IEC 61000-4-6	10V rms with 1 kHz sine-wave 80% AM from 150 kHz...80 MHz on shielded signal ports

Certifications - 1756-CFM

Certification ⁽¹⁾	1756-CFM
UL	UL Listed Industrial Control Equipment, certified for US and Canada. See UL File E65584.
CSA	CSA Certified Process Control Equipment. See CSA File LR54689C. CSA Certified Process Control Equipment for Class I, Division 2 Group A,B,C,D Hazardous Locations. See CSA File LR69960C.
CE	European Union 2004/108/IEC EMC Directive, compliant with: <ul style="list-style-type: none"> • EN 61326-1; Meas./Control/Lab., Industrial Requirements • EN 61000-6-2; Industrial Immunity • EN 61000-6-4; Industrial Emissions • EN 61131-2; Programmable Controllers (Clause 8, Zone A & B) European Union 2006/95/EC LVD, compliant with: <ul style="list-style-type: none"> • EN 61131-2; Programmable Controllers (Clause 11)
C-Tick	Australian Radiocommunications Act, compliant with: AS/NZS CISPR 11; Industrial Emissions

(1) When marked. See the Product Certification link at <http://www.ab.com> for Declarations of Conformity, Certificates, and other certification details.

1756-HSC

ControlLogix high-speed counter module

1756-HSC to Allen-Bradley 845 Incremental Encoder

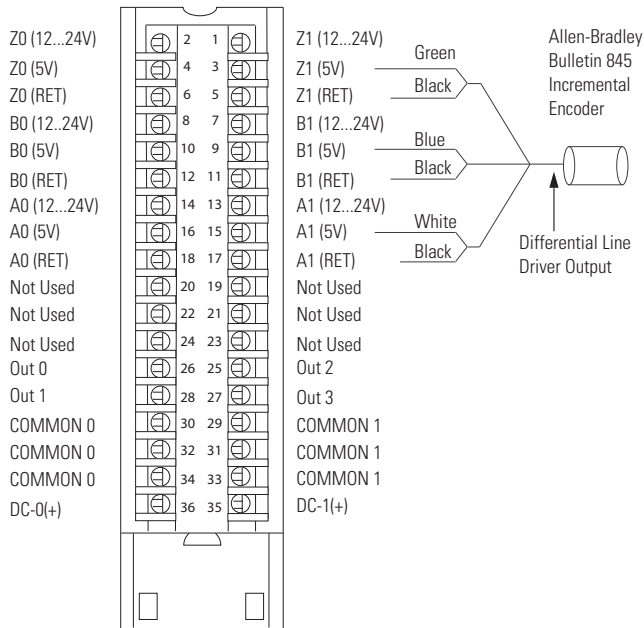

1756-HSC to Allen-Bradley Series 10,000 Photoelectric Sensor

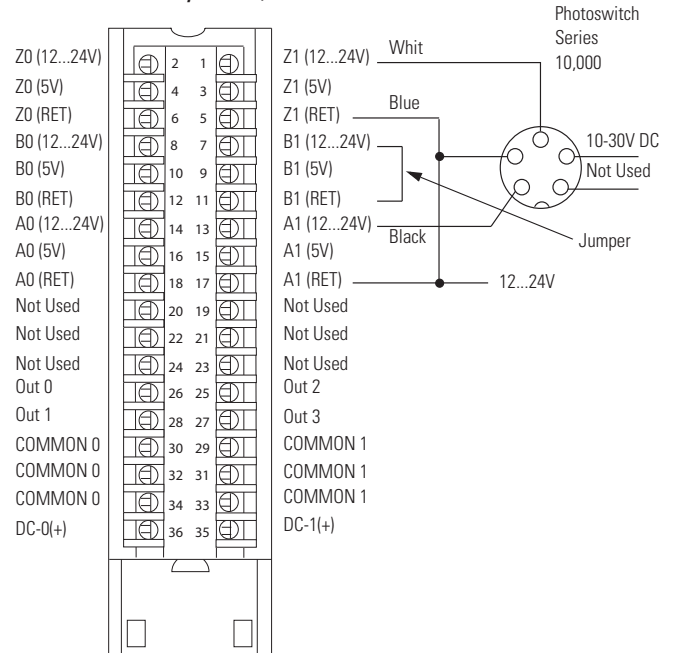

The 1756-HSC module provides four high-speed, output-switching, on-off windows. The module uses pulses for counting and frequency.

1756-HSC to Allen-Bradley 8723-wire DC Proximity Sensor

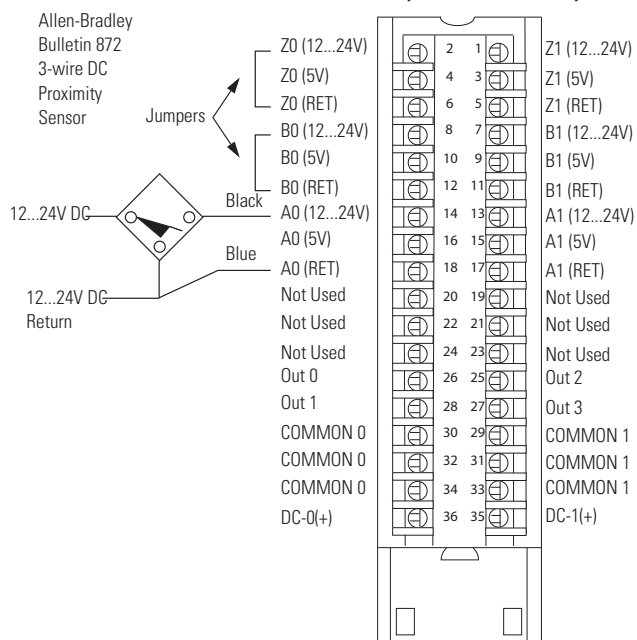

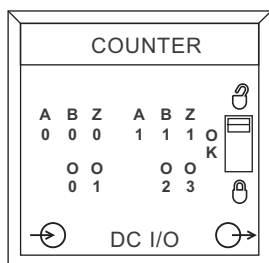

Technical Specifications - 1756-HSC

Attribute	1756-HSC
Number of counters	2
Inputs per counter	3 (A, B, Z for gate/reset)
Outputs	4 (2 points/group)
Operating voltage range	5V operation: 4.5...5.5V DC 12/24V operation: 10...26.4V DC
Current draw at 5.1V	300 mA
Current draw at 24V	3 mA
Total backplane power	1.6 W
Power dissipation, max	5.6 W @ 60 °C (140 °F)
Thermal dissipation	19.1 BTU/hr
Isolation voltage	125V (continuous), basic insulation type, input group-to-backplane 30V (continuous), basic insulation type, input group-to-input group Routine tested at 1900V DC for 2 s
Module keying	Electronic, software configurable
Removable terminal block	1756-TBCH 1756-TBS6H
RTB keying	User-defined mechanical
Slot width	1
Wire category	2 on signal ports 1 on power ports ⁽¹⁾
North American temperature code	T4
IEC temperature code	T4
Enclosure type	None (open-style)

(1) Use this conductor category information for planning conductor routing as described in the system-level installation manual. See the Industrial Automation Wiring and Grounding Guidelines, publication [1770-4.1](#).

Input Specifications - 1756-HSC

Attribute	1756-HSC
Number of counters	2
Inputs per counter	3 (A, B, Z for gate/reset)
Input frequency, max	1 MHz in counter modes (A input) 500 kHz in rate measurement mode (A input) 250 kHz in encoder mode (A/B inputs, X1 or X4) 70 Hz with filter enabled
Count range	0...16, 777, 214
Counting frequency, max	1000 kHz
Input current, min	4 mA
Input current, nom	15 mA

Output Specifications - 1756-HSC

Attribute	1756-HSC
Outputs	4 (2 per common)
Output delay time OFF to ON ON to OFF	20 μ s nom/50 μ s max 60 μ s nom/300 μ s max
Off-state leakage current per point, max	300 μ A
On-state voltage drop, max	0.55V
Output current rating, per point	20 mA @ 4.5...5.5V DC 1.0 A @ 10...31.2V DC
Current limit	< 4 A
Surge current per point	2 A for 10 ms every 1s @ 60 °C (140 °F)
Load current per point, min	5V operation: 3 mA 12/24V operation: 40 mA
Output control	Up to two outputs are assigned to each counter channel Each output can have two 'turn-on' and 'turn-off' preset values
Short circuit protection	Electronic (Remove overload and toggle On/Off to restore.)
Reverse polarity protection	Yes (If wired incorrectly, module outputs may be permanently disabled.)
Counter, max	1 MHz
Rate measurement, max	500 kHz
Encoder, max	250 kHz
Debounce filter, max	70 Hz

Environmental Specifications - 1756-HSC

Attribute	1756-HSC
Temperature, operating IEC 60068-2-1 (Test Ad, Operating Cold), IEC 60068-2-2 (Test Bd, Operating Dry Heat), IEC 60068-2-14 (Test Nb, Operating Thermal Shock)	0...60 °C (32...140 °F)
Temperature, surrounding air, max	60 °C (140 °F)
Temperature, storage IEC 60068-2-1 (Test Ab, Unpackaged Nonoperating Cold), IEC 60068-2-2 (Test Bb, Unpackaged Nonoperating Dry Heat), IEC 60068-2-14 (Test Na, Unpackaged Nonoperating Thermal Shock)	-40...85 °C (-40...185 °F)
Relative humidity IEC 60068-2-30 (Test Db, Unpackaged Nonoperating Damp Heat)	5...95% noncondensing
Vibration IEC 60068-2-6 (Test Fc, Operating)	2 g @ 10...500 Hz
Shock, operating IEC 60068-2-27 (Test Ea, Unpackaged Shock)	30 g
Shock, nonoperating IEC 60068-2-27 (Test Ea, Unpackaged Shock)	50 g
Emissions	CISPR 11: Group 1, Class A
ESD immunity IEC 61000-4-2	6 kV contact discharges 8 kV air discharges
Radiated RF immunity IEC 61000-4-3	10V/m with 1 kHz sine-wave 80% AM from 80...2000 MHz 10V/m with 200 Hz 50% Pulse 100% AM @ 900 MHz 10V/m with 200 Hz 50% Pulse 100% AM @ 1890 MHz 3V/m with 1 kHz sine-wave 80% AM from 2000...2700 MHz

Environmental Specifications - 1756-HSC

Attribute	1756-HSC
EFT/B immunity IEC 61000-4-4	±4 kV at 5 kHz on power ports ±4 kV at 5 kHz on signal ports
Surge transient immunity IEC 61000-4-5	±1 kV line-line (DM) and ±2 kV line-earth (CM) on power ports ±1 kV line-line (DM) and ±2 kV line-earth (CM) on signal ports ±2 kV line-earth (CM) on shielded ports
Conducted RF immunity IEC 61000-4-6	10V rms with 1 kHz sine-wave 80% AM from 150 kHz...80 MHz on shielded signal ports

Certifications - 1756-HSC

Certification ⁽¹⁾	1756-HSC
UL	UL Listed Industrial Control Equipment, certified for US and Canada. See UL File E65584.
CSA	CSA Certified Process Control Equipment. See CSA File LR54689C. CSA Certified Process Control Equipment for Class I, Division 2 Group A,B,C,D Hazardous Locations. See CSA File LR69960C.
CE	European Union 2004/108/IEC EMC Directive, compliant with: <ul style="list-style-type: none"> • EN 61326-1; Meas./Control/Lab., Industrial Requirements • EN 61000-6-2; Industrial Immunity • EN 61000-6-4; Industrial Emissions • EN 61131-2; Programmable Controllers (Clause 8, Zone A & B) European Union 2006/95/EC LVD, compliant with: <ul style="list-style-type: none"> • EN 61131-2; Programmable Controllers (Clause 11)
C-Tick	Australian Radiocommunications Act, compliant with: AS/NZS CISPR 11; Industrial Emissions
Ex	European Union 94/9/EC ATEX Directive, compliant with: <ul style="list-style-type: none"> • EN 60079-15; Potentially Explosive Atmospheres, Protection "n" • EN 60079-0; General Requirements II 3 G Ex nA IIC T4 X

(1) When marked. See the Product Certification link at <http://www.ab.com> for Declarations of Conformity, Certificates, and other certification details.

1756-PLS

ControlLogix programmable limit switch module

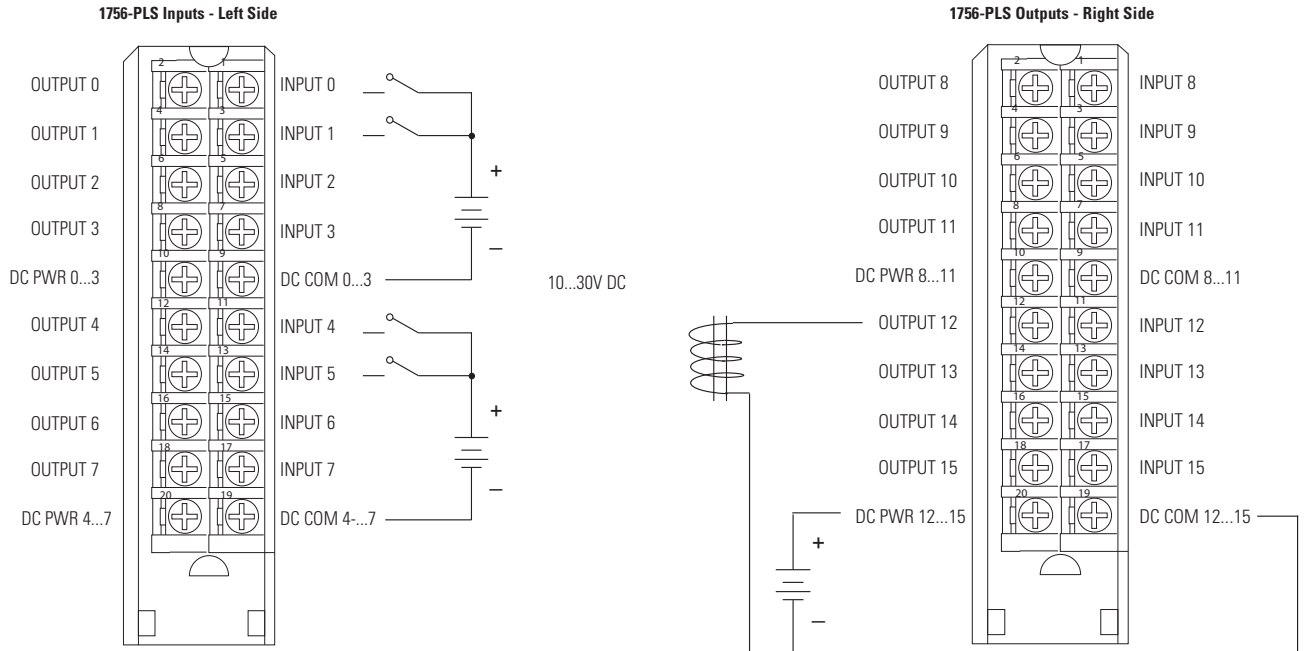

The 1756-PLS module supports enhanced packaging applications. The module requires three contiguous slots in the chassis.

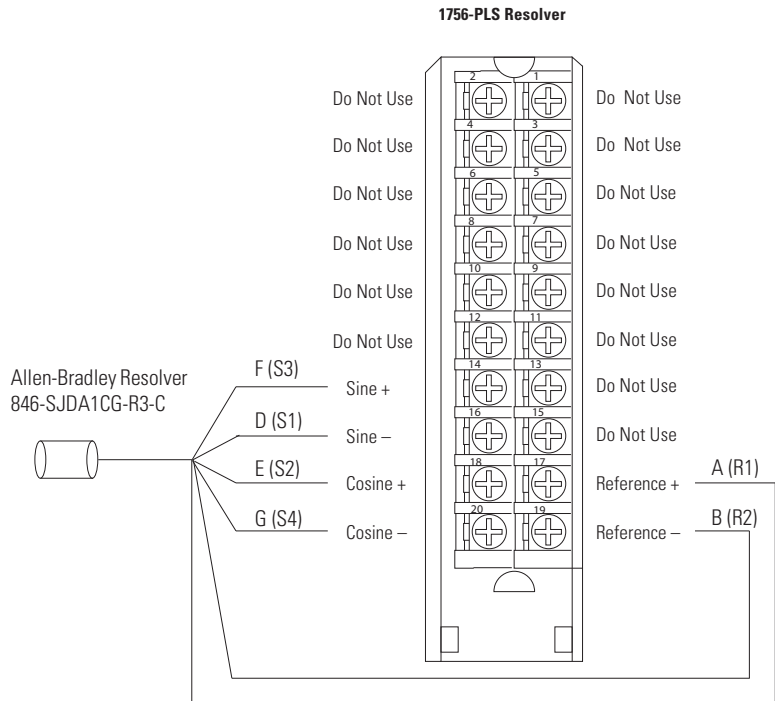

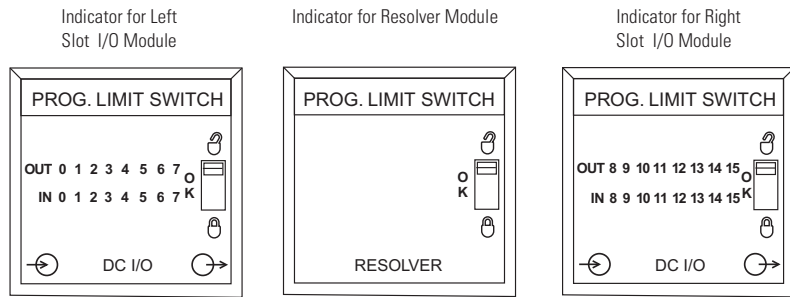

Technical Specifications - 1756-PLS

Attribute	1756-PLS
Module configuration	Left section: 2 groups of 4 outputs and 4 inputs each Center section: resolver interface and I/O control Right section: 2 groups of 4 outputs and 4 inputs each
Current draw at 5.1V	1 A
Current draw at 24V	125 mA
Total backplane power	8.1 W
Power dissipation, nom	22.62 W @ 30 °C (86 °F) 18.22 W @ 60 °C (140 °F)
Power dissipation, max	25.7 W @ 30 °C (86 °F) 21.3 W @ 60 °C (140 °F)
Thermal dissipation, nom	77.23 BTU/hr @ 30 °C (86 °F) 62.2 BTU/hr @ 60 °C (140 °F)
Thermal dissipation, max	87.74 BTU/hr @ 30 °C (86 °F) 72.72 BTU/hr @ 60 °C (140 °F)
Isolation voltage	250V (continuous), basic insulation type, I/O-to-backplane, I/O group-to-group, resolver-to-backplane, and resolver-to-I/O Routine tested at 1900V DC for 2 s
Removable terminal block	Requires 3 RTBs: 1756-TBNH or 1756-TBSH
RTB keying	User-defined mechanical
Slot width	3
Wire category	2 on signal ports 1 on power ports ⁽¹⁾
North American temperature code	T4
IEC temperature code	T4
Enclosure type	None (open style)

(1) Use this conductor category information for planning conductor routing as described in the system-level installation manual. See the Industrial Automation Wiring and Grounding Guidelines, publication [1770-4.1](#).

Resolver Specifications - 1756-PLS

Attribute	1756-PLS
Resolver location	Center section
Compatible resolver	Allen-Bradley resolver 846-SJxxxx-R3-x (x = customer options)
Resolver interface	2V rms, reference output (differential pair) 2V rms, sine and cosine inputs (2 differential pairs)
Reference voltage	2V rms ±20%

Resolver Specifications - 1756-PLS

Attribute	1756-PLS
Reference frequency	5 kHz \pm 20%
Digital resolution	12 bits (4096 counts from hardware)
Angular resolution	0.088 $^{\circ}$ /bit
Digital count range	0...4095 (decimal)
Maximum tracking rate	\pm 1800 RPM
Repeatability	\pm 0.0488% of full scale
Accuracy	\pm 0.0976% of full scale

Input Specifications - 1756-PLS

Attribute	1756-PLS
Inputs	16 (2 groups of 4 per I/O section)
Voltage category	12/24V DC
Operating voltage range	10.8...31.2V DC
Input delay time OFF to ON	< 15 μ s @ 30 $^{\circ}$ C (86 $^{\circ}$ F) < 150 μ s @ 60 $^{\circ}$ C (140 $^{\circ}$ F)
ON to OFF	< 30 μ s @ 30 $^{\circ}$ C (86 $^{\circ}$ F) < 200 μ s @ 60 $^{\circ}$ C (140 $^{\circ}$ F)
Power dissipation, inputs, nom	1.86 W @ 60 $^{\circ}$ C (140 $^{\circ}$ F)
Power dissipation, inputs, max	2.8 W @ 60 $^{\circ}$ C (140 $^{\circ}$ F)
Thermal dissipation, inputs, nom	6.35 BTU/hr
Thermal dissipation, inputs, max	9.56 BTU/hr
On-state voltage, min	10V DC
On-state voltage, nom	10.8...26.4V DC
On-state voltage, max	31.2V DC
Off-state voltage, max	5V DC
Off-state current, max	1.5 mA
On-state current, min	3 mA
On-state current, max	10 mA
Input impedance, max	3.3 k Ω @ 24V DC
Reverse polarity protection	Yes

Output Specifications - 1756-PLS

Attribute	1756-PLS
Outputs	16 (2 groups of 4 per I/O section)
Voltage category	12/24V DC
Operating voltage range	10...31.2V DC
Output delay time OFF to ON ON to OFF	< 15 μ s @ 60 °C (140 °F) < 25 μ s @ 60 °C (140 °F)
Power dissipation, outputs, nom	5.4 W @ 30 °C (86 °F) 3.2 W @ 60 °C (140 °F)
Power dissipation, outputs, max	6 W @ 30 °C (86 °F) 3.8 W @ 60 °C (140 °F)
Thermal dissipation, outputs, nom	18.43 BTU/hr @ 30 °C (86 °F) 10.93 BTU/hr @ 60 °C (140 °F)
Thermal dissipation, outputs, max	21.48 BTU/hr @ 30 °C (86 °F) 11.93 BTU/hr @ 60 °C (140 °F)
Output power dissipation/slot thermal dissipation	3.2 W @ 60 °C (140 °F) 10.93 BTU/hr @ 60 °C (140 °F)
Off-state leakage current per point, nom	<10 μ A @ 60 °C (140 °F)
Off-state leakage current per point, max	300 mA @ 60 °C (140 °F)
On-state voltage, min	10V DC
On-state voltage, nom	10.8...26.4V DC
On-state voltage, max	31.2V DC
Output voltage drop, max	0.55V DC
Current per point, max	1 A @ 30 °C ⁽¹⁾ (86 °F)
Current per group, max	4 A @ 30 °C ⁽²⁾ (86 °F)
Current per module, max	8 A @ 30 °C ⁽³⁾ (86 °F)
Current limit	< 4 A
Surge current per point	2 A for 10 ms every 1 s @ 60 °C (140 °F)
Load current per point, min	40 mA
Output switching time	Switching 1 A @ 24V DC
Short circuit protection	Electronic (No indication of fault. Remove load and toggle on/off to restore.)
Reverse polarity protection	Yes, current limited. (If wired incorrectly, outputs may be permanently disabled.)

(1) Derate 16.7 mA/ °C above 30 °C (86 °F): 0.5 A @ 60 °C (140 °F).

(2) Derate 66.8 mA/ °C above 30 °C (86 °F): 2 A @ 60 °C (140 °F).

(3) Derate 133.6 mA/ °C above 30 °C (86 °F): 4 A @ 60 °C (140 °F).

Environmental Specifications - 1756-PLS

Attribute	1756-PLS
Temperature, operating IEC 60068-2-1 (Test Ad, Operating Cold), IEC 60068-2-2 (Test Bd, Operating Dry Heat), IEC 60068-2-14 (Test Nb, Operating Thermal Shock)	0...60 °C (32...140 °F)
Temperature, surrounding air, max	60 °C (140 °F)
Temperature, storage IEC 60068-2-1 (Test Ab, Unpackaged Nonoperating Cold), IEC 60068-2-2 (Test Bb, Unpackaged Nonoperating Dry Heat), IEC 60068-2-14 (Test Na, Unpackaged Nonoperating Thermal Shock)	-40...85 °C (-40...185 °F)
Relative humidity IEC 60068-2-30 (Test Db, Unpackaged Nonoperating Damp Heat)	5...95% noncondensing
Vibration IEC 60068-2-6 (Test Fc, Operating)	2 g @ 10...500 Hz
Shock, operating IEC 60068-2-27 (Test Ea, Unpackaged Shock)	30 g
Shock, nonoperating IEC 60068-2-27 (Test Ea, Unpackaged Shock)	50 g
Emissions	CISPR 11: Group 1, Class A
ESD immunity IEC 61000-4-2	6 kV contact discharges 8 kV air discharges
Radiated RF immunity IEC 61000-4-3	10V/m with 1 kHz sine-wave 80% AM from 80...2000 MHz 10V/m with 200 Hz 50% Pulse 100% AM @ 900 MHz 10V/m with 200Hz 50% Pulse 100% AM @ 1890 MHz 3V/m with 1 kHz sine-wave 80% AM from 2000...2700 MHz
EFT/B immunity IEC 61000-4-4	±4 kV at 5 kHz on unshielded I/O and power ports ±2 kV at 5 kHz on shielded resolver ports
Surge transient immunity IEC 61000-4-5	±1 kV line-line (DM) and ±2 kV line-earth (CM) on unshielded I/O and power ports ±2 kV line-earth (CM) on shielded resolver ports
Conducted RF immunity IEC 61000-4-6	10V rms with 1 kHz sine-wave 80% AM from 150 kHz...80 MHz on shielded signal ports

Certifications - 1756-PLS

Certification ⁽¹⁾	1756-PLS
UL	UL Listed Industrial Control Equipment, certified for US and Canada. See UL File E65584.
CSA	CSA Certified Process Control Equipment. See CSA File LR54689C. CSA Certified Process Control Equipment for Class I, Division 2 Group A,B,C,D Hazardous Locations. See CSA File LR69960C.
CE	European Union 2004/108/IEC EMC Directive, compliant with: <ul style="list-style-type: none"> • EN 61326-1; Meas./Control/Lab., Industrial Requirements • EN 61000-6-2; Industrial Immunity • EN 61000-6-4; Industrial Emissions • EN 61131-2; Programmable Controllers (Clause 8, Zone A & B) European Union 2006/95/EC LVD, compliant with: <ul style="list-style-type: none"> • EN 61131-2; Programmable Controllers (Clause 11)
C-Tick	Australian Radiocommunications Act, compliant with: AS/NZS CISPR 11; Industrial Emissions
Ex	European Union 94/9/EC ATEX Directive, compliant with: <ul style="list-style-type: none"> • EN 60079-15; Potentially Explosive Atmospheres, Protection "n" • EN 60079-0; General Requirements II 3 G Ex nA IIC T4 X

(1) When marked. See the Product Certification link at <http://www.ab.com> for Declarations of Conformity, Certificates, and other certification details.

ControlLogix I/O Accessories

Place 1756 I/O modules in any slot in a 1756 chassis. Each chassis requires a power supply.

Product	Cat. No.
Chassis	1756-A4, 1756-A7, 1756-A10, 1756-A13, 1756-A17
Power supply, standard	1756-PA72/C, 1756-PA75/B, 1756-PB72/C, 1756-PB75/B, 1756-PC75/B, 1756-PH75/B
Power supply, redundant	1756-PA75R, 1756-PB75R, 1756-PSCA2 1756-CPR2 cable

For more information on chassis, see ControlLogix Chassis Specifications Technical Data, publication [1756-TD006](#).

For more information on power supplies, see ControlLogix Power Supply Specifications Technical Data, publication [1756-TD005](#).



1756 Removable Terminal Blocks

Removable terminal blocks (RTBs) provide a flexible interconnection between your plant wiring and 1756 I/O modules. The RTB plugs into the front of the I/O module. The type of module determines which RTB you need. You can choose screw-clamp or spring-clamp RTBs.

RTBs are not shipped with I/O modules. You must order them separately. The standard housing on the front of the wiring arm is not deep enough for 2.5 mm² (14 AWG) wiring. If you plan to use 2.5 mm² (14 AWG) wiring, also order the extended housing.



ATTENTION: If separate power sources are used, do not exceed the specified isolation voltage: referring to each individual module's specifications on the preceding pages.

RTB Specifications - 1756-TBNH, 1756-TBSH, 1756-TBCH, 1756-TBS6H, 1756-TBE

Attribute	1756-TBNH	1756-TBSH	1756-TBCH	1756-TBS6H	1756-TBE
Description	20-position NEMA screw-clamp removable block	20-pin spring-clamp removable terminal block with standard housing	36-pin cage-clamp removable terminal block with standard housing	36-pin spring-clamp removable terminal block with standard housing	Extended depth terminal block housing
Screw torque	1.36 N•m (12 lb•in)	N/A	0.5 N•m (4.4 lb•in)	N/A	N/A
Wire size ⁽¹⁾	0.33...2.1 mm ² (22...14 AWG) solid or stranded copper wire rated at 90 °C (194 °F), or greater, 1.2 mm (3/64 in.) insulation max Do not wire more than two conductors on any single terminal.	0.33...2.1 mm ² (22...14 AWG) solid or stranded copper wire rated at 90 °C (194 °F), or greater, 1.2 mm (3/64 in.) insulation max Do not wire more than two conductors on any single terminal.	Single wire connection: 0.33...2.1 mm ² (22...14 AWG) solid or stranded copper wire rated at 90 °C (194 °F), or greater, 1.2 mm (3/64 in.) insulation max Double wire connection: 0.33...1.3 mm ² (22...16 AWG) solid or stranded copper wire rated at 90 °C (194 °F), or greater, 1.2 mm (3/64 in.) insulation max Do not wire more than two conductors on any single terminal.	0.33...2.1 mm ² (22...14 AWG) solid or stranded copper wire rated at 90 °C (194 °F), or greater, 1.2 mm (3/64 in.) insulation max Do not wire more than two conductors on any single terminal.	
Screwdriver width	8 mm (5/16 in.) max	N/A	3.2 mm (1/8 in.)	N/A	N/A

(1) Maximum wire size requires extended housing, catalog number 1756-TBE.

Wiring Systems

As an alternative to buying RTBs and connecting the wires yourself, you can buy a wiring system of:



- interface modules (IFMs) that provide the output terminal blocks for digital I/O modules. Use the pre-wired cables that match the I/O module to the IFM.
- analog interface modules (AIFMs) that provide the output terminal blocks for analog I/O modules. Use the pre-wired cables that match the I/O module to the AIFM.
- I/O module-ready cables. One end of the cable assembly is an RTB that plugs into the front of the I/O module. The other end has individually color-coded conductors that connect to a standard terminal block.

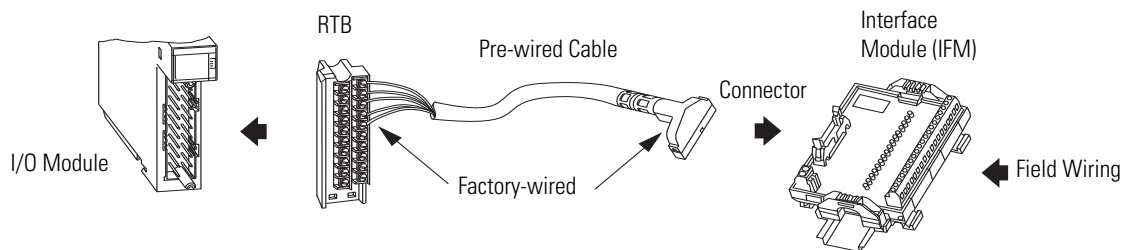

Important User Information

Solid-state equipment has operational characteristics differing from those of electromechanical equipment. Safety Guidelines for the Application, Installation and Maintenance of Solid State Controls (publication [SGI-1.1](#) available from your local Rockwell Automation sales office or online at <http://www.rockwellautomation.com/literature/>) describes some important differences between solid-state equipment and hard-wired electromechanical devices. Because of this difference, and also because of the wide variety of uses for solid-state equipment, all persons responsible for applying this equipment must satisfy themselves that each intended application of this equipment is acceptable.

In no event will Rockwell Automation, Inc. be responsible or liable for indirect or consequential damages resulting from the use or application of this equipment.

The examples and diagrams in this manual are included solely for illustrative purposes. Because of the many variables and requirements associated with any particular installation, Rockwell Automation, Inc. cannot assume responsibility or liability for actual use based on the examples and diagrams.

No patent liability is assumed by Rockwell Automation, Inc. with respect to use of information, circuits, equipment, or software described in this manual.

Reproduction of the contents of this manual, in whole or in part, without written permission of Rockwell Automation, Inc., is prohibited.

Documentation Feedback

Your comments will help us serve your documentation needs better. If you have any suggestions on how to improve this document, complete this form, publication [RA-DU002](#), available at <http://www.rockwellautomation.com/literature/>.

Rockwell Automation, Rockwell Software, Allen-Bradley, ControlLogix, GuardLogix, and RSLogix 5000 are trademarks of Rockwell Automation, Inc.

Trademarks not belonging to Rockwell Automation are property of their respective companies.

Rockwell Otomasyon Ticaret A.Ş., Kar Plaza İş Merkezi E Blok Kat:6 34752 İçerenköy, İstanbul, Tel: +90 (216) 5698400

www.rockwellautomation.com

Power, Control and Information Solutions Headquarters

Americas: Rockwell Automation, 1201 South Second Street, Milwaukee, WI 53204-2496 USA, Tel: (1) 414.382.2000, Fax: (1) 414.382.4444

Europe/Middle East/Africa: Rockwell Automation NV, Pegasus Park, De Kleetlaan 12a, 1831 Diegem, Belgium, Tel: (32) 2 663 0600, Fax: (32) 2 663 0640

Asia Pacific: Rockwell Automation, Level 14, Core F, Cyberport 3, 100 Cyberport Road, Hong Kong, Tel: (852) 2887 4788, Fax: (852) 2508 1846

Publication 1756-TD002D-EN-E - June 2011

Supersedes Publication 1756-TD002C-EN-E - September 2010

Copyright © 2011 Rockwell Automation, Inc. All rights reserved. Printed in the U.S.A.