

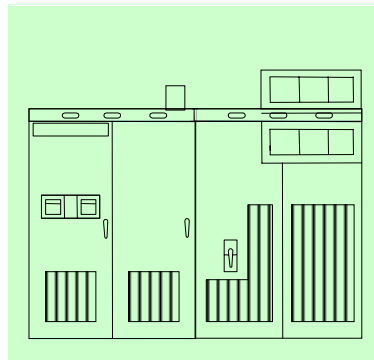

GEH-6632

GE Industrial Systems

EX2100

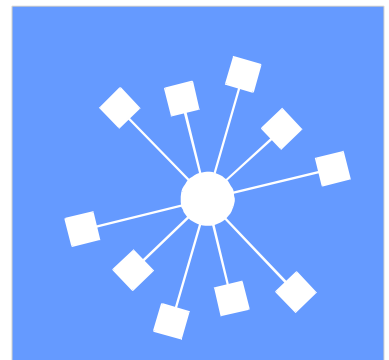

EX2100TM Excitation Control

User's Guide



Document: GEH-6632
Issue Date: 2000-09-30

EX2100

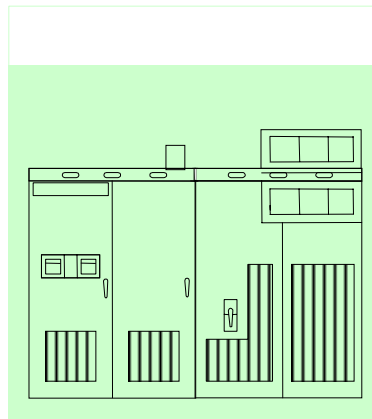
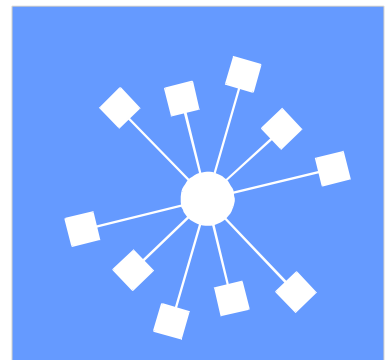

EX2100TM Excitation Control

User's Guide

© 2000 General Electric Company, USA.
All rights reserved.

Printed in the United States of America.

These instructions do not purport to cover all details or variations in equipment, nor to provide for every possible contingency to be met during installation, operation, and maintenance. If further information is desired or if particular problems arise that are not covered sufficiently for the purchaser's purpose, the matter should be referred to GE Industrial Systems, Salem, Virginia, USA.

This document contains proprietary information of General Electric Company, USA and is furnished to its customer solely to assist that customer in the installation, testing, operation, and/or maintenance of the equipment described. This document shall not be reproduced in whole or in part nor shall its contents be disclosed to any third party without the written approval of GE Industrial Systems.

Document Identification: GEH-6632

EX2100 is a trademark of General Electric Company, USA.
Cimplicity® is a registered trademark of GE Fanuc Automation North America, Inc.
Ethernet™ is a trademark of Xerox Corporation.
Mate-N-Lok® is a registered trademark of Amp Incorporated.
Windows NT® is a registered trademark of Microsoft Corporation.

Safety Symbol Legend



Indicates a procedure, condition, or statement that, if not strictly observed, could result in personal injury or death.

Warning



Indicates a procedure, condition, or statement that, if not strictly observed, could result in damage to or destruction of equipment.

Caution

Note Indicates an essential or important procedure, condition, or statement.



Warning

This equipment contains a potential hazard of electric shock or burn. Only personnel who are adequately trained and thoroughly familiar with the equipment and the instructions should install, operate, or maintain this equipment.

Isolation of test equipment from the equipment under test presents potential electrical hazards. If the test equipment cannot be grounded to the equipment under test, the test equipment's case must be shielded to prevent contact by personnel.

To minimize hazard of electrical shock or burn, approved grounding practices and procedures must be strictly followed.



Warning

To prevent personal injury or equipment damage caused by equipment malfunction, only adequately trained personnel should modify any programmable machine.



Reader Comments

General Electric Company

To:
GE Industrial Systems
Documentation Design, Rm. 291
1501 Roanoke Blvd.
Salem, VA 24153-6492 USA
Fax: 1-540-387-8651
(GE Internal DC 8-278-8651)

We welcome comments and suggestions to make this publication more useful.

Your Name	Today's Date	If needed, how can we contact you?
Your Company's Name and Address	Job Site	Fax No. _____
	GE Requisition No.	Phone No. _____
Your Job Function / How You Use This Publication	Publication No.	E-mail _____
	Publication Issue/Revision Date	Address _____

General Rating

	Excellent	Good	Fair	Poor	Additional Comments
Contents	<input type="radio"/>	<input type="radio"/>	<input type="radio"/>	<input type="radio"/>	_____
Organization	<input type="radio"/>	<input type="radio"/>	<input type="radio"/>	<input type="radio"/>	_____
Technical Accuracy	<input type="radio"/>	<input type="radio"/>	<input type="radio"/>	<input type="radio"/>	_____
Clarity	<input type="radio"/>	<input type="radio"/>	<input type="radio"/>	<input type="radio"/>	_____
Completeness	<input type="radio"/>	<input type="radio"/>	<input type="radio"/>	<input type="radio"/>	_____
Drawings / Figures	<input type="radio"/>	<input type="radio"/>	<input type="radio"/>	<input type="radio"/>	_____
Tables	<input type="radio"/>	<input type="radio"/>	<input type="radio"/>	<input type="radio"/>	_____
Referencing	<input type="radio"/>	<input type="radio"/>	<input type="radio"/>	<input type="radio"/>	_____
Readability	<input type="radio"/>	<input type="radio"/>	<input type="radio"/>	<input type="radio"/>	_____

Specific Suggestions (Corrections, information that could be expanded on, and such.)

Page No. Comments

_____	_____
_____	_____
_____	_____
_____	_____
_____	_____
_____	_____

Other Comments (What you like, what could be added, how to improve, and such.)

Overall grade (Compared to publications from other manufacturers of similar products, how do you rate this publication?)

Superior Comparable Inferior Do not know Comment _____

Detach and fax or mail to the address noted above.

.....Fold here and close with staple or tape

Place
stamp
here.

GE Industrial Systems
Documentation Design, Rm. 291
1501 Roanoke Blvd.
Salem, VA 24153-6492 USA

.....Fold here first.....

Contents

Chapter 1 Equipment Overview 1-1

- Introduction 1-1
- System Overview 1-2
- Hardware Overview 1-5
- Software Overview..... 1-6
- Technical Characteristics 1-6
- How to Get Help 1-8
- Related Documents 1-8
 - Document Distribution..... 1-8

Chapter 2 Functional Description 2-1

- Introduction 2-1
- Exciter Hardware 2-2
- Exciter Configurations 2-3
- Power Conversion Cabinet..... 2-5
 - Manual Ac Disconnect (Optional) 2-5
 - Power Conversion Module (PCM) 2-5
 - Gate Pulse Amplifiers (EGPA Board) 2-6
 - Main Dc Contactors. 41A or 41A/41B (Optional)..... 2-7
 - Free Wheeling Diode De-excitation 2-7
- Auxiliary Cabinet 2-8
 - Ac Line-to-Line Filters 2-8
 - De-excitation Module (EDEX) 2-8
 - Shaft Voltage Suppressor..... 2-9
 - Field Flashing Module 2-9
 - Field Ground Detector (EXAM and EGDM)..... 2-9
 - High Voltage Interface – HVI..... 2-9
- Control Cabinet 2-10
 - Diagnostic Interface (Keypad) 2-10
 - Control Module..... 2-11
 - Simplex Control System 2-12
 - Redundant Control System 2-13
 - Control Power Supplies 2-14
- Exciter Software..... 2-17
 - Auto Reference – AUTO REF 2-20
 - AVR Setpoint – EXASP 2-20
 - Automatic Voltage Regulator – AVR 2-20
 - Manual Reference – MANUAL REF 2-21
 - Field Voltage and Current Regulators - FVR & FCR..... 2-21
 - Under Excitation Limiter – UEL 2-22
 - Power System Stabilizer – PSS..... 2-22
- Operator Interface 2-23
 - Turbine Control HMI..... 2-23
 - Control System Toolbox (toolbox)..... 2-23

Chapter 3 Printed Wiring Boards Overview 3-1

Introduction	3-1
Control Boards	3-2
Exciter Backplane (EBKP)	3-2
Digital Signal Processor Board (DSPX)	3-2
ACLA Board	3-4
EISB Board	3-4
EMIO Board	3-4
ESEL Board	3-5
I/O Terminal Boards	3-5
EPCT Board	3-5
ECTB Board	3-6
EXTB Board	3-6
EDCF Board	3-6
EACF Board	3-7
Bridge and Protection Boards and Modules	3-7
EGPA Board	3-7
EXCS Board	3-7
EDEX Board	3-8
EGDM Module	3-8
EXAM Module	3-9
Power Supply Boards	3-9
EPDM Module	3-9
EPBP Backplane	3-9
EPSM Module	3-11
DACA – Ac to Dc Converter	3-11
Related Board Publications	3-11

Chapter 4 Terminal Board I/O and Equipment Connections 4-1

Introduction	4-1
Power Connections and Analog I/O	4-2
Power Potential Transformer Inputs	4-3
Potential and Current Transformer Inputs	4-3
Analog Input	4-3
Customer Contact I/O	4-4
Power Supply Inputs	4-6
Line Filter Connections	4-7
Exciter Internal I/O	4-8
Exciter AC Feedback	4-8
Exciter DC Feedback	4-8
De-Excitation	4-11
Crowbar	4-14
Field Ground Detector	4-14
Field Flashing	4-16
Dc Field Flashing Settings	4-16
Flashing Control Sequence	4-16
Shaft Voltage Suppressor	4-18
Data Highway Connections	4-19
Control System Toolbox Connection	4-20

Chapter 5 Diagnostic Interface-Keypad 5-1

Introduction	5-1
Using the Pushbuttons	5-2
Reading the Display	5-5

Changing Display Units	5-7
Adjusting Display Contrast	5-7
Status Screen	5-8
Reading the Meters	5-8
Alternate Status Screen (Display I/O)	5-8
Using the Menus	5-9
Viewing and Resetting Faults	5-9
Editing Parameters	5-10
Parameter Backup	5-11
Firmware and Hardware Information	5-13
Protecting the Keypad	5-14
Modifying the Protections	5-14

Appendix A Warranty and Renewal Parts A-1

Introduction	A-1
Identifying the Part	A-2
Renewal Parts List	A-2
Part Number Structure	A-2
Warranty Terms	A-4
How to Order Parts	A-5
Data Nameplate	A-5
ML Number	A-5

Appendix B Ratings and Specifications B-1

Glossary of Terms

Index

Notes

Chapter 1 Equipment Overview

Introduction

The EX2100™ Excitation Control (EX2100 *or* exciter) produces the field excitation current to control generator ac terminal voltage and/or the reactive volt-amperes. It is a full static excitation system designed for generators on both new and retrofit steam, gas, and hydro turbines.

This chapter introduces the exciter and defines the document contents. Its purpose is to present a general product overview as follows:

Section/Topic	Page
System Overview	1-2
Hardware Overview	1-5
Software Overview	1-6
Technical Characteristics	1-6
How to Get Help	1-8
Related Documents	1-8
Document Distribution	1-8
Chapter 2 Functional Description	
Chapter 3 Printed Wiring Boards Overview	
Chapter 4 Terminal Boards I/O and Equipment Connections	
Chapter 5 Diagnostic Interface (Keypad)	
Appendix A Warranty and Renewal Parts	
Appendix B Ratings and Specifications	
Glossary	

System Overview

The exciter is a flexible modular system that can be assembled to provide a range of available output currents and several levels of system redundancy. These options include power from a potential, compound, or auxiliary source. Single or multiple bridges, warm backup bridges, and simplex or redundant controls are available. An overview of the turbine generator excitation system is shown in Figure 1-1.

Power for the exciter is drawn from a power potential transformer connected to the generator terminals, or from an excitation transformer connected to an auxiliary bus. Generator line current and stator output voltage are the primary feedbacks to the exciter, and dc voltage and current is the controlled output to the exciter field.

The architecture supports Ethernet LAN (Unit Data Highway) communication with other GE equipment including the GE Control System Toolbox (toolbox) for configuration, the turbine control, the LCI Static Starter, and the HMI (operator interface).

Figure 1-2 is a simplified one line diagram of the exciter showing the power source, generator current and voltage measurements, control module, power conversion module (PCM), and protection circuits. In the potential source system, the secondary of the PPT is connected to the input of a 3-phase full-wave inverting thyristor bridge. The inverting bridge provides both positive and negative forcing voltage for optimum performance. Negative forcing provides fast response for load rejection and de-excitation.

Either simplex or redundant control is available.

Excitation control results from phase controlling the output of the SCR bridge circuit. The SCR firing signals are generated by digital regulators in the controller. In the redundant control option (Figure 1-2), either M1 or M2 can be the active master control, while C monitors both to determine which should be the active and which the standby controller. Dual independent firing circuits and automatic tracking is used to ensure a smooth transfer to the standby controller.

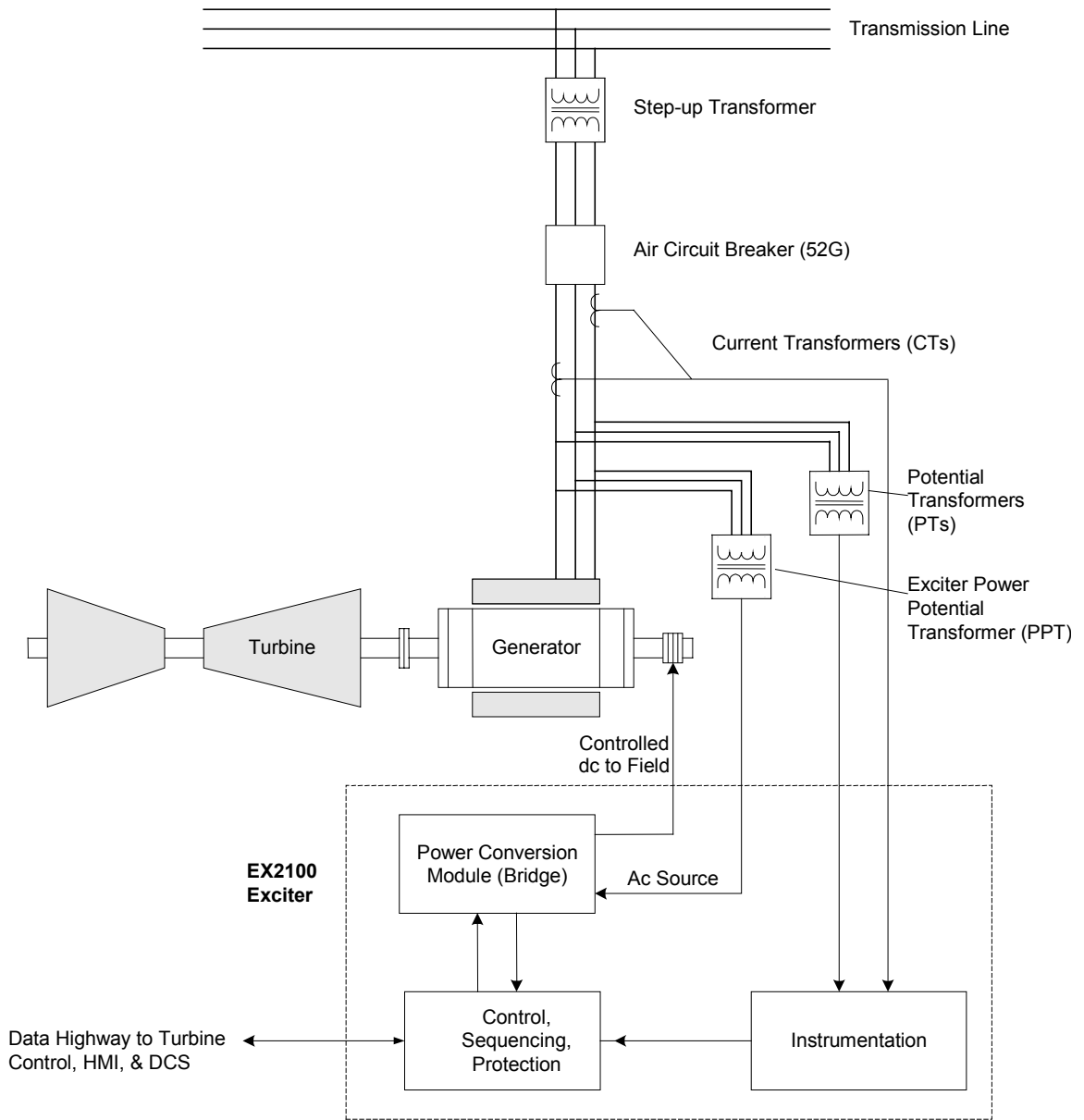

Figure 1-1 Overview of Generator and Exciter System

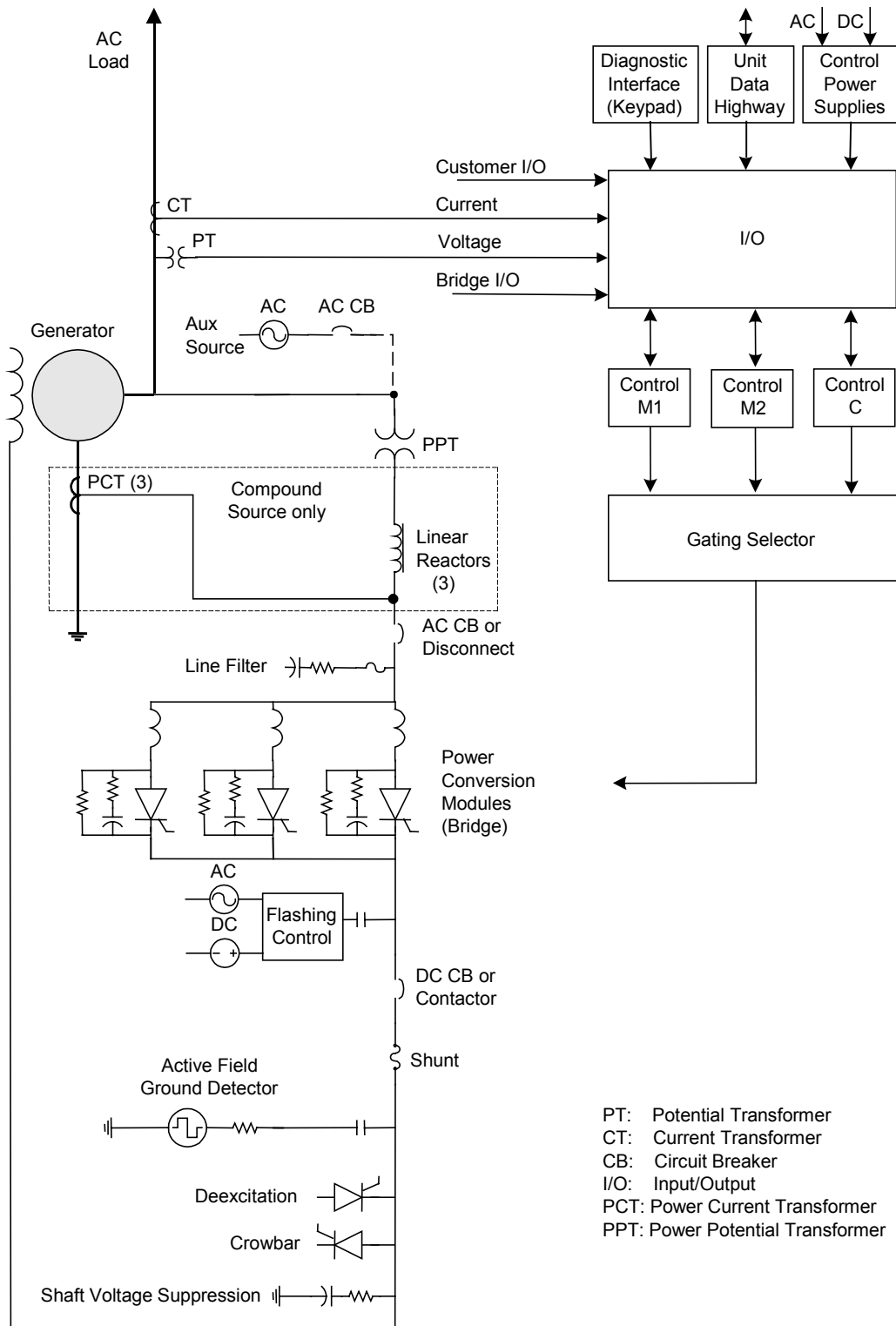

Figure 1-2. Exciter One Line Diagram

Hardware Overview

The EX2100 hardware is contained in three cabinets as follows:

- control cabinet for the control, communication, and I/O boards
- auxiliary cabinet for field flashing and protection circuits such as de-excitation and shaft voltage suppression
- power conversion cabinet for the power SCR cells, cooling fans, dc contactors, and ac disconnect

The exciter's power converter consists of bridge rectifiers, resistor/capacitor filter configurations, and control circuitry. An outside view of the cabinets is shown in Figure 1-3. The components and bridge size vary for different excitation systems and for the power output required.

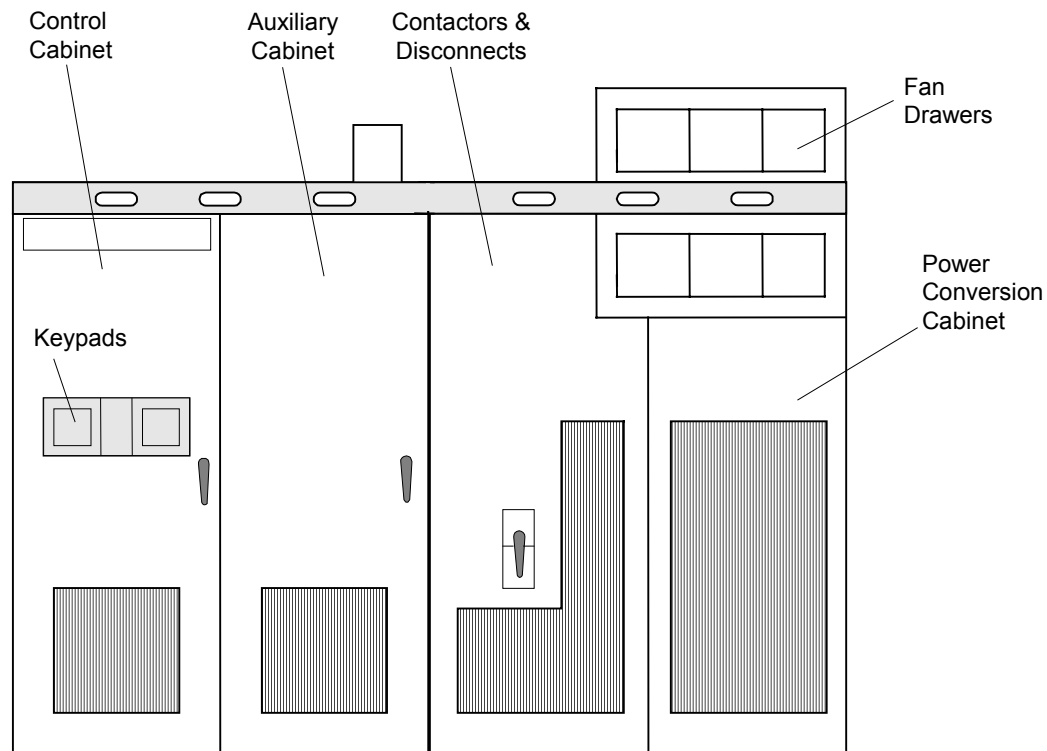

Figure 1-3. Exciter Cabinets

Software Overview

Microprocessor-based controllers (ACLA and DSPX) execute the exciter control code. The software consists of modules (blocks) combined to create the required system functionality. Block definitions and configuration parameters are stored in flash memory, while variables are stored in random-access memory (RAM).

The exciter application software emulates traditional analog controls. It uses an open architecture system, with a library of existing software blocks configured from the toolbox. The blocks individually perform specific functions, such as logic gates, proportional integral (P.I.) regulators, function generators, and signal level detectors. The control selects one of two modes, either generator voltage regulation (Auto Regulation), or direct control (voltage or current, depending upon the application). Generator protection functions are integrated into the control, including over and under-excitation limiting, power system stabilization, and V/Hz limiting.

The blocks can be interrogated while the exciter is running by using the toolbox. The dynamically changing I/O values of each block can be observed in operation, which is valuable during startup or troubleshooting.

Technical Characteristics

Summary characteristics for the EX2100 are as follows; for further details refer to Appendix B.



Caution

Unit Specific ratings are provided on equipment nameplate and supercede all information herein.

EX2100 Characteristics	Description
Power Converter Module (PCM)	
Single bridge rating	1,000 and 2,000 A dc at up to 1,000 V ac
Parallel bridge rating	8,000 A dc at up to 1,500 V ac; with up to 6 bridges
Forcing requirements	150% of design Amperes (EDA) for 30 s at 40 °C
Power Sources	
Power for the PCM – Voltage source	Auxiliary bus Generator terminals Compound source 600 or 1,000 V ac versions
Power Input for the PCM - VA	3251 kVA (1,000 V version)
Power for the PCM - Frequency	3-phase 50/60 Hz
Flashing power	Battery source 125 V dc or 250 V dc, with up to 200 A for at least 10 s 240 or 480 V ac, 50/60 Hz single-phase auxiliary source
Control power	For two ac sources, or one ac and one dc source: Nominal 120 V ac $\pm 15\%$, with 1 DACA, 10 A rms max. Battery source, 125 V dc, range 80 – 140 V dc, 10.6 A dc max.

Input/Output	QTY	
Potential transformers (PTs)	2	3-phase standard, single phase available 120 V ac nominal 1 VA nominal burden
Current transformers (CTs, 1 or 5 A)	2	Any two phases, single phase available 1 VA nominal burden
86G dedicated contact input	1	open for trip
52G dedicated contact input	1	closed for online
Trip rated contact outputs	2	At 125 V dc with relay break characteristics: Resistive load 0.5 A Inductive load 0.2 A
General Purpose contact inputs	6	Customer contacts, 70 V dc supplied by ECTB
General Purpose Form C contact outputs	4	At 125 V dc with relay break characteristics: Resistive load 0.5 A Inductive load 0.1 A
± 10 V differential amplifier input	1	
Thermal		
Base controls cabinet		Continuous operation in a 0 to 40 °C ambient environment, with 5 to 95% humidity, non-condensing
Base power conversion and auxiliary cabinet		Continuous operation in a 0 to 40 °C ambient environment, with 5 to 95% humidity, non-condensing
Cabinet Dimensions & Weight		
Redundant control with dual PCM redundant converter in a three-cabinet lineup	Width	141.74 in (3600 mm)
	Height	104.32 in (2650 mm)
	Depth	31.5 in (800 mm)
Weight of Converter cabinet		3,600 lbs
Weight of Total Lineup (Converter, Control, and Auxiliary cabinets)		5,600 lbs
Cabinet type, control & auxiliary enclosures		NEMA 1 (IEC IP 20), convection cooled
Cabinet type, power conversion		NEMA 1 (IEC IP 20), forced air cooled
Power and Control Cable Access		Entrances from the top and/or bottom

How to Get Help

“+” indicates the international access code required when calling from outside of the USA.

If help is needed beyond the instructions provided in the drive system documentation, contact GE as follows:

GE Industrial Systems
Product Service Engineering
1501 Roanoke Blvd.
Salem, VA 24153-6492 USA
Phone: + 1 888 GE4 SERV (888 434 7378, United States)
+ 1 540 378 3280 (International)
Fax: + 1 540 387 8606 (All)

Related Documents

The following documents also apply to the exciter and may assist in understanding the system.

GEI-100256C EX2100 Receiving, Storage, & Handling

GEH-6631 EX2100 Installation and Startup Guide

GEH-6633 EX2100 Troubleshooting, Preventive and Online Maintenance

GEH-6403 Control System Toolbox for Mark VI Turbine Controller

Printed Wiring Board (GEI) publications, refer to Chapter 3.

Document Distribution

GE Industrial Systems supplies product documents to its customers to support the equipment provided for each requisition. The contract documents define the terms of the document distribution.

If provided (per contract) the following documents contain requisition information about the drive system.

- Requisition drawings, including outlines, layouts, and elementary diagrams
- Renewal parts listing

Note If differences exist between the general product documentation and the requisition documentation, the requisition documentation should be considered the more exact representation of your equipment or system configuration.

Chapter 2 Functional Description

Introduction

This chapter describes the function of the EX2100 static exciter and the individual control and protection circuits. Power supplies and the distribution of power is also covered. The functional description information is organized as follows:

Section	Page
Exciter Hardware	2-2
Exciter Configurations	2-3
Power Conversion Cabinet	2-5
Manual Ac Disconnect (Optional)	2-5
Power Converter Module (PCM)	2-5
Gate Pulse Amplifiers (EGPA Board)	2-6
Main Dc Contactors. 41A or 41A/41B (Optional)	2-7
Free Wheeling Diode De-excitation	2-7
Auxiliary Cabinet	2-8
Ac Line-to-Line Filters	2-8
De-excitation Module (EDEX)	2-8
Shaft Voltage Suppressor	2-9
Field Flashing Module	2-9
Field Ground Detector (EXAM and EGDM)	2-9
High Voltage Interface – HVI	2-9
Control Cabinet	2-10
Diagnostic Interface (Keyad)	2-10
Control Module	2-11
Simplex Control System	2-12
Redundant Control System	2-13
Control Power Supplies	2-14
Exciter Software	2-17
Auto Reference – AUTO REF	2-20
AVR Setpoint – EXASP	2-20
Automatic Voltage Regulator – AVR	2-20
Manual Reference – MANUAL REF	2-21
Field Voltage and Current Regulators - FVR & FCR	2-21
Under Excitation Limiter – UEL	2-22
Power System Stabilizer – PSS	2-22
Human Machine Interface (HMI)	2-23
Mark VI HMI	2-23
Toolbox	2-23

Exciter Hardware

The EX2100 exciter consists of the following basic components.

- Power Conversion Module (PCM) and cooling fans
- Power potential transformer (PPT) (mounted separate from exciter)
- Line-to-line filters
- Shaft voltage suppressor
- De-excitation module
- Diagnostic Interface (keypad)
- Controllers and I/O boards
- Control power supplies

Optional components that can be added to the exciter are:

- Warm backup bridge configuration
- Multibrige configuration for high current requirements
- Compound power source (separate from exciter)
- Auxiliary power source (bus-fed)
- Crowbar module (for hydro and other special applications)
- Dc Disconnect
- Field ground detector
- Redundant ac source for power supply
- Ac disconnect
- Field flashing module
- Redundant controllers providing a Triple Modular Redundant (TMR) system
- GE Control System Toolbox (toolbox) for configuration

The control hardware is basically the same for the different types of excitation. The power conversion hardware is defined by application requirements, which therefore determines the exciter bridge size.

Exciter Configurations

EX2100 Exciters can be supplied with single or redundant control, and with single or redundant bridges. Variations of the single control type are shown in Figure 2-1.

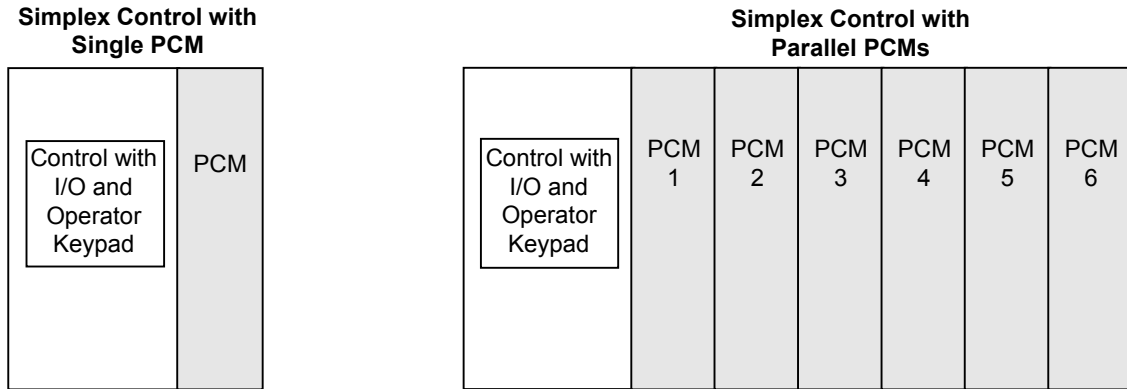

Figure 2-1. Simplex Control Configurations

Exciters with dual (redundant) control are shown in Figure 2-2. Multiple PCMs can be supplied in simplex, warm backup, or redundant n+1 or n+2 modes (with n+1 or n+2 equal to 6).

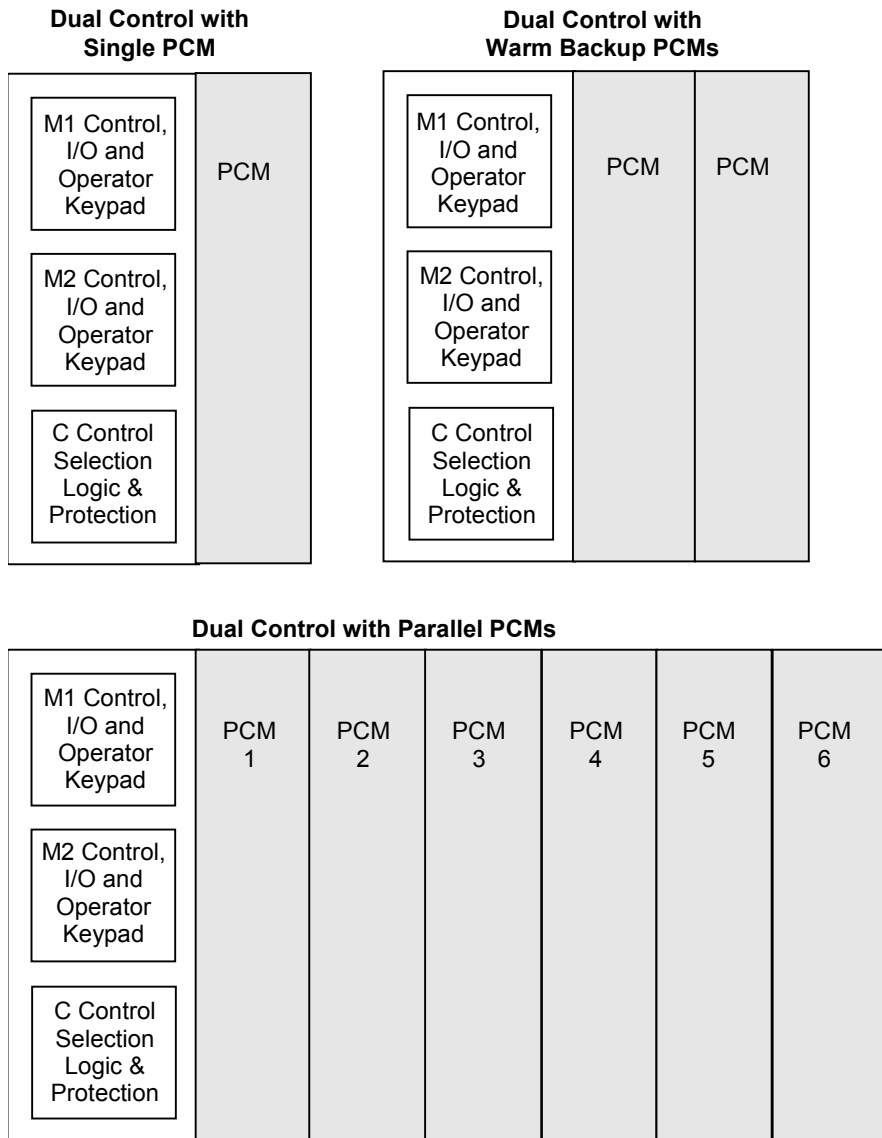

Figure 2-2. Dual Control System Configurations

Power Conversion Cabinet

The Power Conversion cabinet contains the Power Conversion Module (PCM), the Exciter Gate Pulse Amplifier (EGPA) board, ac circuit breaker, and the dc circuit contactor. Three-phase power for the PCM comes from a PPT external to the exciter. The ac supply comes into the cabinet through the ac circuit breaker (if supplied), and is filtered by 3-phase line filters in the auxiliary cabinet.

Manual Ac Disconnect (Optional)

The manual ac disconnect switch serves as a disconnect device between the secondary of the power potential transformer and the static exciter. It is a molded case, 3-phase, non-automatic, panel-mounted switch, which is manually operated for isolating the ac input supply. It is a no-load disconnect device.

Power Conversion Module (PCM)

The exciter PCM includes the bridge rectifiers, dc leg fuses, thyristor protection circuitry (for example, snubbers, filters, and fuses) and leg reactor assemblies. The components vary for different bridge ratings based on the power output required.

Bridge Rectifier

Each bridge rectifier is a 3-phase full-wave thyristor bridge. The bridge has six SCRs (thyristors) controlled by the Exciter Gate Pulse Amplifier board (EGPA) as shown in Figure 2-3. Heat is dissipated through large aluminum cooling fins and forced air flow from overhead fans.

Leg Reactors and Cell Snubbers

The commutating reactors are located in the ac legs feeding the SCRs, and the snubbers are an RC circuit from the anode to the cathode of each SCR. The cell snubbers, line-to-line snubbers and line reactors together perform the following functions to prevent misoperation of the SCRs.

- Limit the rate of change of current through the SCRs and provide a current *dump* to aid in starting conduction.
- Limit the rate of change in voltage across the cell and, during cell commutation, limit the reverse voltage that occurs across the cell.

The SCR snubbers include PRV resistors to limit the peak reverse voltage. These resistors can be removed if required.

Three-phase input power is fed to the bridge from the secondary of the PPT, either directly or through an ac breaker or disconnect, and a line-to-line filter. With inverting bridge designs, the bridge is capable of negative forcing voltage, which provides fast response for load rejection and de-excitation. The dc current output of the bridge is fed through a shunt, and on some designs a contactor (41A or both 41A and 41B) to the generator field. The bridge design utilizes dc leg fuses to protect the SCRs from overcurrent.

Current Shunt

EDCF provides dc current and voltage feedback

A dc shunt provides the bridge output current feedback signal. The mV output signal is input to a differential amplifier on the EDCF board. The amplifier output voltage controls the frequency of an oscillator, which generates a fiber-optic signal sent to the control module. The bridge output voltage feedback signal is generated in a similar way.

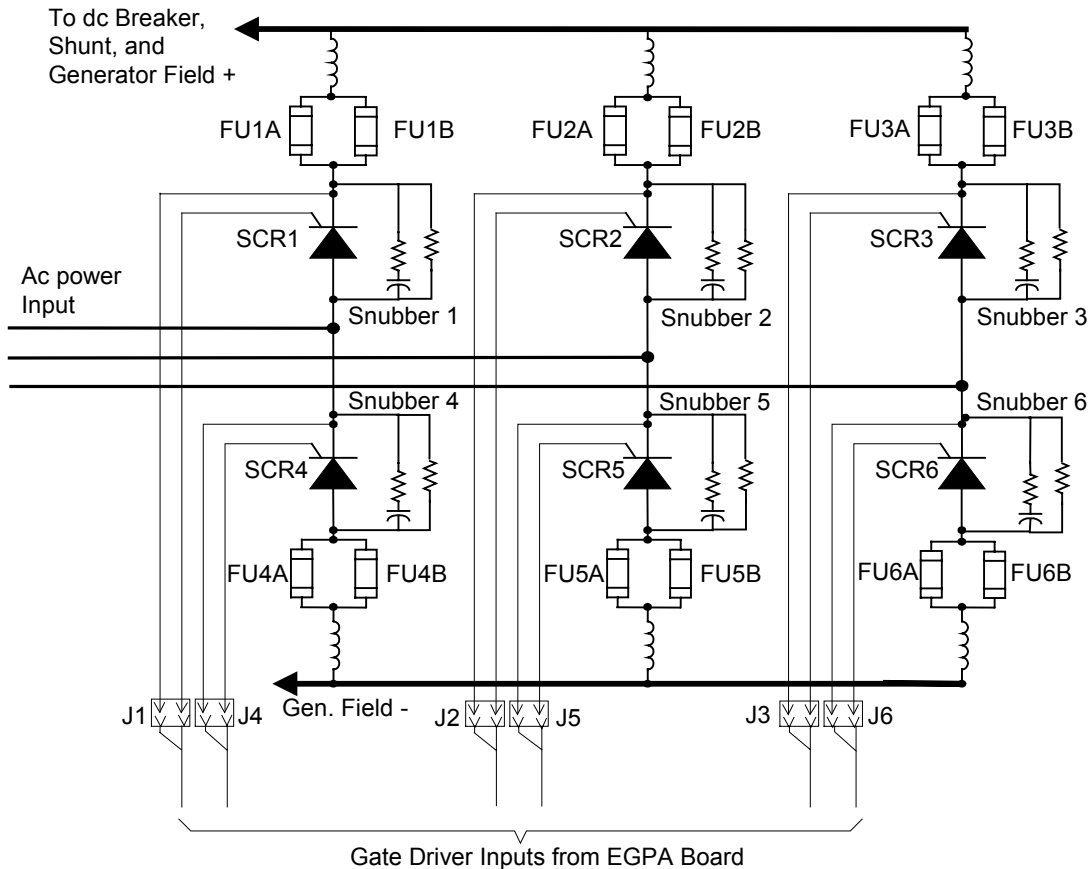

Figure 2-3. Power Bridge

Gate Pulse Amplifiers (EGPA Board)

The gate pulse amplifiers directly control the SCRs.

The EGPA board interfaces the control to the Power Bridge. EGPA takes the gate commands from the ESEL board in the controller, and generates the gate firing pulses for six SCRs (Silicon Controlled Rectifiers). It is also the interface for current conduction feedback, and bridge airflow and temperature monitoring.

On a new exciter, an RTD is used to monitor the temperature and generate alarms instead of the Klaxon switches. Additional switches actuated by fan rotation monitor cooling air flow across the bridge. On an exciter controls only retrofit, the exciter may have provisions for accepting feedback from two thermal switches mounted on the SCR heatsink assemblies. One thermal switch opens at the alarm level (170 °F (76 °C)) and the other at the trip level (190 °F (87 °C)). These switches are wired to the EGPA board and may require retrofitting into the existing bridge. If either switch opens, a bridge overtemperature alarm is generated. If both switches open, a fault and a trip are generated.

Cooling Fan Assembly

The SCR bridge assembly is cooled with forced air. From two to six overhead fans are used, depending on the bridge rating and redundancy requirements. The fans are powered by single-phase 115 V ac supplied by the customer. In redundant applications, a fan may be replaced while the exciter is running.

Main Dc Contactors. 41A or 41A/41B (Optional)

The main dc contactor (at the output of the power conversion module) provides a disconnect between the power conversion module and the generator field. The contactor picks up when the running mode is selected and no fault exists in the excitation. The contactors are normally actuated using pilot relays on the EXTB board driven by the controller. The auxiliary contacts from the contactor are routed back through the EXTB board as feedback signals.

Free Wheeling Diode De-excitation

De-excitation, the dissipation of the field current after the dc contactor opens, can be done with a free wheeling diode. This diode is connected from the generator field negative lead (anode) to the positive lead (cathode). The reverse voltage causes current to flow through the diode, and the field resistance causes the current decay.

Auxiliary Cabinet

The auxiliary cabinet is located next to the power conversion cabinet and contains modules to protect the generator and provide startup dc power. Modules for filtering the incoming ac power, for de-excitation, shaft voltage suppression, and field flashing are mounted in this cabinet.

Ac Line-to-Line Filters

Fuse protected line-to-line series RC filter circuits (snubbers) are provided to damp the ac system to prevent voltage spikes at the completion of SCR commutation. There are two styles of filters employed depending on the voltage. The 600 V filter uses RC circuits and MOVs. The 1000 V filter uses the 600 V version with additional RC circuits. Refer to Chapter 4 for details and connections.

De-excitation Module (EDEX)

During any shutdown, the energy stored in the generator field must be dissipated. In a *normal* shutdown, a stop is initiated by an operator. The bridge is fired at retard limit and sufficient time is allowed for the field to decay before the field contactors are opened. During an *abort* stop (trip), the field contactors are opened immediately. The stored field energy must be dissipated through some other means.

SCR De-excitation Module (EDEX)

For customers requiring a rapid de-excitation, an SCR de-excitation module is provided. In the EDEX module, an SCR is fired to provide a conduction path through the field discharge resistor (or inductor) for the field current to flow and dissipate the field energy.

The de-excitation module has dual independent firing control circuits. Each is activated by a parallel combination of auxiliary contacts representing the status of the field contactor(s), bridge ac supply breaker, and exciter bridge operating state. Any one of these paths can gate the de-excitation SCR which does not conduct unless the field voltage is inverted. If neither firing control circuit can fire the SCR, it is fired on overvoltage when the anode to gate voltage on the SCR exceeds the break over voltage of the breakover diode string connected between the anode and gate. De-excitation modules can be paralleled for larger excitation systems.

Thyrite

In systems that do not use the standard de-excitation module, a thyrite is connected across the dc output buses of the thyristor bridge. This protects the thyristors from high peak inverse voltages, which may occur as a result of abnormal generator operation. These are typically only supplied on salient pole generators.

Shaft Voltage Suppressor

The Shaft Voltage Suppressor protects the shaft bearings.

Excitation systems, which produce a dc voltage from ac through a solid state rectification process, produce ripple and spike voltages at the exciter output. Due to their rapid rise and decay times, these voltages are capacitively coupled from the field winding to the rotor body. This creates a voltage on the shaft relative to ground. Shaft voltage, if not effectively controlled, can be damaging to both journals and bearings. The shaft voltage suppressor is a filter that conducts the high frequency components of the induced voltages to ground. (This filter is shipped loose in some cases, otherwise it is part of the lineup).

Field Flashing Module

The field flashing module is provided on generator terminal fed excitation systems. It supplies initial exciter current and builds generator voltage, supplying approximately 10% - 15% of no-load field current from the station batteries during the startup sequence. If large machines require ac field flashing, the ac power is supplied through an isolation transformer. Both designs require customer supplied power.

Field Ground Detector (EXAM and EGDM)

The field ground detector protects the generator shaft.

The generator field winding is electrically isolated from ground. The existence of one ground usually does not damage the rotor. However, the presence of two or more grounds in the field winding path causes magnetic and thermal imbalances and localized heating, which may damage the rotor forging or other metallic parts.

The function of the field ground detector is to detect a ground path from any exciter component connected to and including the main field windings.

The Exciter Attenuator Module (EXAM) drives the electrical center of the field winding with a low frequency ac voltage relative to ground. To detect the current flow, the voltage across a sensing resistor is picked up by EXAM and measured by the EGDM module. This signal is sent over a fiber-optic link to the controller where it is monitored and alarmed. The EGDM boards (1 for simplex and 3 for redundant) are mounted in the control power supply module located in the control cabinet.

High Voltage Interface – HVI

The HVI contains the ac and dc bus, plus the line filter fuses. It also contains two terminal boards providing bridge feedback to the control and the EXAM board. The EACF board accepts incoming PPT ac voltage and air core CT current signals. It has transformers to isolate the voltages and produce low level signals. The EDCF board measures the bridge dc current and voltage, and sends it over fiber-optics to the control.

Control Cabinet

The control cabinet contains the keypad control rack, control power distribution module and supplies, and I/O terminal boards.

Diagnostic Interface (Keypad)

A second keypad is provided for redundant controls.

The keypad is a local operator interface that is mounted on the control cabinet door. Refer to Figure 2-4 for a view of the keypad and a summary of the operator and maintenance functions available. Chapter 5 describes the keypad in detail.

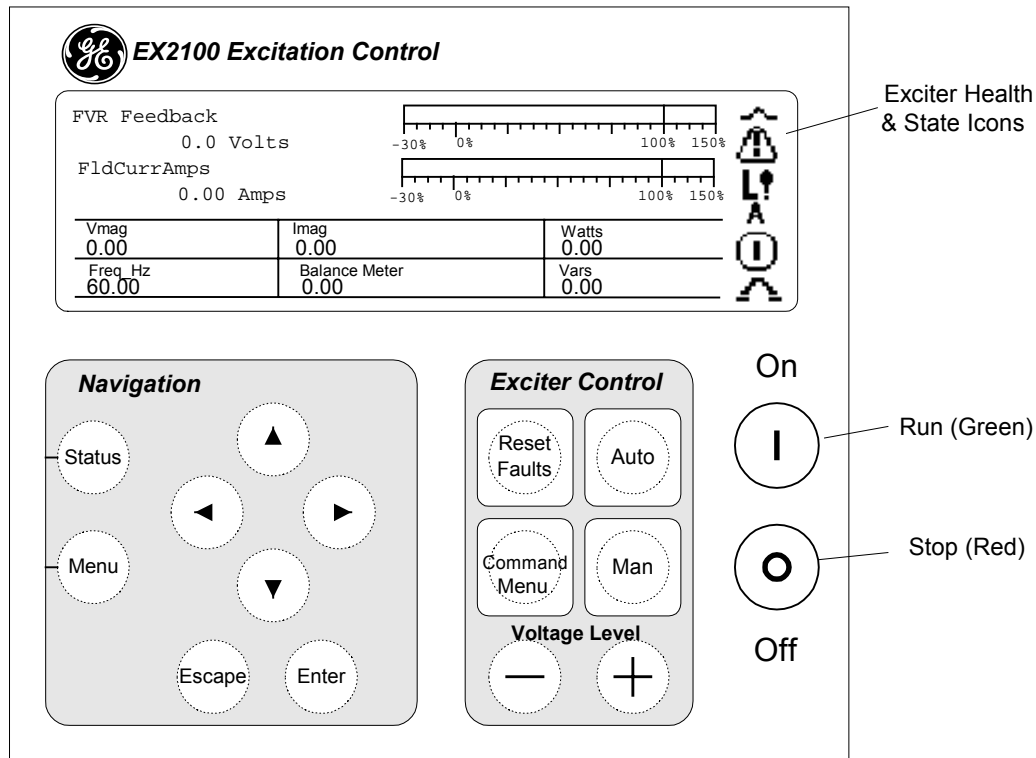

Display:

Status screens provide analog and digital representation of exciter functions and values.

Menu screens provide text-based access to parameters, wizards, and faults.

Pushbuttons:

Organized into functional groups:

Navigation buttons for using the menu

Exciter Control buttons

Run and Stop buttons

Figure 2-4. Diagnostic Interface – Keypad

Start/stop commands, regulator transfer commands, and regulator activation commands can be issued from the keypad. The keypad also includes meter displays indicating system conditions such as generator MW and MVARs, field current and voltage, and regulator balance. Diagnostic displays such as the alarm history display provide system information for maintenance and troubleshooting.

Control Module

The control module is a VME-style rack with boards cable connected to the I/O terminal boards. This rack is divided into three independently powered sections for the M1, M2, and C controllers. Each controller consists of control and I/O processor boards. If the rack contains only the M1 controller then it is a simplex control system; if the rack contains all three controllers then it is a redundant control system.

The control and I/O processor boards are as follows:

- Microprocessor-based Application Control Layer Module (ACLA) controller, with LAN Ethernet port
- Microprocessor-based Digital Signal Processor (DSPX) controller
- Exciter ISBus Board (EISB), with fiber-optic communication with the bridge feedback board
- Exciter Main I/O Board (EMIO), with control of pilot relays and gating commands to the ESEL board
- Exciter Selector Board (ESEL), with gate pulse distribution from the active controller to the EGPA.

Simplex Control System

The interconnections between the simplex control and the terminal boards, generator protection modules, and power supply are shown in Figure 2-5. Only one EPSM power supply is used but this can have both ac and dc supplies for increased reliability.

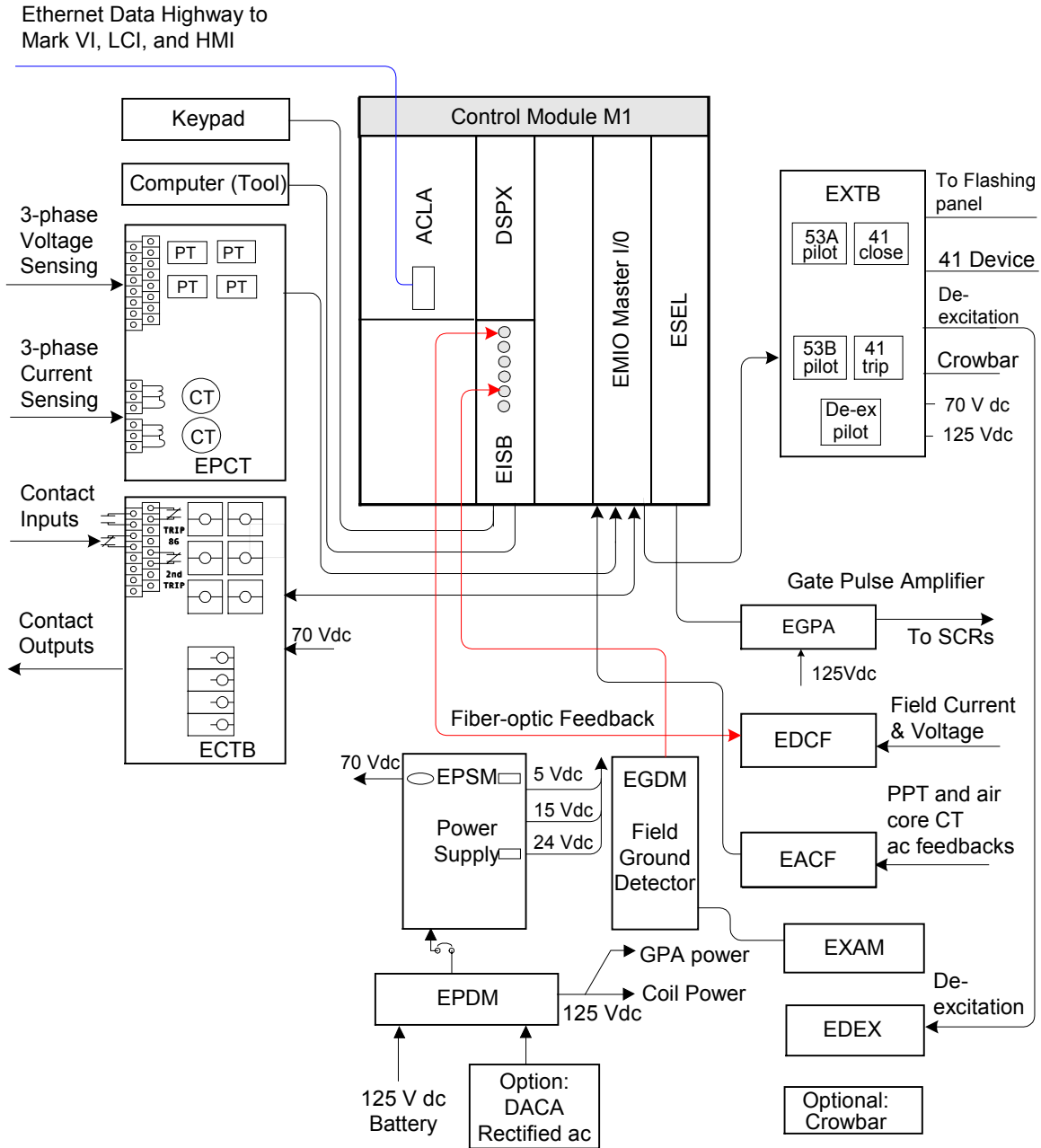

Figure 2-5. Simplex Control and Cabling to Terminal Boards

Redundant Control System

A redundant control system has three controllers and three redundant power supplies, one for each controller. The power supply rack also holds three ground detector modules. Figure 2-6 shows three EDCF boards, and there can be three EPCT boards, if required.

Up to two Ethernet cables are connected to the ACLA controllers (one to M1 and one to M2) for redundant communication with the turbine control and HMIs. Two keypads are shown connected to M1 and M2. Both keypads have access to the information in controller C.

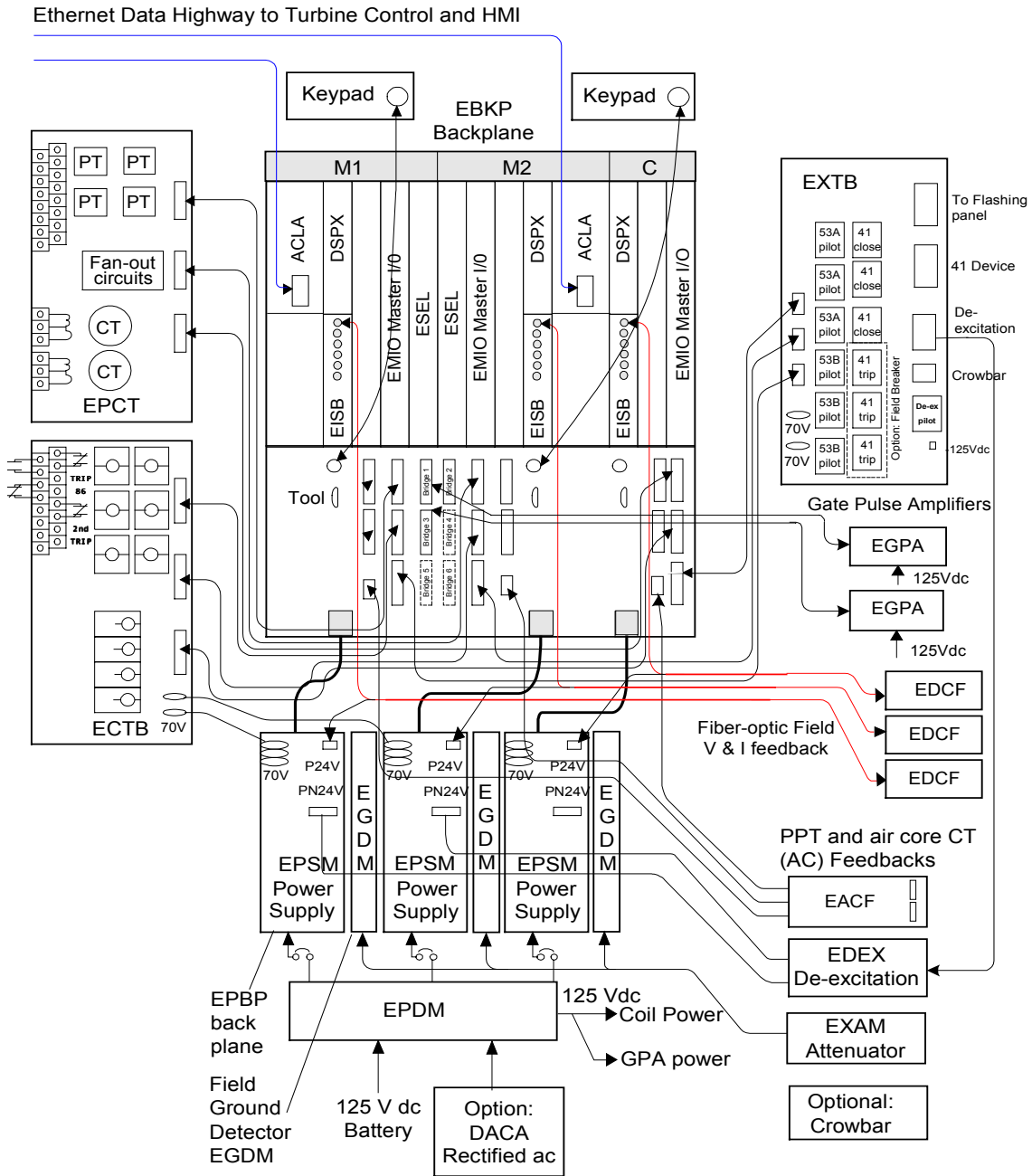

Figure 2-6. Redundant Control System Cabling

addition there is an isolated 70 V dc output for use by EXTB and ECTB for *contact wetting*.

Up to three ground detection modules (EGDM) are also mounted in the EPBP, as shown in Figure 2-9. These communicate with the EXAM module, which is located in the auxiliary cabinet.

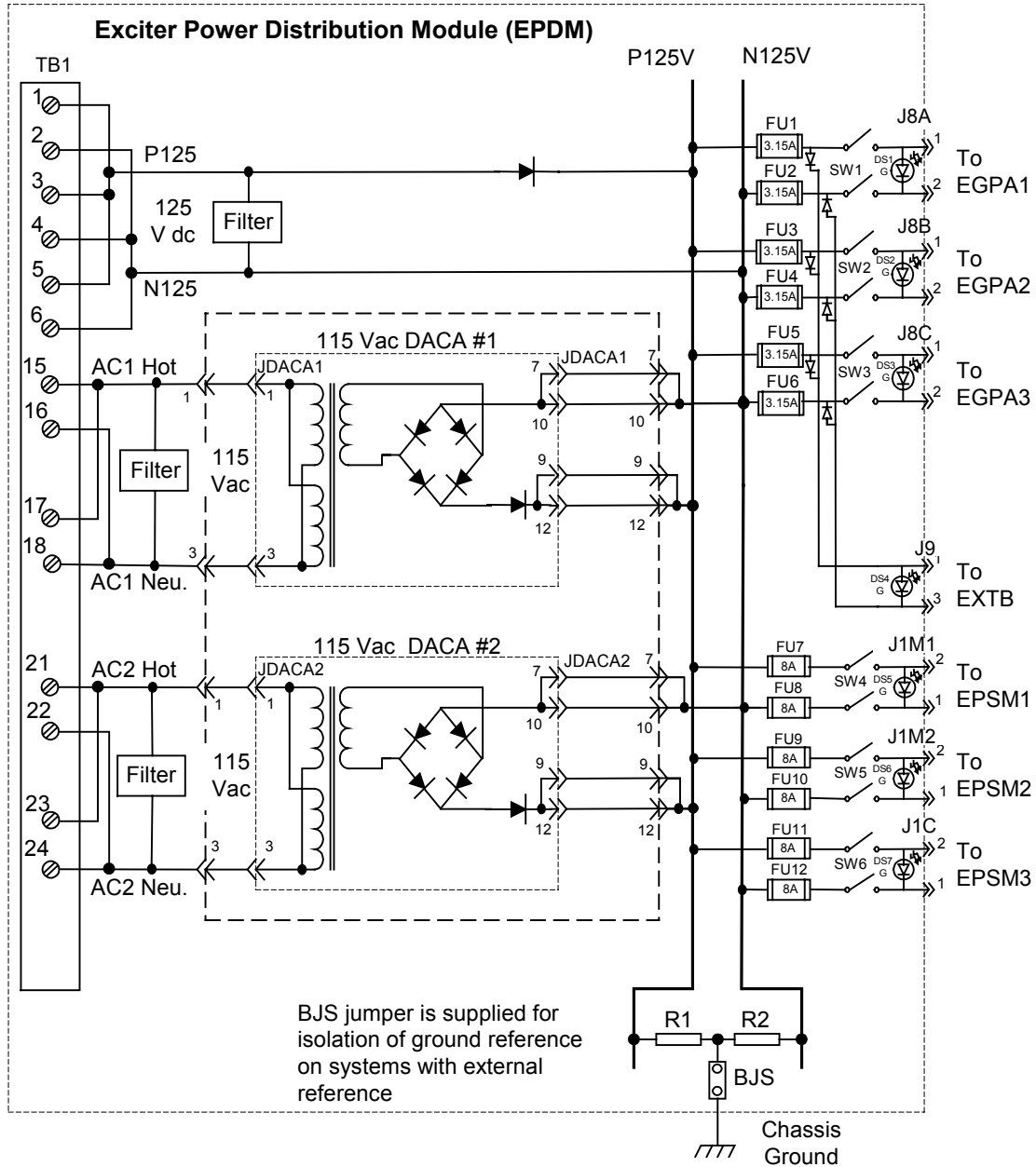

Figure 2-8. Exciter Power Distribution Module

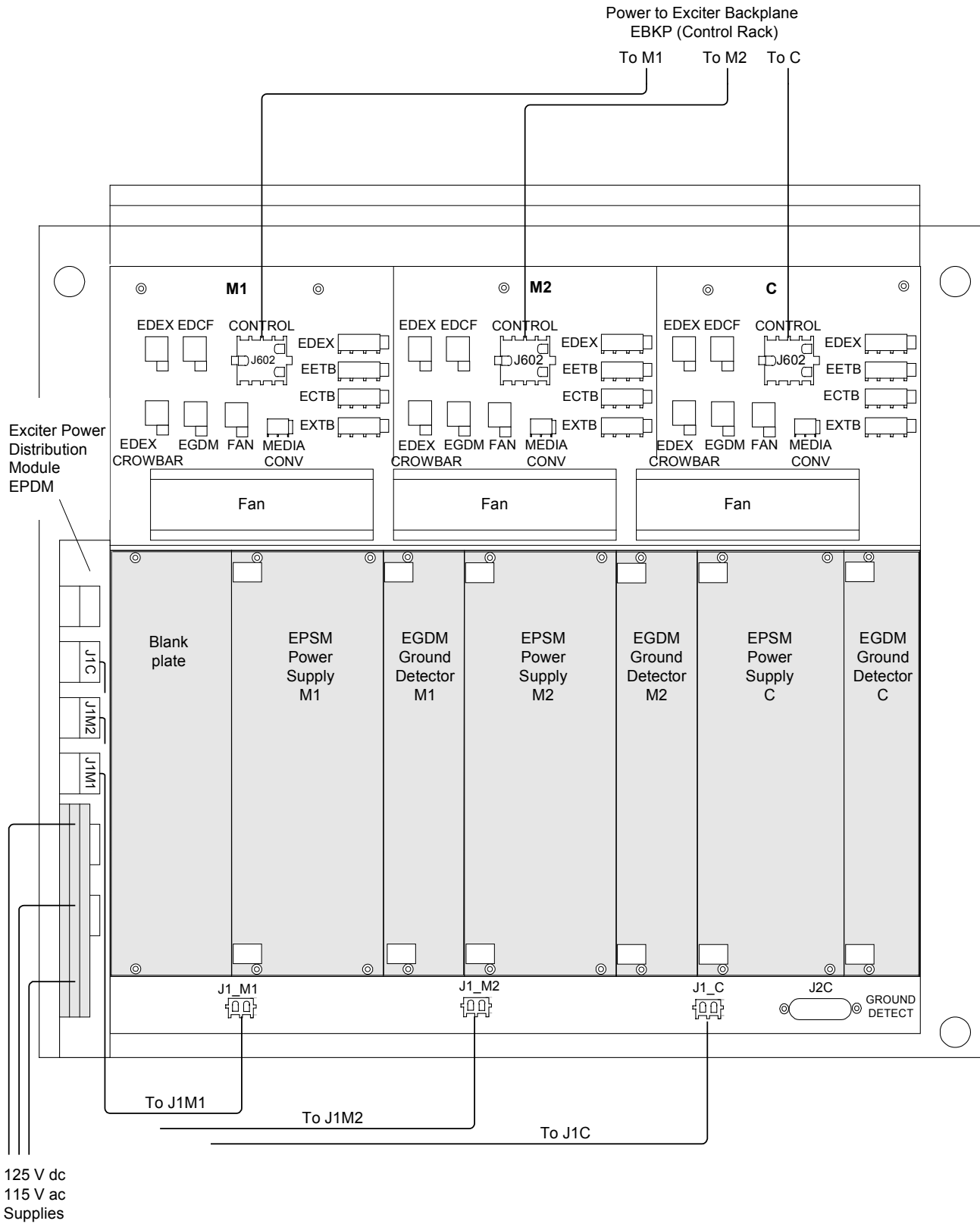

Figure 2-9. Exciter Power Backplane (EPBP) with EPDM, Power Supplies & Ground Detector Modules

Exciter Software

The exciter software is configured and loaded from the toolbox, and resides in the controllers. The software is represented on the toolbox screen by control blocks linked together to show the signal flow. Figure 2-10 is a simplified overview of the exciter control system displaying the main control functions. Both the generator field and stator currents and voltages are measured and input to the control system. In normal operation the ac regulator is selected. Figure 2-11 is the simplified software block diagram displaying the main control blocks.

The generator voltages and currents from the PTs and CTs are wired to the EPCT board, which acts as a signal conditioner to isolate and scale the signals. The conditioned signals are then fed to the controller. Software conversion algorithms use these signals to calculate system variables for use by the regulator, limiter, and protection functions. The outputs from these software calculations include the following:

- Generator voltage magnitude and generator frequency derived from the PTs
- The magnitude of generator current derived from the CTs
- Generator power, P
- Generator reactive volt amperes (VARs), Q
- Change in rotor speed calculated from the integral of accelerating power that is normally used as the input to the optional Power System Stabilizer (PSS)
- Generator active and reactive current
- Magnitude of generator flux (VHz)
- Line voltage derived from the PTs
- Line frequency derived from line PTs
- Phase angle correlation between the generator and line, derived from generator and line PTs

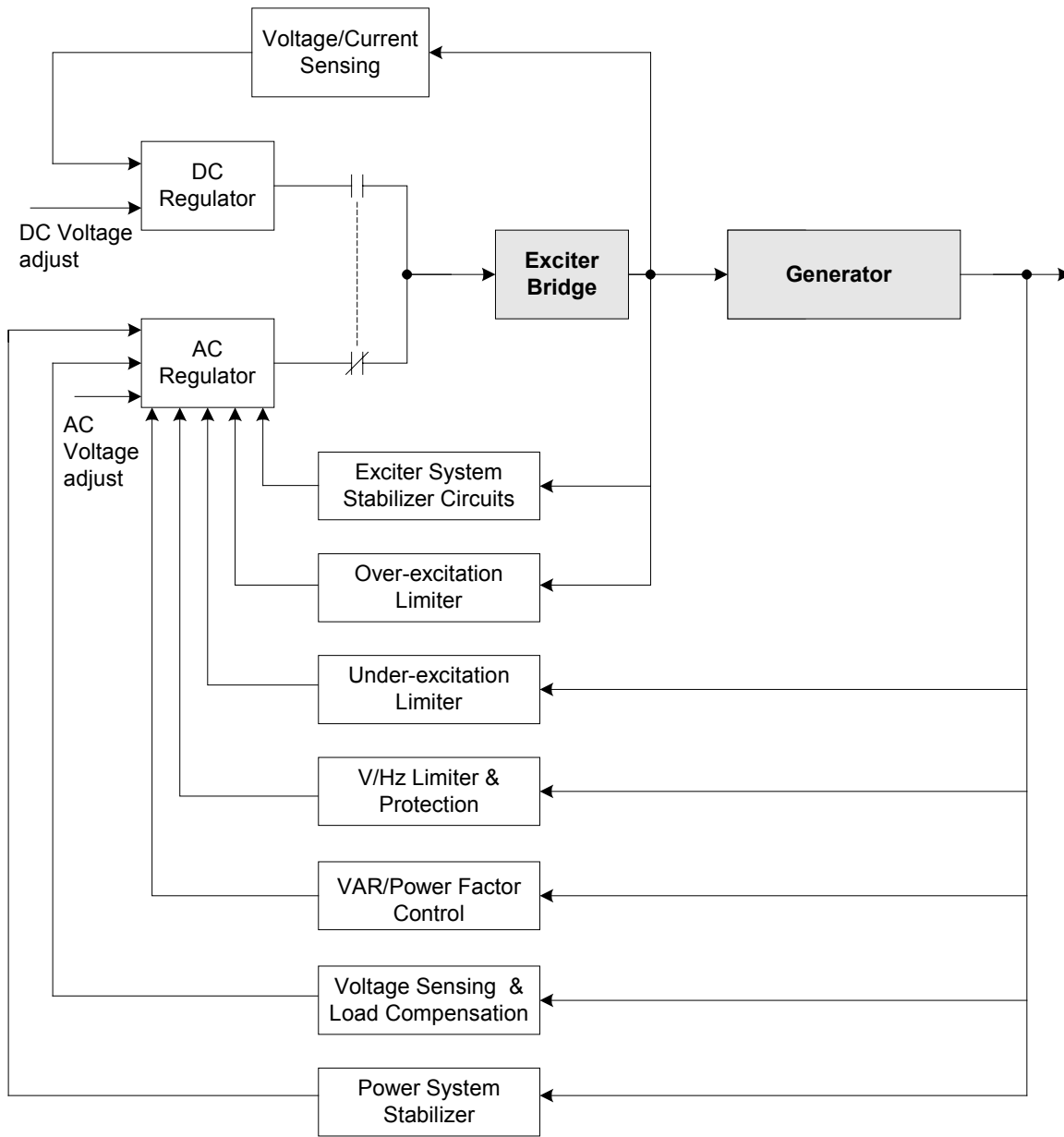

Figure 2-10. Control Scheme

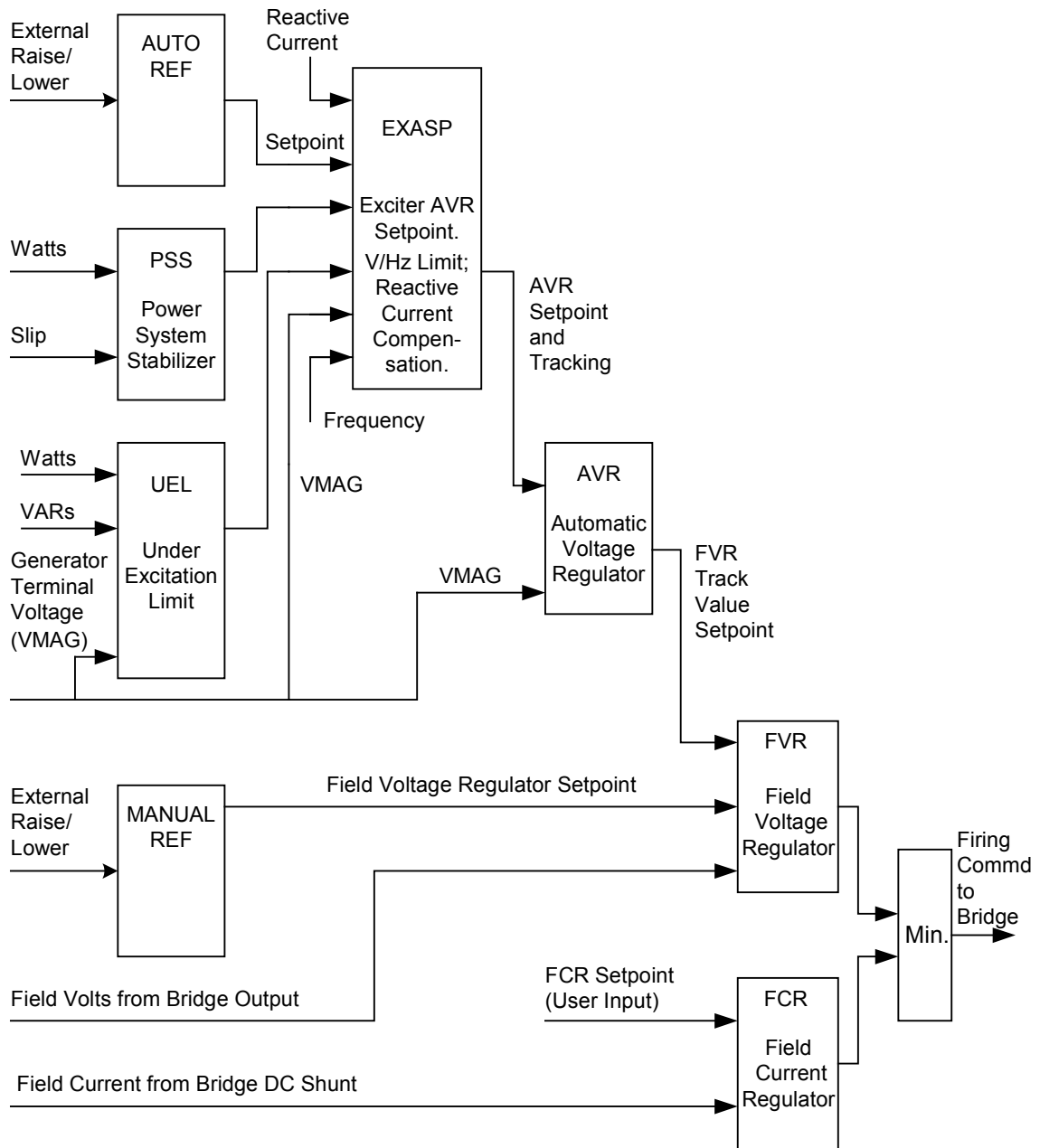

Figure 2-11. Software Block Diagram

The output of the control software is the firing command, which is sent to the bridge to generate the field current. The individual function blocks are discussed in the following sections.

Auto Reference – AUTO REF

The AUTOREF block generates an auto (or Auto Control (AC)) setpoint for the Automatic Voltage Regulator (AVR) based on user-supplied parameters and conditions. Raise/lower inputs to AUTO REF come in from the other devices on the Data Highway such as the turbine control or HMI. A variable rate integrator generates the output setpoint within preset limits. The setpoint is combined with other auxiliary stabilizing and protective signals in the EXASP block to form the reference to the AVR block.

AVR Setpoint – EXASP

The EXASP block combines a number of functions to produce the setpoint (reference input) to the AVR, and the AVR tracking value. The EXASP inputs are as follows:

- Stabilizing signal from the PSS block
- Output from the AUTOREF block
- External test signal
- Protective signal generated by the UEL block
- Reactive current input (feedback)
- Voltage magnitude input (feedback)
- Frequency input (feedback)

The outputs to the AVR block are the AVR setpoint and tracking value.

Automatic Voltage Regulator – AVR

The AVR block maintains the generator terminal voltage. The setpoint (reference) comes from the EXASP block, and the feedback is the generator voltage. The error value is input to a proportional plus integral (PI) regulator with integrator windup protection, which produces an output signal. Figure 2-12 shows the block diagram. When the AVR is enabled, the AVR output is passed through directly from the track input to the output of the Field Voltage Regulator (FVR).

Generator terminal voltage is controlled by the AVR.

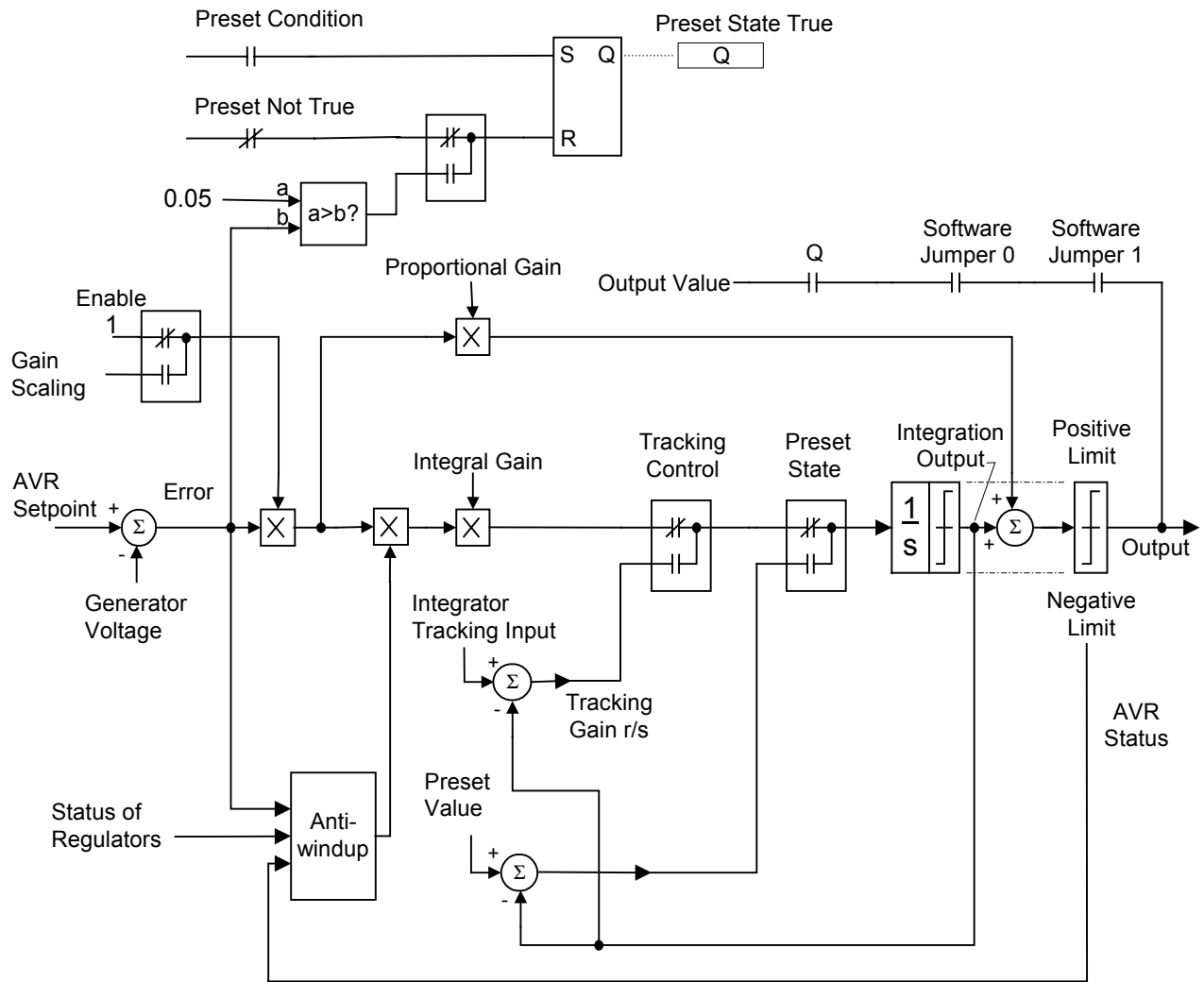

Figure 2-12. Automatic Voltage Regulator Block

Manual Reference – MANUAL REF

The MANUAL REF block generates a manual setpoint for the FVR or FCR based on user-supplied parameters and conditions. Raise/Lower inputs to MANUAL REF come in from other control devices on the Data Highway such as the turbine control or HMI.

Field Voltage and Current Regulators - FVR & FCR

The Field Voltage Regulator (FVR) is the typical manual regulator supplied on most applications and uses the generator field voltage as the feedback input. While FVR does permit the current to vary as a function of the field resistance, the FVR makes the manual regulator completely independent from the over excitation limiter. FVR uses the voltage from the generator field as feedback, with a setpoint from the MANUAL REF block. A PI regulator with integral windup protection generates the output. During operation in AVR mode, the output of the AVR is passed directly to the FVR output with no signal conditioning. On units that operate with an inner field

voltage regulator loop such as compound exciters and some high ceiling exciters, the FVR uses a setpoint from either the AVR or the MANUAL REF block, and is always operational whether in manual or automatic operation.

The Field Current Regulator (FCR) is a special application of the manual regulator and uses the generator field current as the feedback input. The current setpoint is generally switched between a high level and lower level to provide transient forcing capability as well as steady state operation within the capability of the generator. Generally the setpoint is larger than expected field currents and the integral preset is operational. The FCR output is held at positive ceiling until *enable* becomes true which allows the output to follow the P+I regulator. The bridge firing command is the smaller of the FVR and FCR outputs. While it does regulate constant field current over varying field temperature, FCR is not the standard manual regulator.

Under Excitation Limiter – UEL

The UEL block is an auxiliary control to limit the automatic voltage regulator demand for underexcited reactive current (or reactive power). UEL prevents reduction of the generator excitation to a level where the small-signal (steady state) stability limit, or the stator core end-region heating limit is exceeded. Performance is specified by identifying the region of limiter action on the generator capability curve. There is both a setpoint section and regulator section of the UEL. The two key inputs are generator terminal voltage and real power.

Power System Stabilizer – PSS

The PSS block provides an additional input to the automatic regulator to improve power system dynamic performance. A number of different quantities may be used as inputs to the PSS, such as shaft speed, frequency, synchronous machine electrical power, accelerating power, or some combination of the above. The PSS used with the exciter is multi-input using a combination of synchronous machine electrical power and internal frequency (which approximates rotor speed) to arrive at a signal proportional to rotor speed. This comes from the integral of accelerating power, but with shaft torsional signals greatly attenuated. The input signal is derived entirely from generator terminal quantities without the need for shaft speed transducers. No additional external hardware is required.

Operator Interface

The HMI contains exciter and turbine graphic displays.

Operator and engineering work stations such as the HMI (Human Machine Interface) and the toolbox communicate with the exciter. This allows operator monitoring and control of the exciter, and engineering access to system diagnostics and control block configuration

An HMI can be mounted in a control console or on a tabletop.

Turbine Control HMI

On turbine generator sets that include Mark VI turbine controls, the exciter shares the HMI. The HMI is Windows NT[®] based with CIMPLICITY operator display software and communication drivers for the data highways. From the HMI, the operator can initiate commands and view real-time data and alarms on the CIMPLICITY graphic displays. An HMI can be configured as a server or viewer, and can contain tools and utility programs.

Redundant cable operation is optional and, if supplied, operation continues even if one cable is faulted.

The Unit Data Highway (UDH) connects the exciter with the HMI or HMI/Data Server. The network is 10BaseT Ethernet, and uses separately powered network switches. For longer runs, fiber-optic cables can be used.

Control System Toolbox (toolbox)

The toolbox is used to configure and maintain the exciter. Control blocks and diagrams can be modified by configuration and loaded into the control. With the exciter online, real-time data is available on the toolbox screen, including control system diagnostics for troubleshooting. The toolbox software runs on an HMI server or a separate PC on the UDH. Direct connection to the controller DSPX board is also possible through the Tool port on the control rack backplane.

Notes

Chapter 3 Printed Wiring Boards Overview

Introduction

This chapter describes the EX2100 printed wiring boards and their operation. These boards fall into four functional groups; control rack boards including controller boards and I/O processors, I/O terminal boards, bridge control and protection modules, and power supply boards. This chapter is organized as follows:

Section	Page
Control Boards.....	3-2
EBKP Backplane.....	3-2
DSPX Board.....	3-2
ACLA Board.....	3-4
EISB Board.....	3-4
EMIO Board.....	3-4
ESEL Board.....	3-4
I/O Terminal Boards.....	3-5
EPCT Board.....	3-5
ECTB Board.....	3-5
EXTB Board.....	3-5
EDCF Board.....	3-6
EACF Board.....	3-6
Bridge and Protection Boards and Modules.....	3-7
EGPA Board.....	3-7
EXCS Board.....	3-7
EDEX Board.....	3-7
EGDM Module.....	3-7
EXAM Module.....	3-8
Power Supply Boards.....	3-9
EPDM Module.....	3-9
EPBP Backplane.....	3-9
EPSM Module.....	3-9
DACA – Ac to Dc Converter.....	3-10
Related Board Publications.....	3-11

Control Boards

The control boards are located in the control module. This module consists of the exciter backplane (EBKP) and the metal chassis that holds the boards (refer to Figure 3-1). The control boards are as follows:

- IS200DSPX Digital Signal Processor control board (DSPX)
- IS215ACLA Application Control Layer Module (ACLA)
- IS200EISB Exciter ISBus Board (EISB)
- IS200EMIO Exciter Main I/O board (EMIO)
- IS200ESEL Exciter Selector board (ESEL)

EBKP Backplane

The EBKP provides the backplane for the control boards and the connectors for the I/O terminal board cables. EBKP has three sections for controllers M1, M2, and C. Each section has its own independent power supply. Controllers M1 and M2 have the ACLA, DSPX, EISB, EMIO, and ESEL boards. Section C only has the DSPX, EISB, and EMIO. Two overhead fans cool the controllers.

The upper part of the backplane contains DIN connectors for the plug-in control boards. The lower part of the backplane contains D-SUB connectors for I/O interface cables, and circular DIN connectors for keypad interface cables, power supply plugs, and test rings. Labels on the connectors in Figure 3-1 refer to the boards and devices to which the cables are connected. For more information refer to Chapter 4 and GEI-100460.

DSPX Board

The DSPX board is the main controller and shares control responsibility with the ACLA. It is a single-slot, 3U high module located in the control rack next to the ACLA. It provides functions including the bridge firing circuit control, I/O processing, and inner loop regulation as follows:

- Field Voltage Regulator (FVR)
- Field Current Regulator (FCR)
- SCR gating signals to the ESEL board
- Start-stop function
- Field flashing control
- Alarms and trip logic
- Generator instrumentation processing
- Generator simulator

For more information refer to Chapter 4 and GEI-100267.

The DSPX performs most of the I/O interface and inner loop bridge control and protection functions

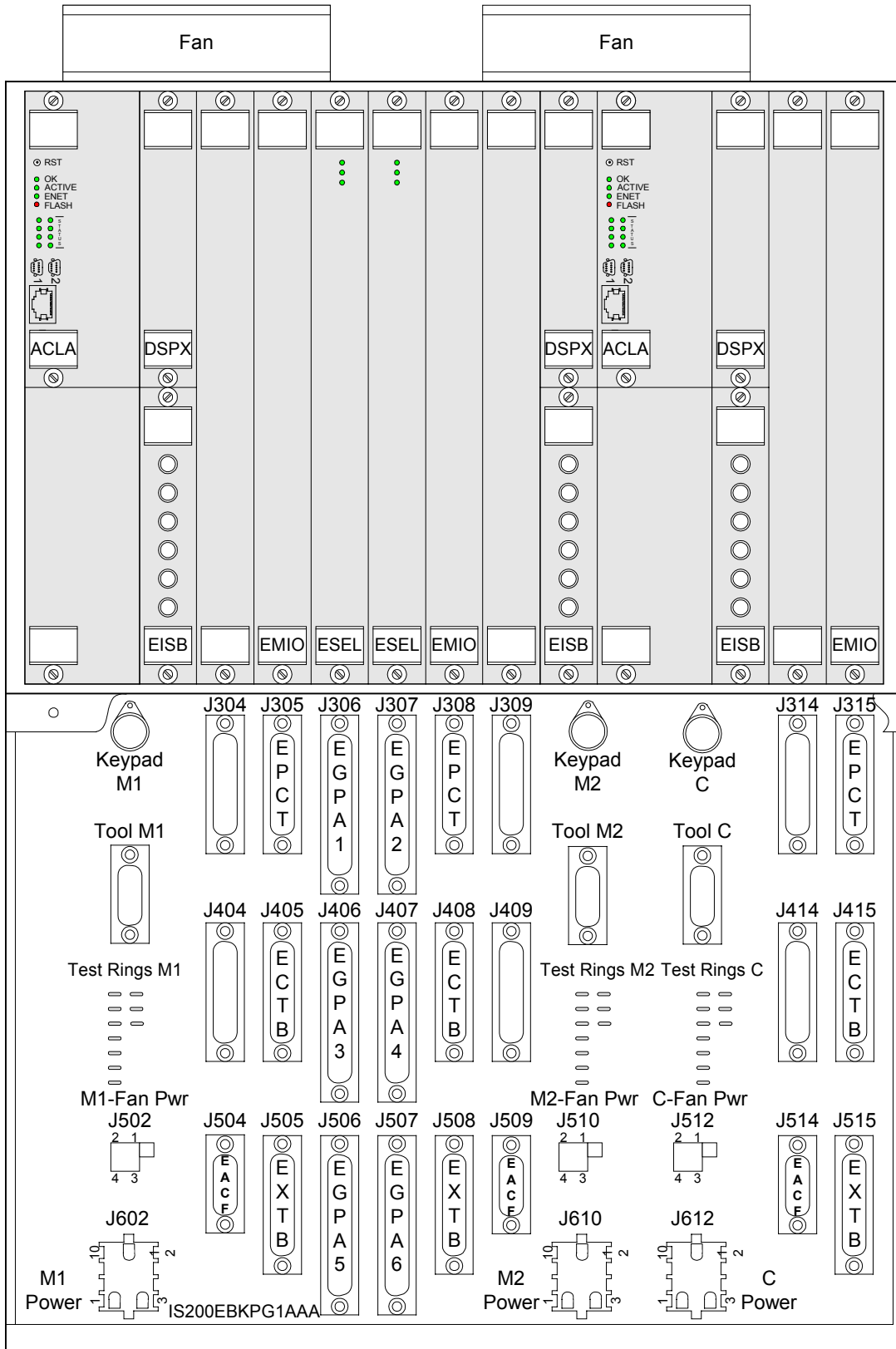

Figure 3-1. Control Module

ACLA handles network communications and outer loop functions.

ACLA Board

The ACLA board is a double-slot, 3U high module located next to the DSPX. ACLA provides Ethernet communications with the turbine control, LCI, and HMI, and runs outer loop control functions including the following:

- Automatic Voltage Regulator (AVR)
- Power System Stabilizer (PSS)
- Under Excitation Limit control (UEL)
- VAR/power factor regulator (VAR/PF)

For more information refer to Chapter 4 and GEI-100434.

EISB Board

EISB manages all the fiber-optic communication in the cabinets.

The Exciter ISBus Board (EISB) is a special communication interface board for the M1, M2, and C control modules. ISBus is a proprietary, high-speed communication bus used in many GE systems. The EISB is used to provide communication among the 3 DSPSs in M1, M2, and C. EISB receives and transmits fiber-optic feedback signals through the backplane connector. It transmits them over the control backplane to the DSPX controller and also communicates between the DSPX and the tool and keypad ports using RS-232C. EISB is a single-slot, 3U high module that is located in the control rack under the DSPX. From six fiber-optic connectors on the front panel it accepts current and voltage signals from the generator field (and from the exciter if required) using EDCF boards, and receives and transmits signals to the Ground Detection Module (EGDM). For more information refer to Chapter 4 and GEI-100454.

EMIO Board

The EMIO is a single slot, double height VME style board, that manages the I/O from the EPCT, ECTB, EACF, and EXTB terminal boards. The I/O include PT and CT signals, contact inputs, output relay drivers, and pilot trip relay drivers. It also sends logic level gate pulse signals over the backplane to the ESEL board, which sends them to EGPA in the power conversion cabinet. For more information refer to Chapter 4 and GEI-100453.

ESEL Board

The Exciter Selector board receives six logic level gate pulse signals from its corresponding EMIO. These pulse signals drive up to six sets of cables which are distributed to the exciter gate pulse amplifier (EGPA) boards. The EGPA boards are mounted in the power conversion cabinet. If there are redundant controls, two ESEL are used, one driven by M1 and the other by M2. The active ESEL, selected by controller C, sends the necessary control signals to the EGPA boards.

Three groups of ESEL boards are available supporting increasing redundancy levels; ESELH1 contains a single bridge driver, ESELH2 contains three bridge drivers, and ESELH3 contains six bridge drivers. For more information refer to Chapter 4 and GEI-100456.

I/O Terminal Boards

The exciter terminal boards are as follows:

- IS200EPCT Exciter PT/CT board (EPCT)
- IS200ECTB Exciter Contact Terminal Board (ECTB)
- IS200EXTB Exciter Terminal Board (EXTB)
- IS200EDCF Exciter Dc Feedback board (EDCF)
- IS200EACF Exciter Ac Feedback board (EACF)

EPCT Board

EPCT receives and conditions generator PT and CT feedbacks.

The EPCT contains isolation transformers for critical generator voltage and current measurements. Two three-phase generator PT voltage inputs are input to EPCT. Two generator CT current inputs, with current levels of 1 A or 5 A, are input. In addition, one analog input, which can be either 0-10 V or 4-20 mA, is brought into EPCT. All the signals are interfaced to the EMIO board. For more information refer to Chapter 4 and GEI-100459.

ECTB Board

The ECTB board supports excitation contact outputs and contact inputs. There are two versions; the ECTBG1 board which is only used in the redundant mode, and the ECTBG2 board which is only used in the simplex mode. Each board contains two trip contact outputs driving a customer lockout, and four general purpose Form-C relay contact outputs, controlled by the EMIO board. Six auxiliary contact inputs are powered (wetted) with 70 V dc by ECTB. Also, the 52G and 86 G contact inputs are powered and monitored by ECTB. In the redundant case, power comes from the M1 and M2 power supplies. For more information refer to Chapter 4 and GEI-100457.

EXTB Board

EXTB handles field flashing and protection functions.

The EXTB board supports pilot relay contact outputs, contact inputs, and signal conditioning circuits. EXTB cables to the EMIO board through the EBKP backplane.

Pilot relays for the breaker/contactors close 41, and flashing contactors 53A, and 53B are located on the board, plus pilot relays for the trip relay 41T and the de-excitation relay KDEP. Crowbar status signals and de-excitation status signals from the EDEX board are conditioned on EXTB and sent to EMIO. Three contact inputs from 41, 53A, and 53B are powered (wetted) by 70 V dc on EXTB. Power for the contacts is from the M1 and M2 power supplies (redundantly), and the resulting status signals are sent to EMIO in the control rack. Different groups of EXTB are available for controlling either a field breaker or a contactor in the field circuit. These groups are defined in Table 3-1. For more information refer to GEI-100458.

Table 3-1. EXTB Board Groups

Type of Redundancy	Board	Control Mode	Trip Relay 41T used	Close Relay 41 used
Redundant control	EXTB G1	Contactors Mode	No	Yes
Redundant control	EXTB G3	Breaker Mode	Yes	Yes
Simplex control	EXTB G2	Contactors Mode	No	Yes
Simplex control	EXTB G4	Breaker Mode	Yes	Yes

EDCF Board

EDCF handles bridge dc voltage and current feedback.

The EDCF board measures field current and field voltage at the SCR bridge, and interfaces to the EISB board in the control panel over a high-speed fiber-optic link. The fiber-optics provides voltage isolation between the two boards, and high noise immunity. Field current is measured using a shunt in the dc field circuit. The field voltage feedback circuit provides seven selector settings to scale down the bridge voltage, depending on the type of bridge application. For more information refer to Chapter 4 and GEI-100464.

EACF Board

EACF handles bridge ac voltage and current feedback.

The EACF board measures the exciter PPT ac supply voltage and current. The EACF terminal board contains transformers for a 3-phase voltage measurement, and terminals for two Flux/Air core coils. The outputs of the voltage and current circuits are fanned out to three DB9 connectors for cables to controllers M1, M2, and C. These cables can be up to 90 m in length. There are two versions of this board, EACFG1 is for inputs up to 480 V rms, and EACFG2 is for inputs up to 1000 V rms. For more information refer to Chapter 4 and GEI-100465.

Bridge and Protection Boards and Modules

The exciter bridge and protection boards are as follows:

- IS200EGPA Exciter Gate Pulse Amplifier board (EGPA)
- IS200EXCS Conduction Sensor board (EXCS)
- IS200EDEX Exciter De-Excitation board (EDEX)
- IS200EGDM Exciter Field Ground Detector Module (EGDM)
- IS200EXAM Exciter Attenuator Module (EXAM)
- Crowbar module

EGPA Board

Bridge control passes through EGPA. One EGPA is required per PCM.

The EGPA board interfaces the control to the power bridge. EGPA takes the six gate commands from the ESEL and controls the gate firing of up to six SCRs on the bridge. It is also the interface for current conduction feedback, and the bridge airflow and temperature monitoring.

A nominal 125 V dc power source from EPDM supplies an on-board dc/dc converter that provides power for SCR gating over the full range of input supply voltage. LEDs provide visual indication of the status of the output firing, currents into the bridge, gate power supply, line filter, cooling fan rotation, and bridge temperature and alarm or fault conditions. For more information refer to Chapter 4 and GEI-100461.

EXCS Board

The EXCS board has four conduction sensors. It is used to detect the presence of current in the bus. The output is a logic signal.

EDEX Board

EDEX is usually controlled by EXTB, but can initiate de-excitation if control fails.

The EDEX board is the main board in the de-excitation module. EDEX provides de-excitation SCR firing, conduction sense feedback, and voltage retention to ensure operation in the event of a power failure. EMIO initiates de-excitation on the EXTB board. The EXTB board opens the 41 dc contactor (41A/41B) or breaker, and then transfers de-excitation signals from the auxiliary contacts to SCR firing circuits on the EDEX. There are two types of EDEX. Group 1 board is designed for SCR de-excitation, Group 2 is designed for diode de-excitation. For more information refer to Chapter 4 and GEI-100466.

EGDM Module

EGDM and EXAM work together to detect field ground leakage current.

The EGDM is a double slot, double height (6U) form factor board that mounts in the Exciter Power Backplane rack (EPBP). A simplex system has one EGDM, while a redundant system has three. EGDM detects field leakage resistance from any point in the field circuit of the generator to ground, either on the ac or dc side. The field ground detector applies a low frequency square wave to the sense resistor connected to the field circuit. EXAM, the attenuator module located in the Auxiliary Panel, senses the voltage across the ground resistor and sends the signal to the EGDM through a nine-conductor cable.

In a redundant system, the set of three EGDM boards are configured as a Controller (C), Master 1 (M1) and Master 2 (M2). The configuration for each EGDM is controlled by a set of program pins on the P2 connector. The C controller receives information from the active DSPX on which EGDM master should provide the drive signal to the sense resistor in the Attenuator Module. The active master receives an *Oscillator Signal* over the fiber optic link that it converts to a ± 50 V signal. This is applied to one end of the sense resistor in the Attenuator Module.

The signal conditioner receives an attenuated (10:1) differential signal from the Sense Resistor. This is a simple unity gain differential amplifier with a high common-mode rejection ratio followed by an A-to-D converter (Voltage Controlled Oscillator VCO). This feeds a fiber-optic transmitter that is cabled to EISB. The signal conditioner circuitry is powered by an isolated power supply to maintain personnel and equipment safety due to the high common-mode voltage at the Sense Resistor. For more information refer to Chapter 4 and GEI-100467.

EXAM Module

The EXAM mounts in the auxiliary cabinet and contains a sense resistor connected to a resistor network across the field. EXAM applies the low frequency ± 50 V square-wave signal, supplied from the EGDM, to one end of the sense resistor. The resulting current generates a voltage across the resistor, that is sent back to the EGDM.

In a redundant system, the test signal can come from either, M1 or M2. EXAM has a relay that switches between the two under the control of controller C. A single cable carries the control and sense signals between the EGDM and EXAM modules. For more information refer to Chapter 4 and GEI-100467.

Power Supply Boards

The exciter power supply boards are as follows:

- IS200EPDM Exciter Power Distribution Module (EPDM)
- IS200EPBP Exciter Power Backplane (EPBP)
- IS200EPSM Exciter Power Supply Module (EPSM)
- DACA Module

EPDM Module

The EPDM provides the power for the control, I/O, and protection boards. It is mounted on the side of the EPBP and accepts a 125 V dc supply from the station battery, and one or two 115 V ac supplies. All supply inputs are filtered. Each ac supply is rectified to 125 V dc in an ac to dc converter (DACA). The resulting two or three dc voltages are diode coupled together to create the dc source supply, designated as P125V and N125V. With the center grounded, these voltages are nominally +62.5 V and -62.5 V to ground.

Any of the exciter power supply modules can be switched off from the EPDM.

Individual supply outputs to the exciter boards are fused. They have an on/off toggle switch, and a green LED indicator to display supply power availability. These outputs supply up to three EGPA boards, the EXTB board, and three EPSM modules serving the three controllers. Outputs are wired to the EPBP for distribution. For more information refer to Chapter 4.

EPBP Backplane

The EPBP holds three electrically isolated power supplies (EPSM) that supply power to the M1, M2, and C controllers. It also holds three EGDM. EPBP accepts 125 V dc from the adjacent EPDM, and distributes logic level power from the three EPSM to the three controllers. Each power supply has an independent ON-OFF switch on the EPDM. The EPSM modules interface to the backplane through DIN connectors. 70 V dc and 24 V dc power is distributed from the locking connectors at the top of the backplane to the terminal boards. Refer to Figure 3-2. For more information refer to Chapter 4 and GEI-100463.

EPSM Module

The EPSM converts 125 V dc from the EPDM into the voltages required for the control system. There are three independent power supplies that supply power to each of the controllers M1, M2, and C. These supplies are located in the power supply module mounted below the control rack in the control cabinet.

The EPSM supplies +5 V dc, ± 15 V dc, and +24 V dc to the controller. Power is also supplied to modules external to the control rack as follows:

- ± 24 V dc to power the EDEX de-excitation module, crowbar module, EGDM, and EDCF
- Isolated +70 V dc for *contact wetting* to the EXTB and ECTB boards

For more information refer to Chapter 4 and GEI-100462.

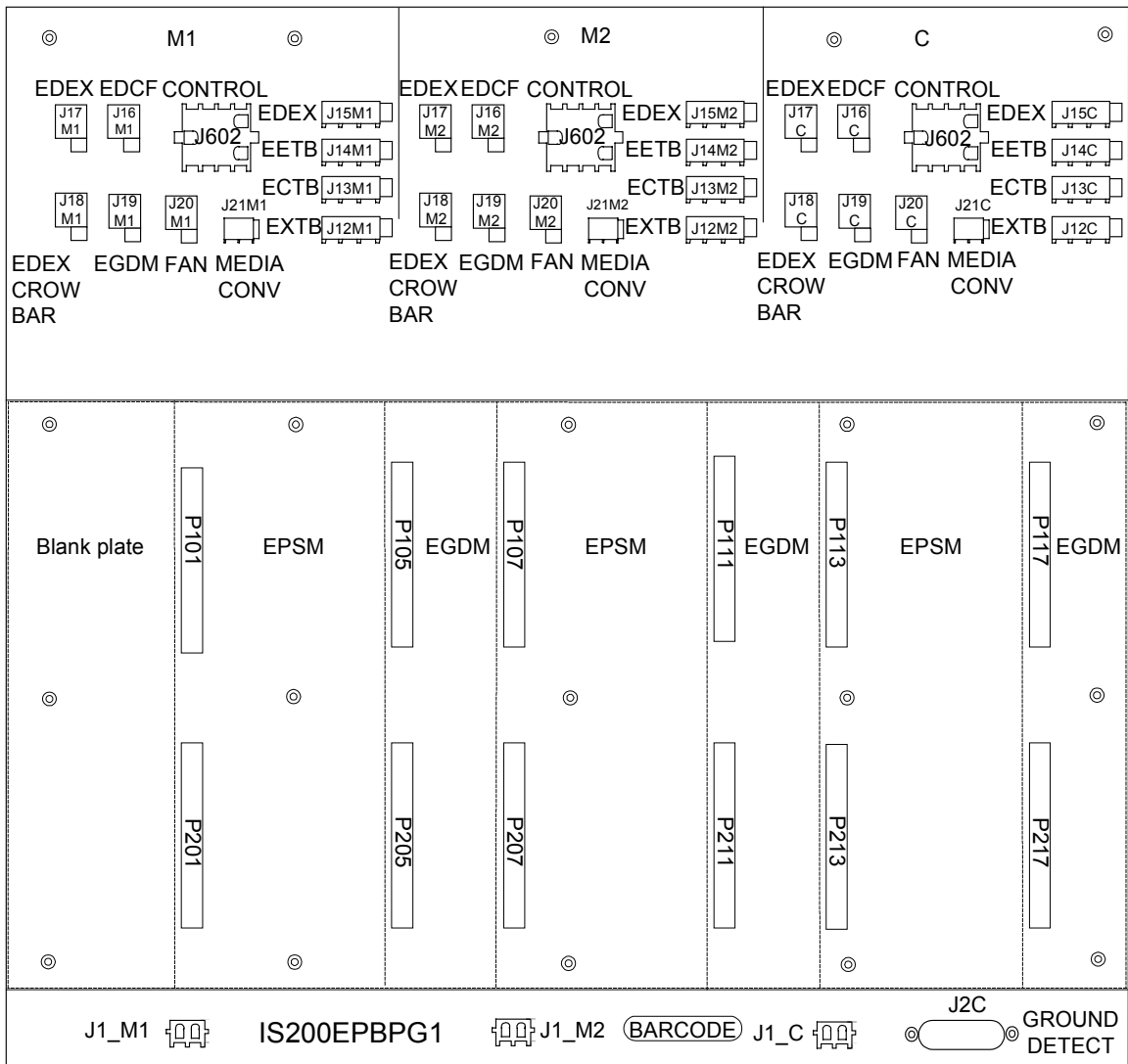

Figure 3-2. Exciter Power Backplane

DACA – Ac to Dc Converter

The DACA is an ac to dc converter that is powered by a 115 V ac source and produces 125 V dc. The DACA and battery source provide a redundant 125 V dc supply for the EPDM. Two DACAs can be connected to the EPDM if required for greater power supply reliability.

Related Board Publications

For a more detailed description of each board's circuitry and application data, refer to the following documents:

- GEI-100460 IS200EBKP Exciter Backplane
- GEI-100267 IS200DSPX Digital Signal Processor Board
- GEI-100434 IS215ACLAH1 Application Control Layer Board
- GEI-100454 IS200EISB Exciter ISBus board
- GEI-100453 IS200EMIO Exciter Main I/O board
- GEI-100456 IS200ESEL Exciter Selector board
- GEI-100459 IS200EPCT Exciter PT/CT board
- GEI-100457 IS200ECTB Exciter Contact Terminal Board
- GEI-100458 IS200EXTB Exciter Terminal Board
- GEI-100464 IS200EDCF Exciter DC Feedback board
- GEI-100465 IS200EACF Exciter AC Feedback board
- GEI-100461 IS200EGPA Exciter Gate Pulse Amplifier board
- GEI-100466 IS200EDEX Exciter De-Excitation board
- GEI-100467 IS200EGDM Exciter Ground Detector Module
- GEI-100463 IS200EPBP Exciter Power Backplane
- GEI-100462 IS200EPSM Exciter Power Supply Module

Notes

Chapter 4 Terminal Board I/O and Equipment Connections

Introduction

This chapter describes the customer's equipment connections, and inputs and outputs (I/O) available through terminal board wiring. System cabling to provide desired functionality is also defined. The information is organized as follows:

Section	Page
Power Connections and Analog I/O.....	4-2
Power Potential Transformer Inputs.....	4-3
Potential and Current Transformer Inputs.....	4-3
Analog Input.....	4-3
Customer Contact I/O.....	4-4
Power Supply Inputs.....	4-6
Line Filter Connections.....	4-7
Exciter Internal I/O.....	4-8
Exciter AC Feedback.....	4-8
Exciter DC Feedback.....	4-8
De-Excitation.....	4-11
Crowbar.....	4-14
Field Ground Detector.....	4-14
Field Flashing.....	4-16
Dc Field Flashing Settings.....	4-16
Flashing Control Sequence.....	4-16
Shaft Voltage Suppressor.....	4-18
Data Highway Connections.....	4-19
Control System Toolbox Connection.....	4-20

Power Connections and Analog I/O

Figure 4-1 displays a typical connection diagram of the common power and analog I/O for an excitation system.

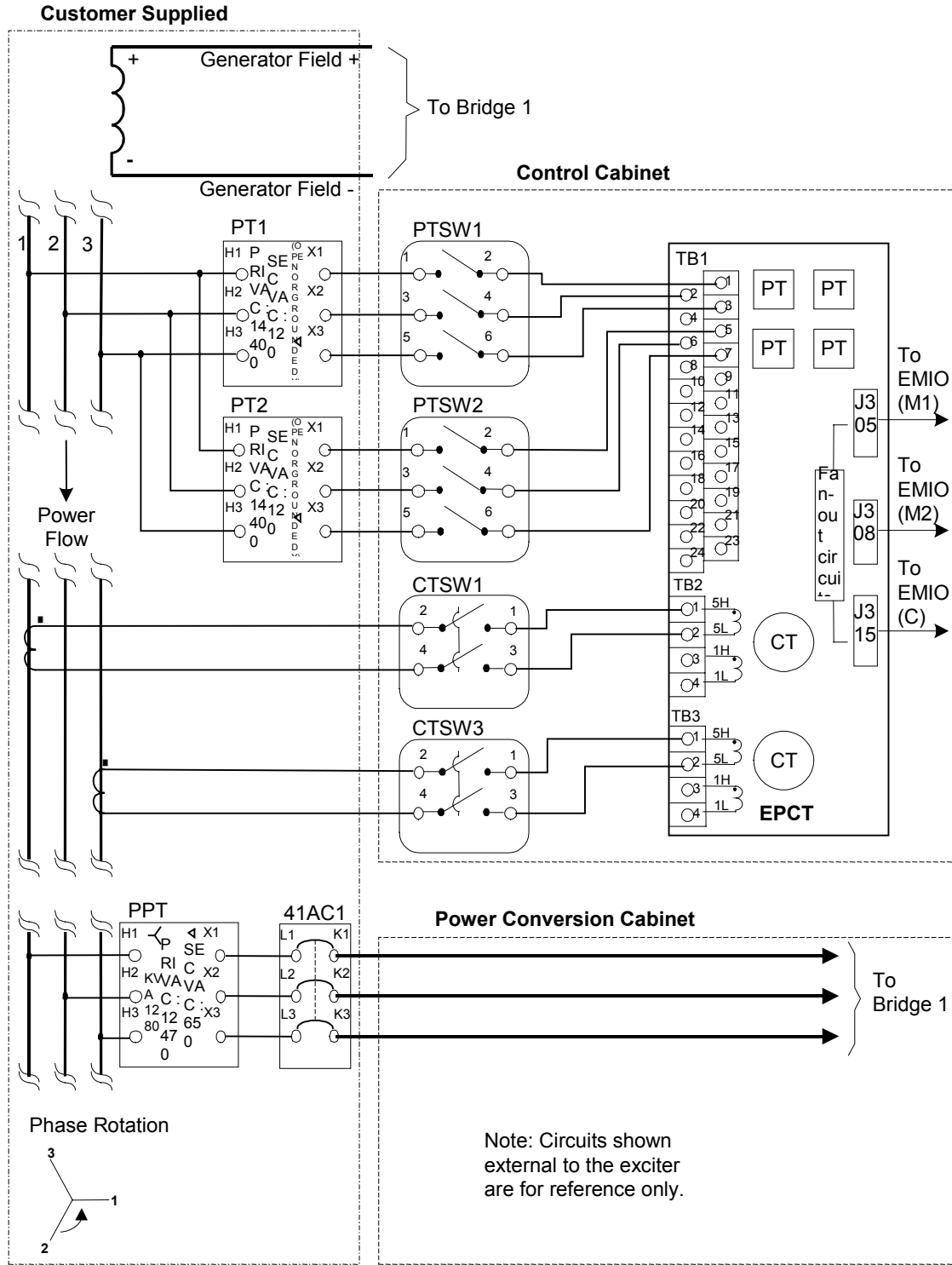

Figure 4-1. Exciter AC Power Supply and PT/CT Wiring

Power Potential Transformer Inputs

In the EX2100 excitation system, a 3-phase source of ac power is converted to a controlled dc output. This ac input can be from one of several sources. Most common is a generator terminal connected Y-Delta power potential transformer. The primary and secondary voltages as well as kVA ratings are sized for the particular application. An auxiliary bus fed PPT is also commonly used. In industrial applications where forcing is needed for large motor starting a compound source (current and voltage) input can be used. This ac input is connected to the bus in the bridge cabinet and can be isolated by the 41AC1 device for maintenance. It is monitored by the controls through the EACF board.

A redundant PT input for PT failure detection is possible, and single-phase sensing can be supported.

Potential and Current Transformer Inputs

Customer supplied 3-phase PT and CT are wired to switches in the control cabinet as shown in Figure 4-1. The switches are wired to the EPCT. High frequency noise suppression near the point of signal entry is provided on all input signals to EPCT. On the board, the two 3-phase generator voltage inputs, nominal 115 V ac, are brought into PT transformers. Two generator CTs (phases A and C), with either 1 A or 5 A secondaries, are brought into CT transformers. The resulting low voltage transformer output signals are cabled to the EMIO board in the control rack.

Generator Voltage Measurement

The cable lengths from the generator PTs can be up to 1000 ft of #12 AWG wire. The PT secondary outputs are nominally 115 V rms at 50/60 Hz and are fused. On EPCT, the two transformers make a three-wire open delta voltage measurement, yielding 1.533 V rms for a 115 V rms input.

In the case of a simplex system the voltage signals are sent through the J305 connector to the EMIO board in the M1 controller. In the case of a redundant system, the signals are fanned to connectors J305, J308, and J315, and sent to controllers M1, M2, and C.

Item	PT Inputs	CT Inputs
Number of Inputs	2, 3 phases each	2, Phases A and C
Volts or Current	10-200 V rms, 115 V rms nominal	0-2 A, nominal 1A, or 0-10 A, nominal 5 A
Frequency	50/60 Hz nominal	50/60 Hz nominal
Burden	Less than 1 VA	Circuit loading 6.25 VA nominal

Generator Current Measurement

Two generator current inputs from the CTs are wired to non-pluggable terminal blocks, TB2 and TB3 that support ring terminals. The CTs do not have fused secondaries. There is a choice of a 0-1 A rms CT input, or a 0-5 A rms CT input. The cable length from the CT to the EPCT board can be up to 1000 ft., and the wire gage can be up to #10 AWG. The resulting signals are sent to the EMIO board through the same connectors as the voltage signals.

Analog Input

The EPCT board provides an analog input for customer use. This input is jumper selectable for either ± 10 V dc or 4-20 mA. The EMIO samples the input at 2000 samples per second, and the accuracy is better than 1% full scale.

Customer Contact I/O

Customer contact inputs and relay contact outputs are wired to the ECTB board.

In addition to six general purpose contact inputs, there are two dedicated contact inputs, wetted by 70 V dc from the exciter, as follows:

- 86G contact input used as a lockout during normal operation
- 52G contact input gives the online status of the generator

ECTB provides four general purpose Form C contact outputs controlled by EMIO. These are used for 94EX and 30EX and other outputs. For each relay, the coil current and the status of a relay auxiliary contact is monitored. These feedbacks are cabled to EMIO in the controller. Refer to Figure 4-2 and Table 4-1.

Table 4-1. General Purpose Relay Contact Characteristics:

Item	Description			
Customer Power	125 V dc nominal (24 V dc min)			
Relay break characteristic	Resistive load	2 A	28 V dc	
		0.5 A	125 V dc	
	Inductive	1 A	28 V dc	0.007 s (L/R)
		0.1 A	125 V dc	0.007 s (L/R)
Suppression	External suppression supplied by customer on induction loads			

ECTBG1 is the redundant control version of the ECTB. This fans inputs to three connectors J405, J408, and J418 that are cabled to the three controllers. For relay control, the board does two-out-of-three voting, and the 70 V dc and 24 V dc inputs are redundant.

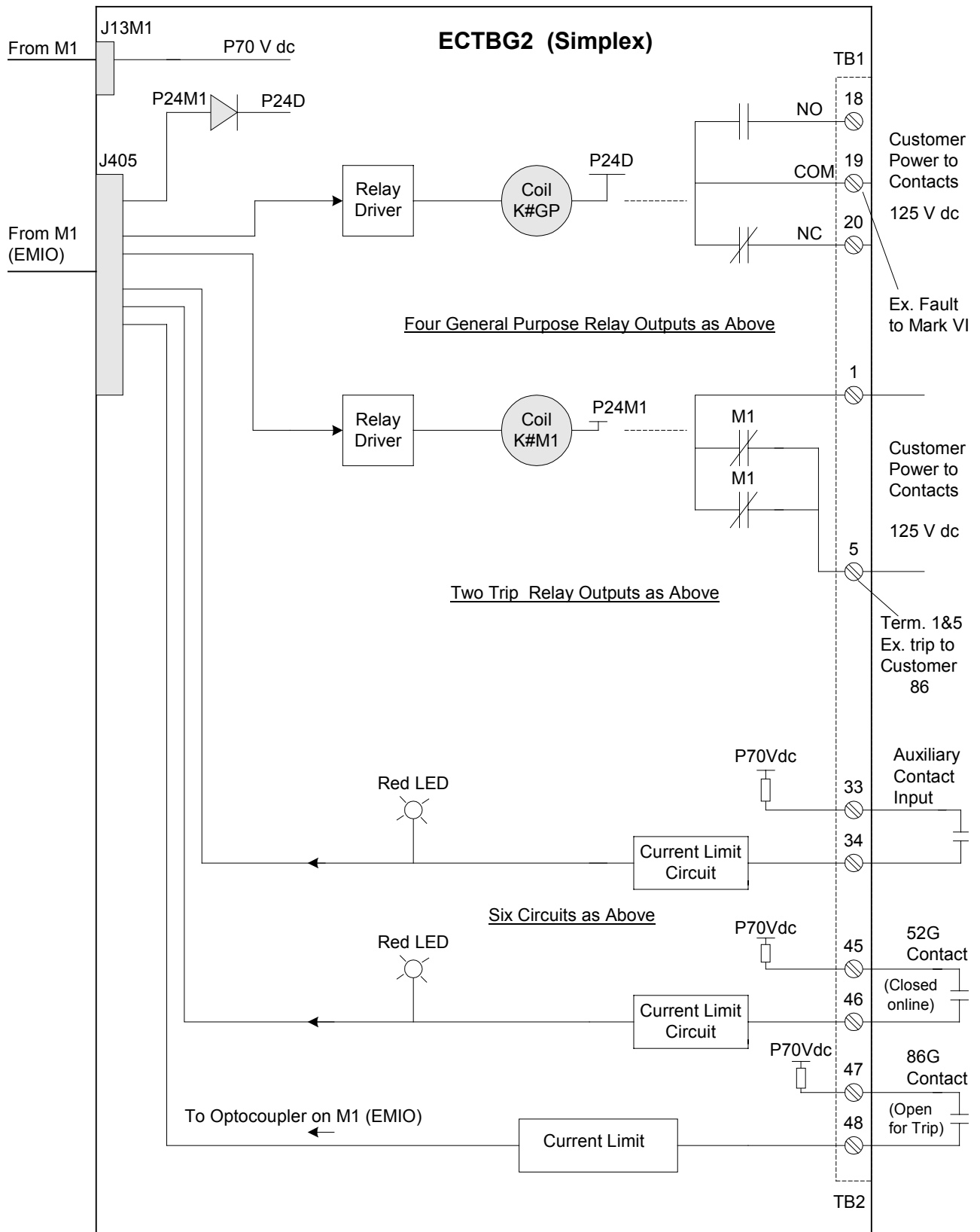

Figure 4-2. Customer I/O wired to ECTBG2 Simplex Board

Power Supply Inputs

The customer's ac and dc power inputs are wired to the exciter's Power Distribution Module (EPDM), which is located on the left hand side of the exciter power backplane rack. Figure 4-3 shows the screw terminals for the 125 V dc battery source, and the 115 V ac supply, AC1. A second ac supply, AC2, can also be connected.

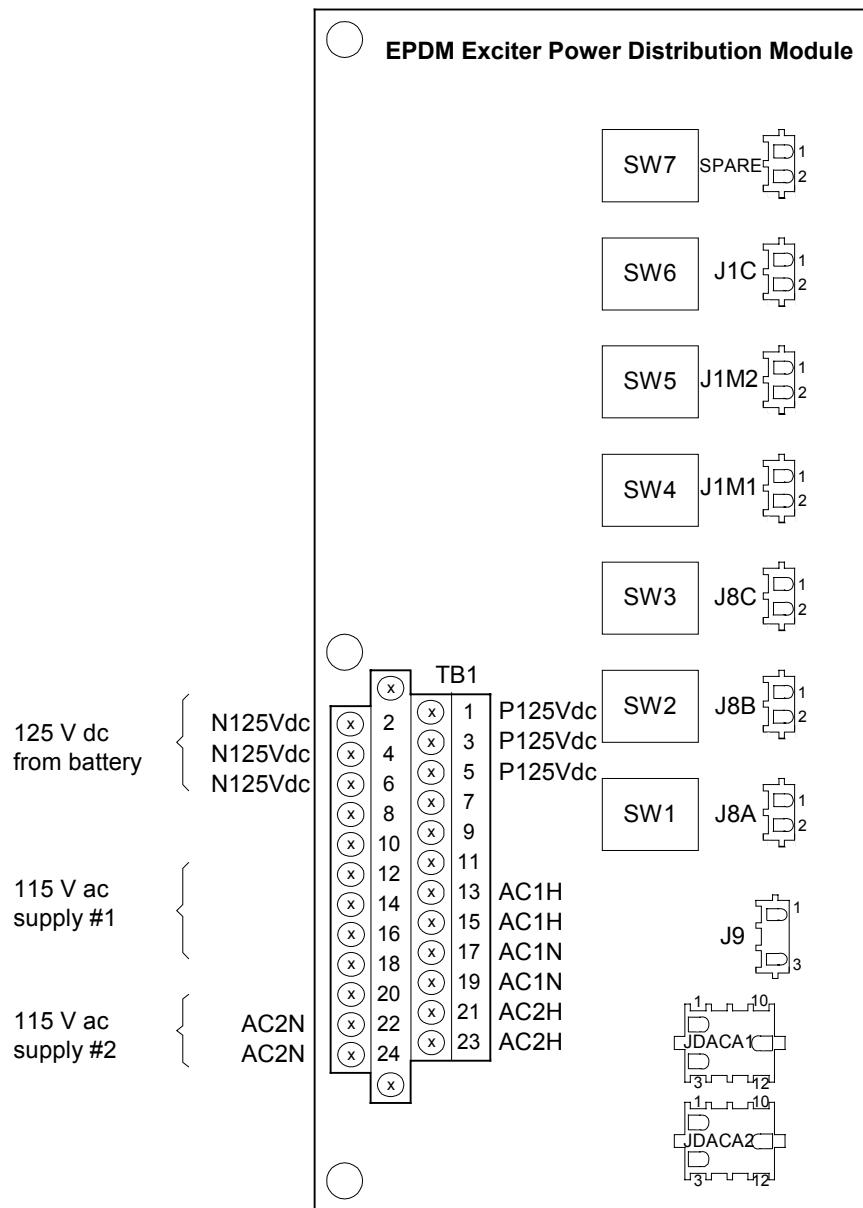

Figure 4-3. Power Wiring Connections to EPDM.

Line Filter Connections

The 600 V filter is connected to fuse board LFU1. The 1000 V filter has two filter circuits and is connected to fuse boards LFU1 and LFU2. The filters are located at the top of the auxiliary cabinet. Connections to the line filter are shown in Figure 4-4.

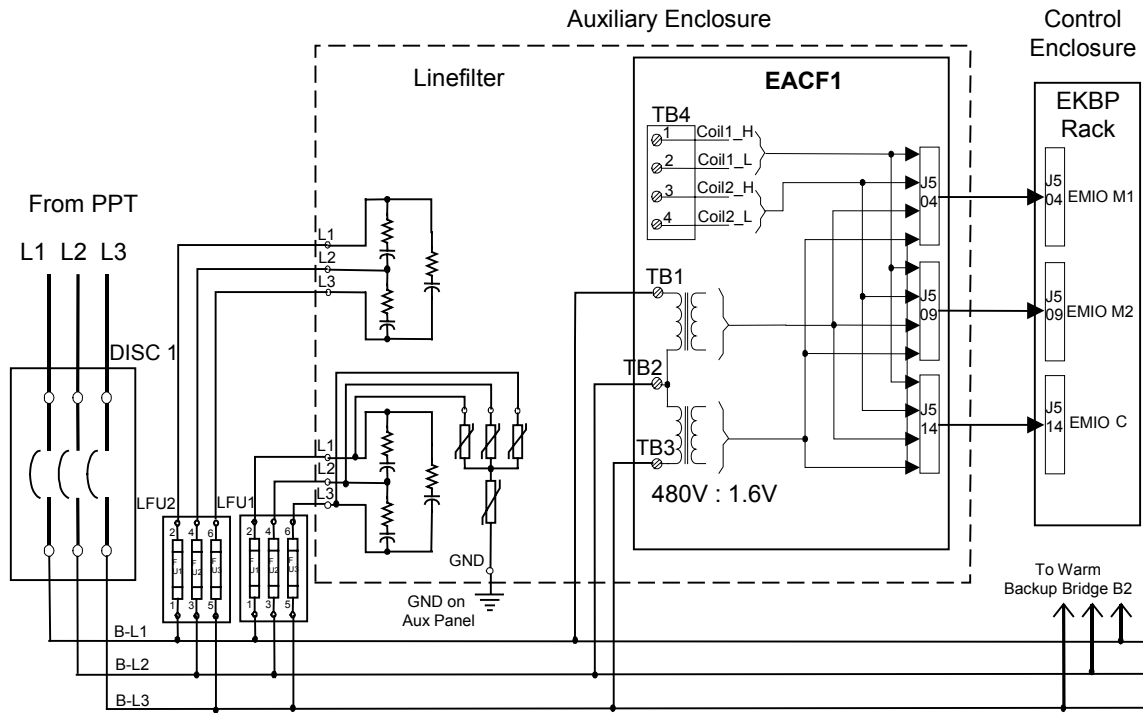

Figure 4-4. AC Feedback and Line Filters

Exciter Internal I/O

Exciter AC Feedback

The EACF board measures the exciter ac supply voltage and current. The terminal board contains transformers for a 3-phase voltage measurement, and terminals for two flux/air core coils. The cable between EACF and the EBKP control backplane can be up to 90 m in length. Cable shield terminal screws attached to chassis ground are located within three inches of the input screws where applicable. There are two versions of the circuit board, EACFG1 for up to 480 V rms inputs, and EACFG2 for up to 1000 V rms inputs. Refer to Figure 4-4.

Exciter DC Feedback

The EDCF board measures field current and field voltage at the SCR bridge, and interfaces to the EISB board in the controller over a high-speed fiber-optic link. The fiber optics provides voltage isolation between the two boards, and high noise immunity. For a circuit block diagram, refer to Figure 4-5. The field voltage feedback circuit provides seven selector settings to scale down the bridge voltages appropriate to the application.

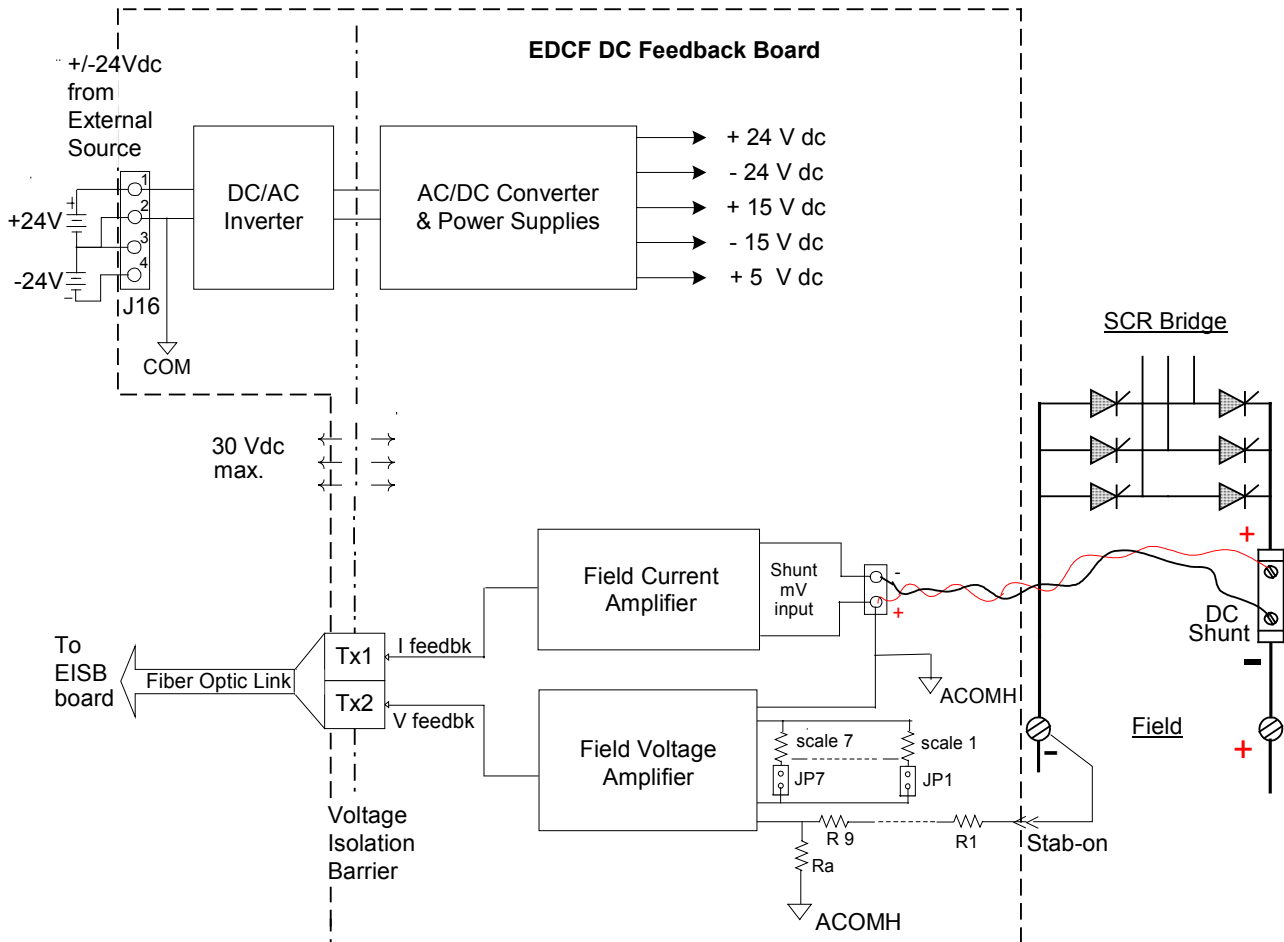

Figure 4-5. Field Voltage and Current Measurement

Field Current Feedback

The field current is measured across a dc shunt at the SCR bridge. This generates a nominal 100 mV signal, which is input to a differential amplifier. The output voltage from the amplifier ranges from -5 V to $+5\text{ V}$. A VCO produces a linear proportional frequency of 0 to 2 MHz with an accuracy of 1% of full scale reading. These pulses drive the LED in the optical isolator coupled to the fiber-optic cable.

Field Voltage Feedback

The bridge voltage is measured across the negative terminal of the bridge and the positive terminal of the current shunt. After scaling the voltage with the jumpered resistors, the signals are input into a differential amplifier which controls the voltage-controlled oscillator (VCO). The VCO produces a linear proportional frequency of 0 to 2 MHz with an accuracy of 1% of full-scale reading. The pulses drive the LED in the optical isolator coupled to the fiber-optic cable.

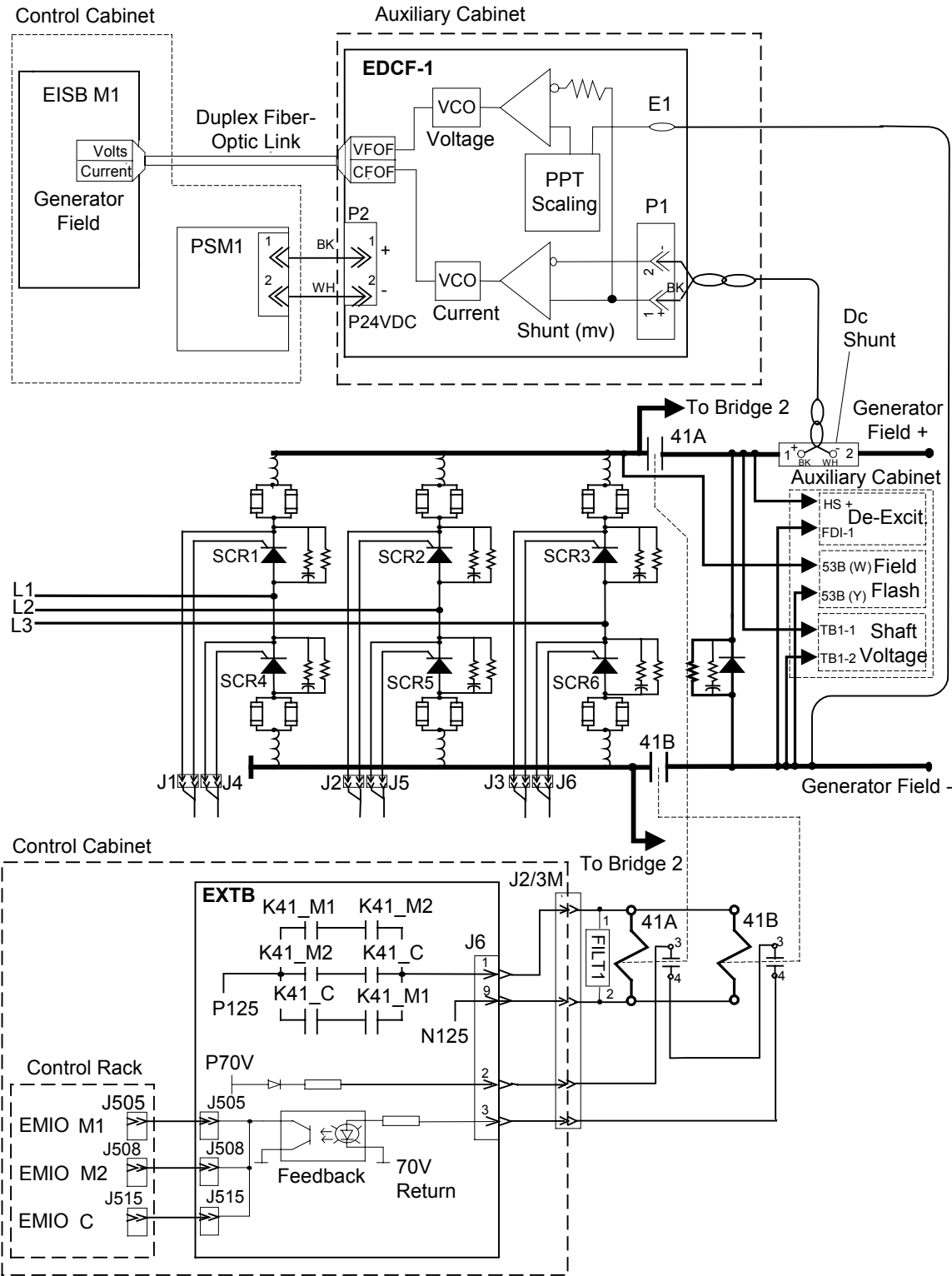

Figure 4-6. DC Field Circuit Contactor and Control Board

De-Excitation

During shutdown of the generator, the stored energy of the generator field inductance must be dissipated. In the EX2100 exciter, this is the function of the EDEX de-excitation module and field discharge resistor or inductor (when supplied).

Standard de-excitation is provided by a freewheeling diode. For higher performance applications, the de-excitation module consists of a thyristor (53 mm or 77 mm cell size) mounted in a large heatsink assembly with attached snubber network.

The EDEX board contains Hall effect conduction sensors. The sensors are mounted in the air gap of a circular steel core attached to the board. They sense the magnetic field produced by the field discharge current flowing through the thyristor. Two independent sensor circuits are used. The EDEX fires the SCR when either of two control inputs is true or when the anode to cathode voltage of the SCR exceeds a certain value. The two firing control circuits on the board are powered from separate power supplies and use separate conduction sensors making them mutually independent.

The actual control logic inputs used are dependent on the application. When the exciter shuts down, a P24 V firing control signal is sent to both de-excitation module firing control circuits. Both firing control circuits send gate pulses to fire the de-excitation SCR. At this point, the main field polarity reversal has occurred making the SCR anode positive with respect to the cathode. Therefore the SCR conducts and dissipates the stored energy of the generator field through the field discharge device.

Feedback from either conduction sensor verifies that the discharge circuit has operated successfully. If both independent firing control circuits fail to fire, the SCR is fired by the anode firing circuit when the anode to cathode voltage has exceeded the selected level.

For large exciters, it is possible to connect multiple de-excitation modules together with one EDEX board configured to be the *Master* and the other boards configured to be *Slaves*. In this case, a firing control signal sent to the *Master* is relayed to the *Slave* modules, firing all modules simultaneously.

EXTB controls the main breaker or contactor in the field circuit. When this opens, the auxiliary contacts cause an immediate de-excitation commanded by EDEX. De-excitation controlled by EXTB in both the contactor and breaker mode is shown in Figures 4-7, and 4-8.

Location of the 41A dc contactor in the field circuit is shown in Figure 4-6. Contactor 41B is optional. Both contactors are located in the Power Conversion Cabinet, and are driven from the 41 Close pilot on the EXTB board. Several auxiliary contacts are used to provide status feedback to the control, and firing commands to the de-excitation board, EDEX.

An alternative to an 41A and 41B contactor is to use a breaker in the excitation ac supply or dc field circuit. Normally, the breaker would be a dc field breaker that could break the output while inserting a discharge resistor with the normally open contact. But, an ac break with the SCR based de-excitation module could also be applied. The breaker has two coils, 41 Close and 41 Trip, and auxiliary contacts for de-excitation. Figure 4-8 shows how the breaker interfaces with the EXTB control board and EDEX.

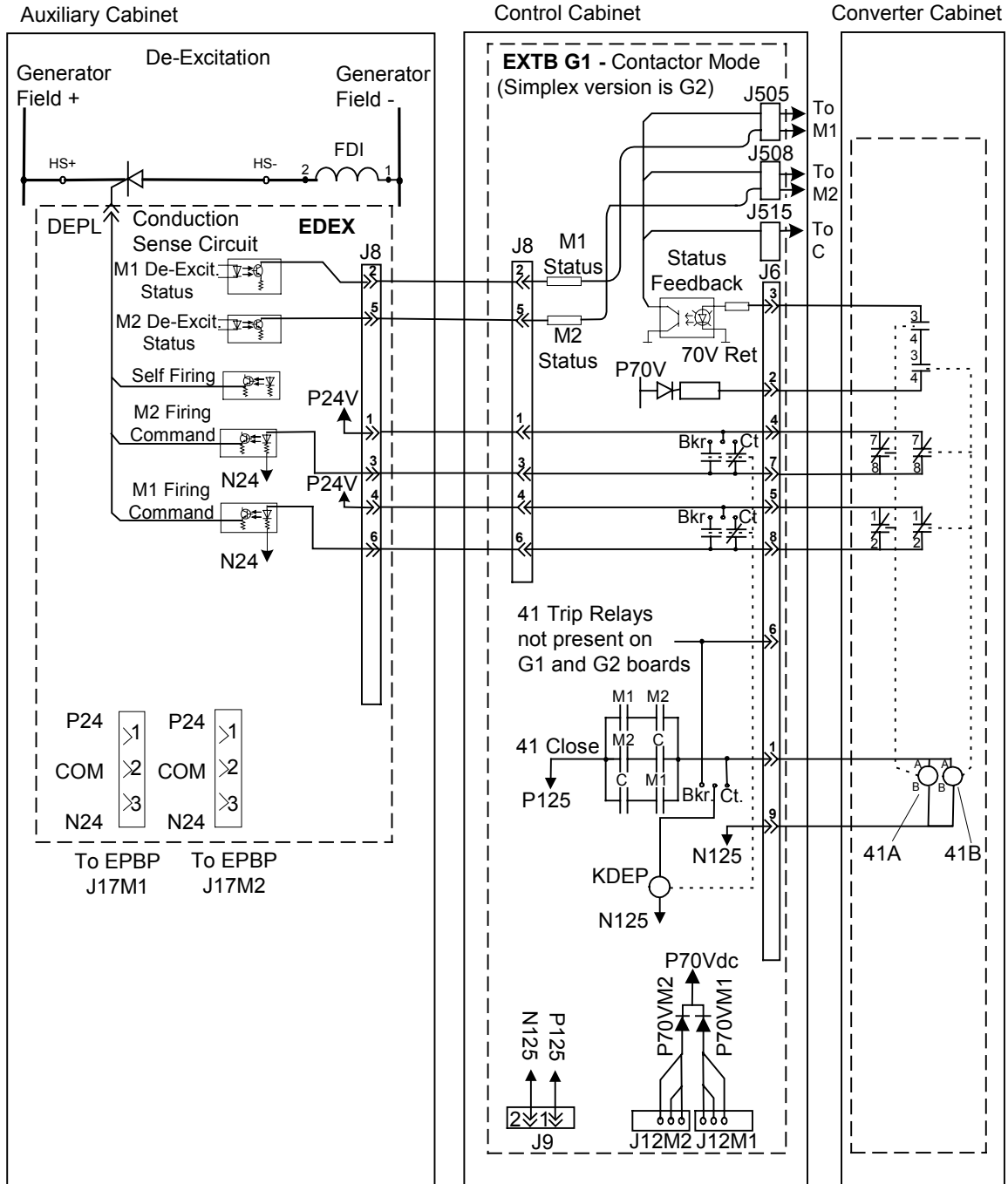

Figure 4-7. DC Contactor Control and Wiring to De-Excitation Board

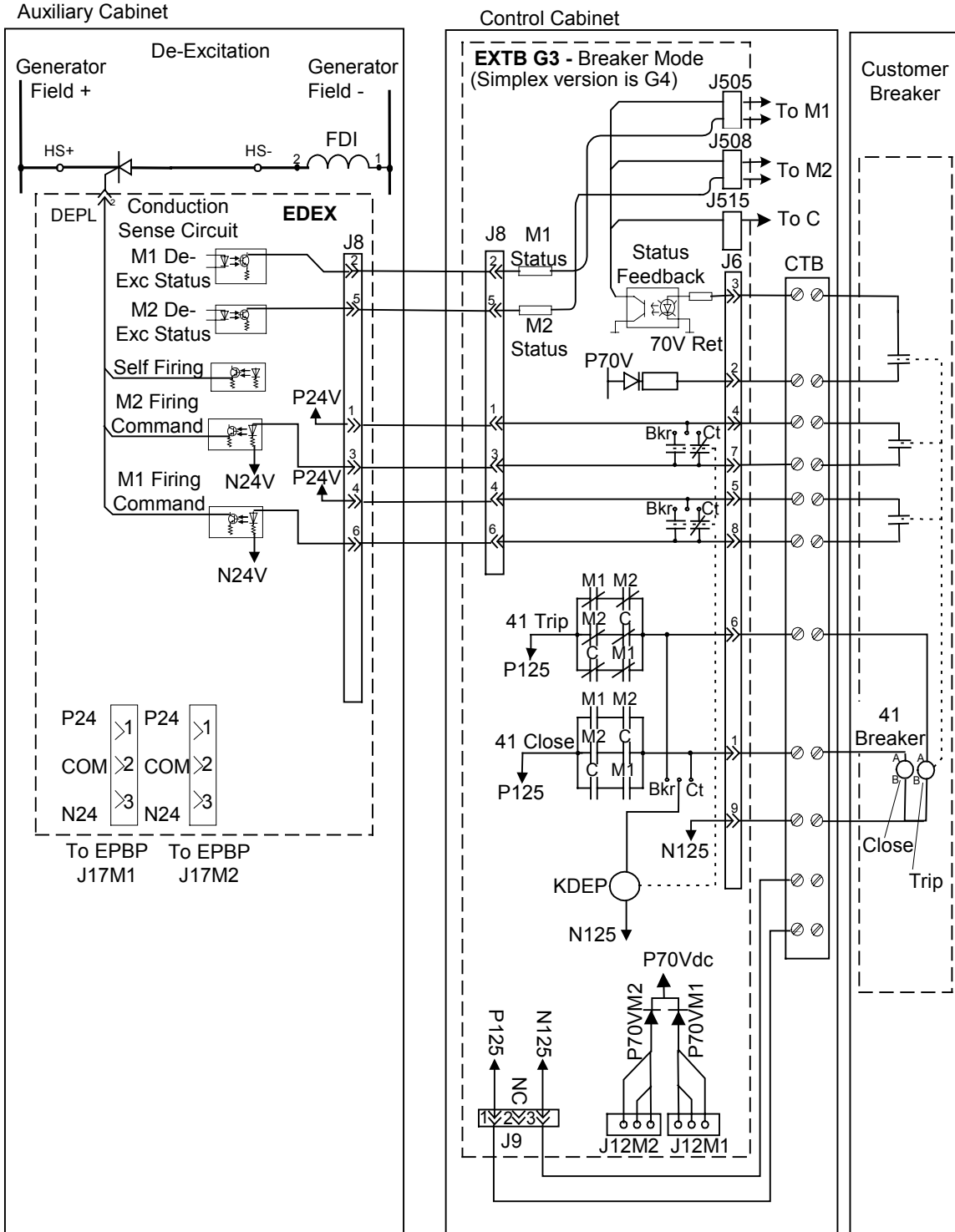

Figure 4-8. Ac or Dc Breaker Control and Wiring to De-Excitation Board

Crowbar

The optional crowbar subsystem limits high negative voltages that can be induced into the PCM during a pole slip (loss of synchronization) event. Like the de-excitation module, the crowbar will self-fire based on selective field voltage limits. It includes a discharge resistor, which may be shared with the de-excitation function when the two are supplied together. This is typically only provided on generators with salient poles (hydro applications).

Field Ground Detector

The EGDM is an active system that applies a voltage to the field circuit.

The generator field is an ungrounded system. The field ground detector (EGDM) detects field leakage resistance between any point in the field circuit of the generator and ground. The active detection system shown in Figure 4-9 applies a low frequency square wave voltage with respect to ground, and monitors for current flow through a high impedance ground resistor. The square wave is ± 50 V dc at 0.2 Hz frequency. If PRV resistors are present, grounds anywhere in the system can be detected even while the exciter is not being fired, from the PPT secondary to any point in the generator field.

The ground detector feedback voltage is sent over a fiber-optic link to the DSPX where it is monitored and alarmed. The DSPX controls the oscillator voltage over an adjacent fiber-optic link. In the case of redundant control, if the M1 controller fails, the oscillator in the M2 channel takes over, as commanded by controller C.

One or three EGDMs are mounted next to the power supplies in the power backplane.

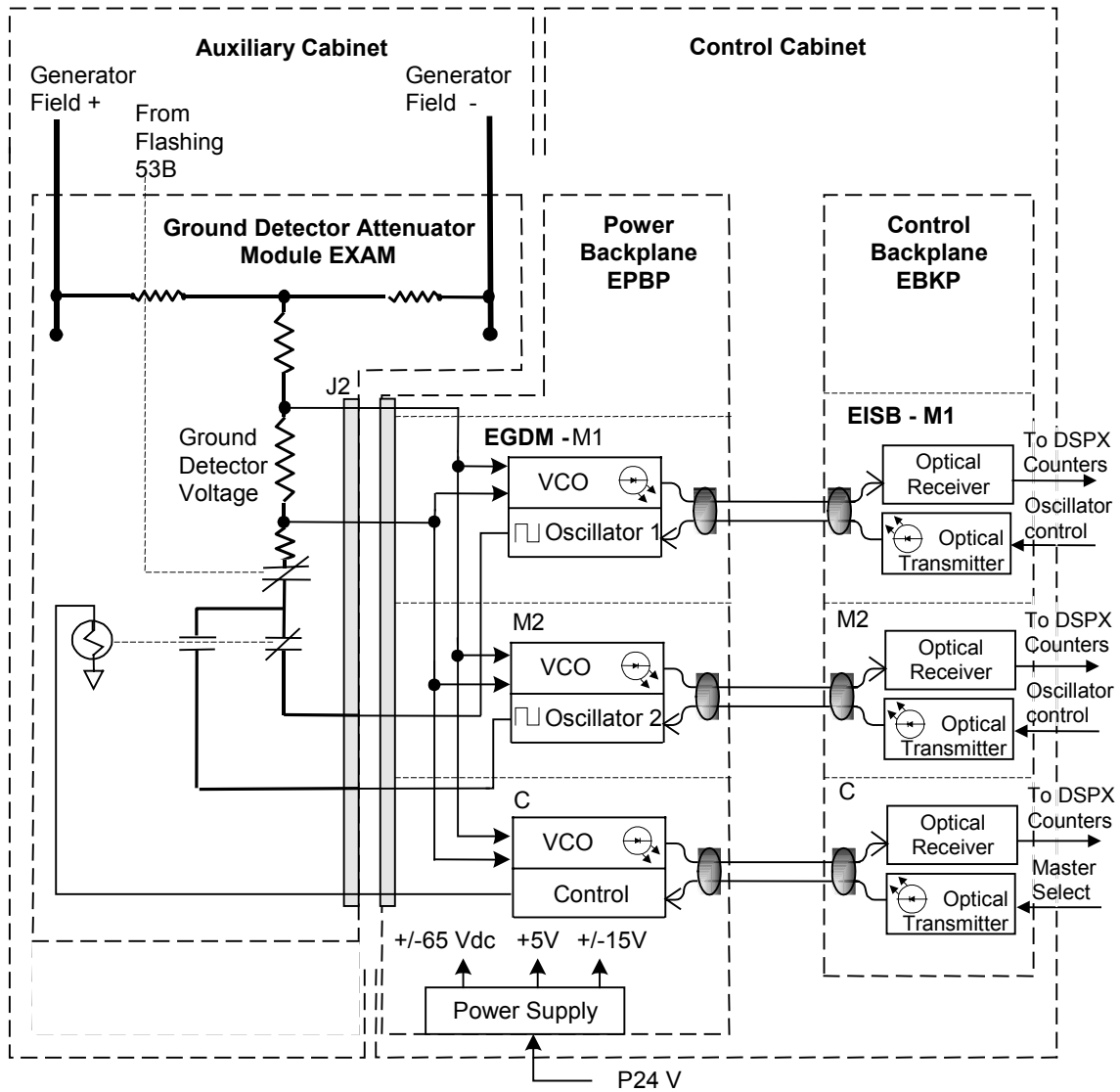

Figure 4-9. Field Ground Detector

Field Flashing

The station battery is used to initiate the field current. An auxiliary ac source can also be used.

Field flashing relays 53A and 53B are controlled from drivers on the EMIO board, through pilot relays on EXTB. In redundant control, the three driver signals actuate pilot relays on EXTB that are contact voted to output a single voltage. These outputs actuate the 53A and 53B relays in the Auxiliary Cabinet. The 53A and 53B contacts put dc voltage from the station battery across the generator field, as shown in Figure 4-10. The field flashing module supplies approximately 15 to 20% of AFNL to the generator field during the startup sequence.

For ac field flashing, the ac voltage is rectified by a diode bridge and filtered. The startup sequences and logic are the same.

Dc Field Flashing Settings

Field flashing panels are used to supply a wide range of flashing currents. This happens if the flashing control fails, leaving the flashing current on continuously. The flashing current magnitude required for a generator is set by configuring a maximum and minimum allowable value in the control module.

The current values are preset in the factory based on information supplied. These values define the envelope in which the hysteretic flashing control holds the field current during the flashing sequence.

Flashing Control Sequence

A start request is issued by the operator. The optional field contactor(s) closes, followed by contactor 53B, then 53A. When the field current reaches the maximum allowable field flash value (typically 15 - 20% of AFNL), contactor 53A opens and the field current decays through the freewheeling diodes. If the control has not taken over before the current decays to the minimum field flash current setting, typically 10% AFNL, the sequence is repeated. If the current magnitude exceeds approximately 25% AFNL, or the control has not taken over after a fixed time delay, the startup is stopped and a diagnostic alarm is issued.

Flashing current flow is monitored by the control through the field shunt.

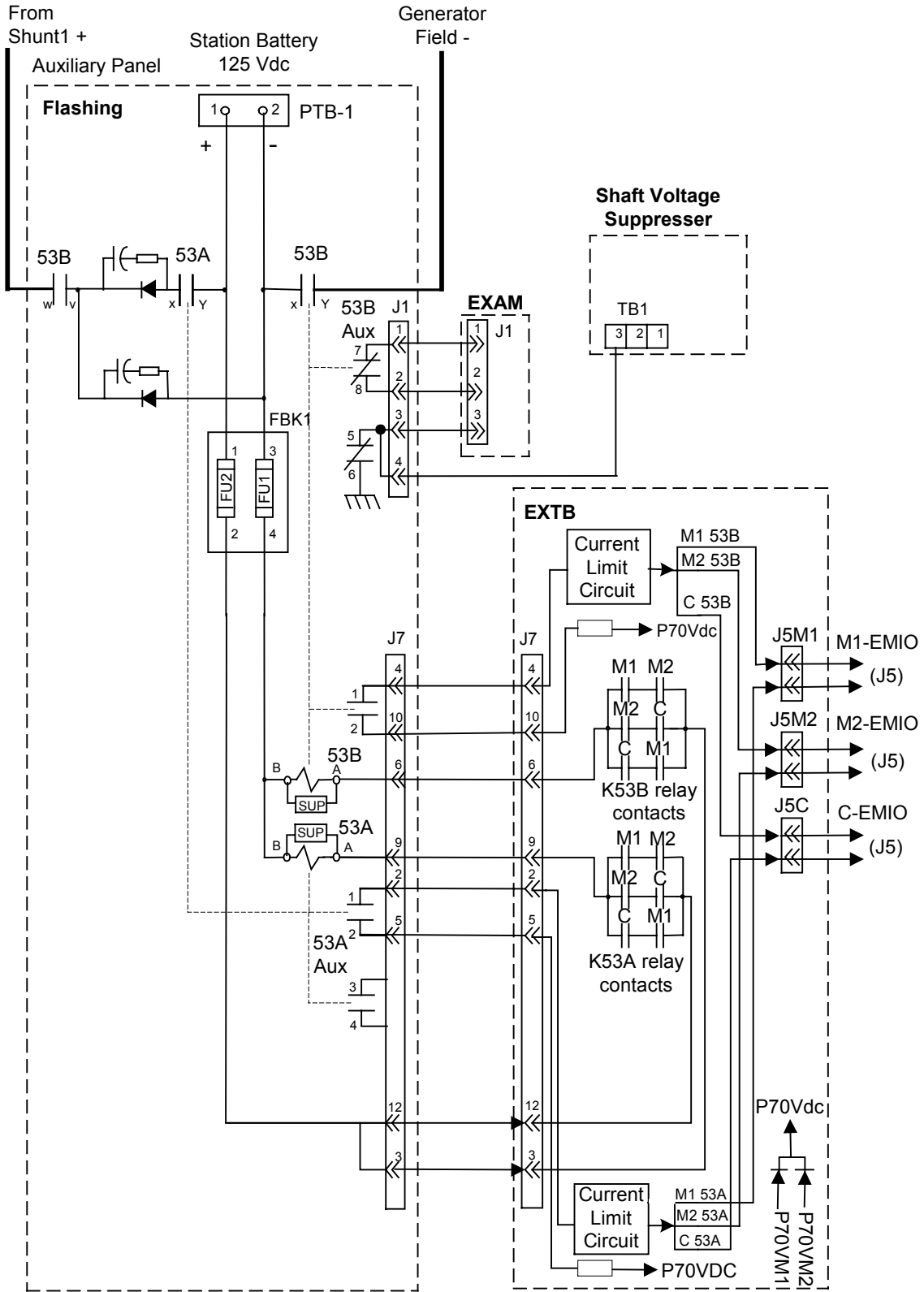

Figure 4-10. Field Flashing Control from EMIO and EXTB

Shaft Voltage Suppressor

Excitation systems, which produce a dc voltage from an ac supply through a solid state rectification process, cause ripple and spike voltages at the exciter output. Due to their rapid rise and decay times these voltages are capacitively coupled from the field winding to the rotor body. This creates a voltage on the shaft relative to ground that, if not effectively controlled, can damage both journals and bearings. The shaft voltage suppressor is a filter that conducts the high frequency components of the induced voltages to ground and limits shaft voltage caused by thyristor commutation to less than 7 V zero to peak. For the connections to the field, refer to Figure 4-11.

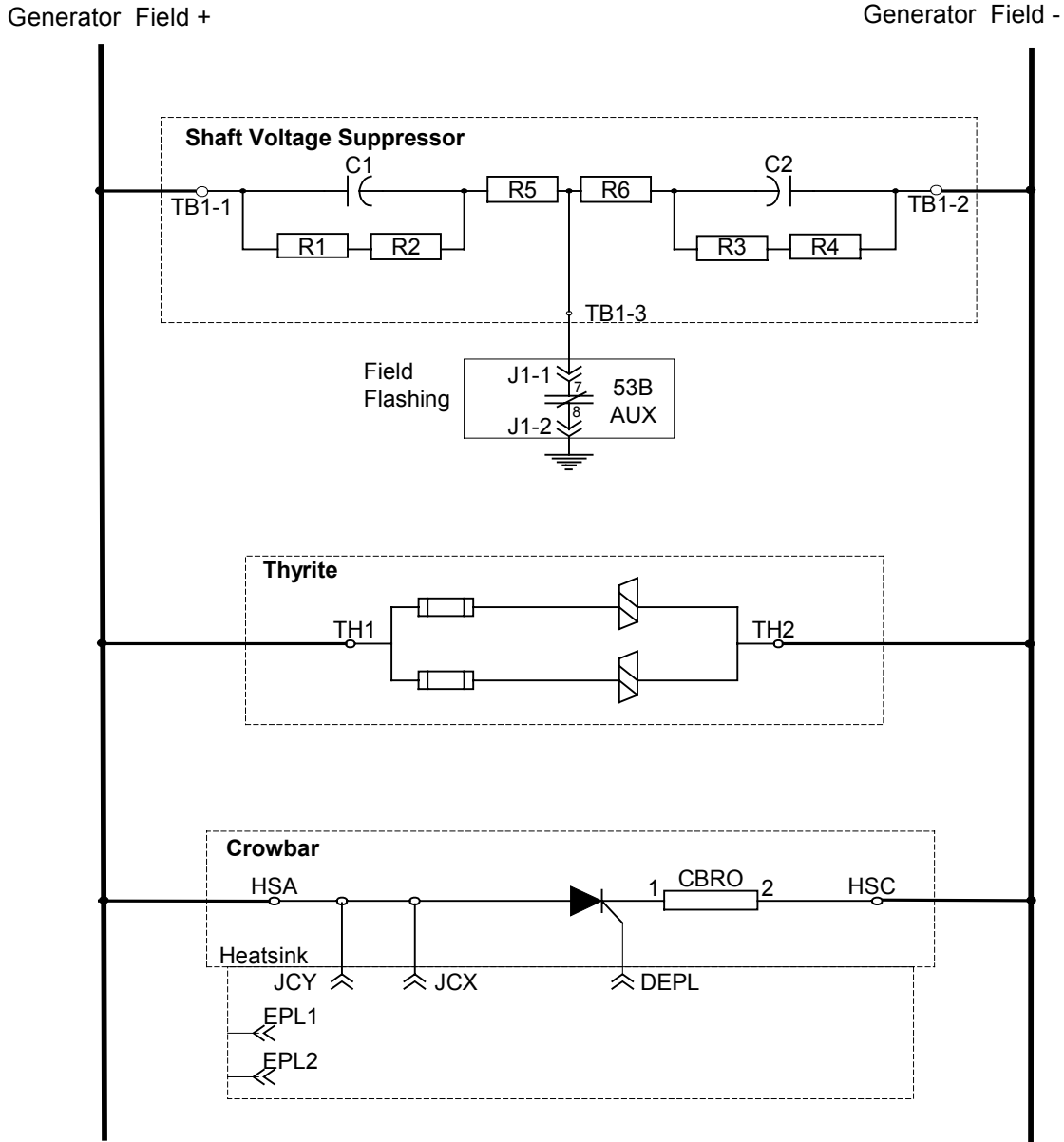

Figure 4-11 Shaft Voltage Suppressor, Thyrite, and Crowbar

Data Highway Connections

The Data Highway integrates several different single control systems.

The EX2100 exciter communicates over the same data highway as the Mark VI turbine control and the HMI. A typical exciter connection to the redundant Unit Data Highway (UDH) network is shown in Figure 4-12. This shows redundant control with two ACLAs. The UDH is implemented using commercially available fast Ethernet switches.

10Base-T cabling is used for short distances between the controller and the T-switch, and any local HMI. The 10BaseT ports in the ACLA and the T-switch are for RJ-45 connectors. The maximum distance for local traffic at 10 Mbps using unshielded twisted pair cable is 100 m.

100Base-FX fiber optics can be used for longer distance communication between the local controllers and the central control room. The 100BaseFX ports in the T-switch and the Ethernet switch are for SC type fiber-optic connectors. The maximum distance at 100 Mbps using 100BaseFX fiber-optic cables is 2 km. Redundancy can be obtained by using two T-switches with an interconnecting cable.

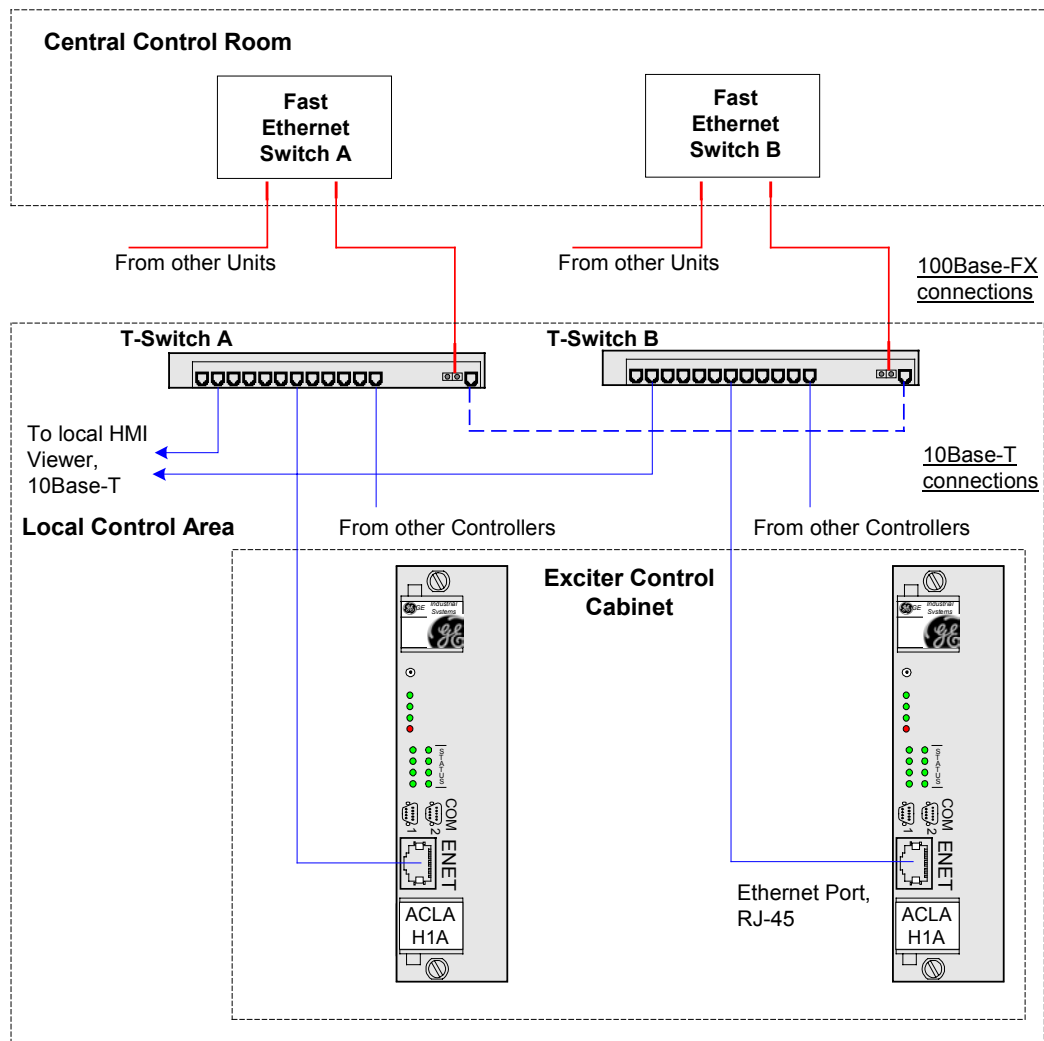

Figure 4-12. Unit Data Highway Connections

Control System Toolbox Connection

The toolbox connector on the exciter backplane supports an RS-232C cable, which connects an external computer to the DSPX board. This connection is for maintenance purposes. There are three 9-pin connectors located at J303B, J310B, and J313B to support communication with controllers M1, M2, and C. (Refer to Figure 4-13).

The UDH can also provide a toolbox interface using the Ethernet port on the ACLA. This is a 10BaseT port and uses an RJ-45 connector for unshielded twisted pair cable.

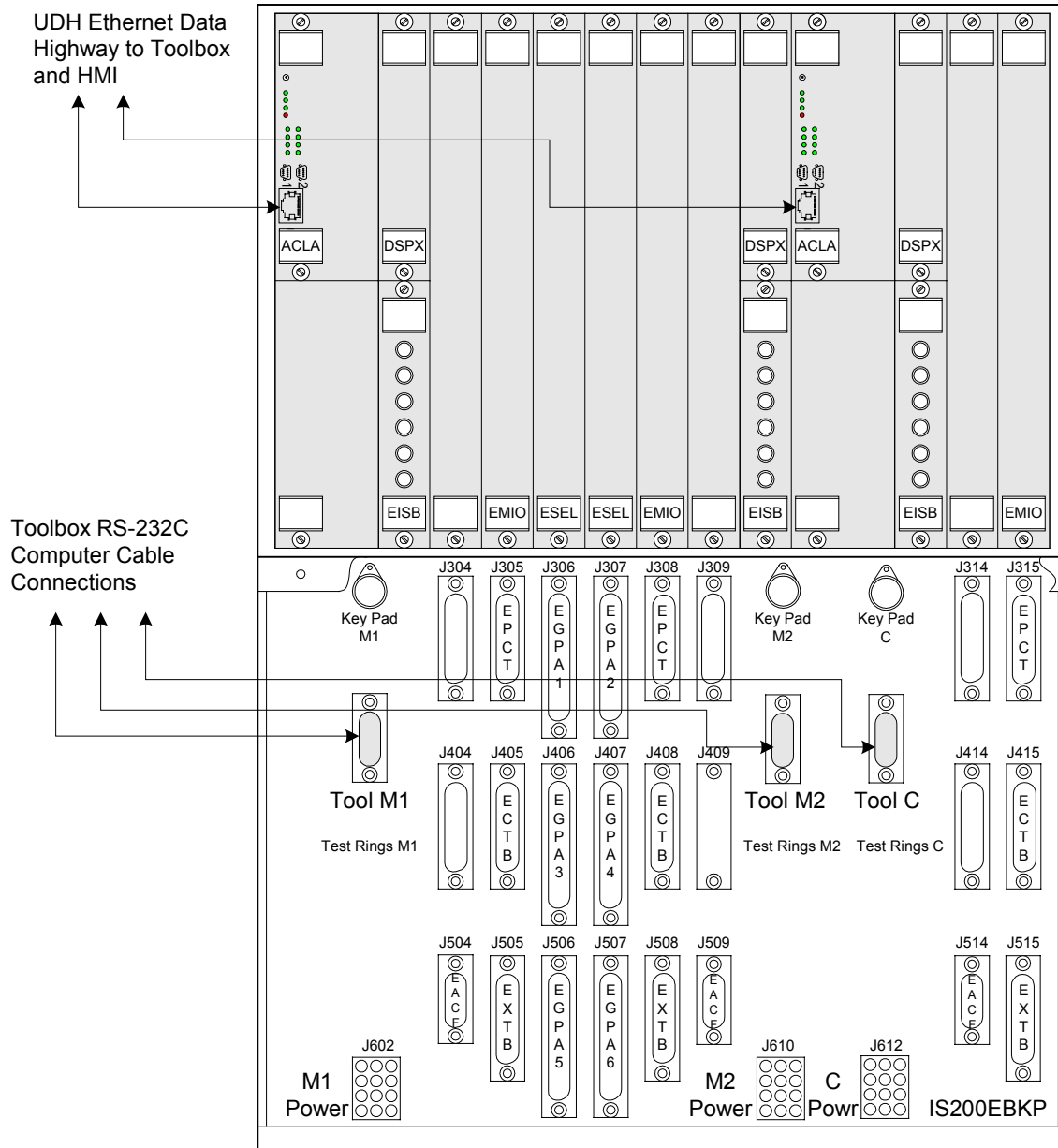

Figure 4-13. Toolbox Connections

Chapter 5 Diagnostic Interface-Keypad

Introduction

This chapter provides operating guidelines for the Diagnostic Interface, more commonly called *the keypad*. The keypad is a door-mounted, local control unit that enables you to:

- Monitor frequency, current, power, and voltage
- Start and stop the exciter
- Set and adjust configuration parameters
- Examine and reset fault conditions

This chapter is organized as follows:

Section	Page
Using the Pushbuttons.....	5-2
Reading the Display.....	5-5
Changing Display Units.....	5-7
Adjusting Display Contrast.....	5-7
Status Screen.....	5-8
Reading the Meters.....	5-8
Alternate Status Screen (Display I/O).....	5-8
Using the Menus.....	5-9
Viewing and Resetting Faults.....	5-9
Editing Parameters.....	5-10
Parameter Backup.....	5-11
Firmware and Hardware Information.....	5-13
Protecting the Keypad.....	5-14
Modifying the Protections.....	5-14

Using the Pushbuttons

The keypad includes membrane-type pushbuttons to access exciter values and to control the exciter. Tables 5-1 and 5-2 define the pushbutton functions for menu navigation and exciter control (see Figure 5-1).

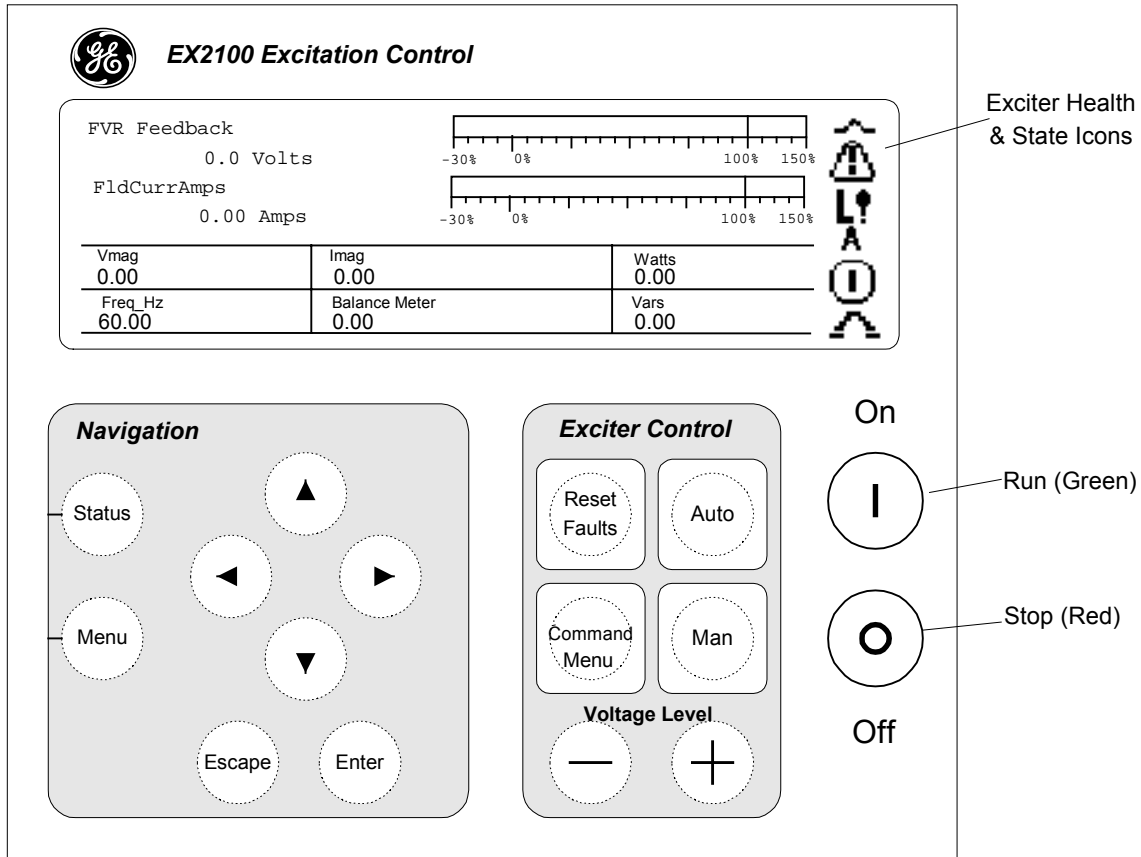

Display:

Status screens provide analog and digital representation of exciter functions and values.

Menu screens provide text-based access to parameters, wizards, and faults.

Pushbuttons:

Organized into functional groups:

Navigation buttons for using the menu

Exciter Control buttons

Run and **Stop** buttons

Figure 5-1. Diagnostic Interface - Keypad

Table 5-1. Navigation Pushbuttons









Button	Function
	Displays the default Status Screen, which shows eight parameters as numbers or bargraphs. A set of Health icons (displayed at all times; see <i>Exciter Health and State Icons</i>) provides additional exciter status information.
	If pressed while displaying a Menu screen (see <i>Menu Selections</i>), displays the Main Menu. If pressed while displaying a Status screen, displays the last Menu screen. If held down, the up and down arrow keys adjust screen contrast
 	Menu Navigation: Used to highlight (reverse image) an item in a menu of options. Adjust Contrast, if menu key is held down. Entry of Numeric Parameter: Used to index through numbers (0-9, ., -) when editing a parameter. Entry of Option Parameter: Used to index through 1 – n choices. (See <i>Parameter Configuration</i> .)
 	Menu Navigation: Right Arrow button displays the next selected level down in a menu tree. Left Arrow button displays next level up in menu tree. Entry of Numeric Parameter: Used to select a digit when editing a parameter. Entry of Option Parameter or Command Execution: Not functional.
 	Menu Navigation: Displays the next level up in menu tree. Entry of Parameter: Displays the parameter list. Menu Navigation: Displays the next level down in menu tree. Entry of Parameter: Accepts editing of parameter.

Table 5-2. Exciter Control Pushbuttons

Button	Function
	Resets faults.
	Quick access to a list of commonly used commands
	Selects Auto mode (AC regulator or AVR)
	Selects Manual mode (DC regulator or FVR)
	Increase voltage, VARS, PF
	Decrease voltage, VARS, PF
	Run
	Stop

Reading the Display

The keypad displays information as both text and animated graphics. There are two types of content screens, selected by pressing the corresponding Navigation button: Status and Menu.

The **Status Screen** (Figure 5-2) is the default screen that displays after exciter startup, following an initialization screen. It uses animated meters with associated text to present exciter performance data. An alternate Status Screen can also be accessed (see *Status Screen*).

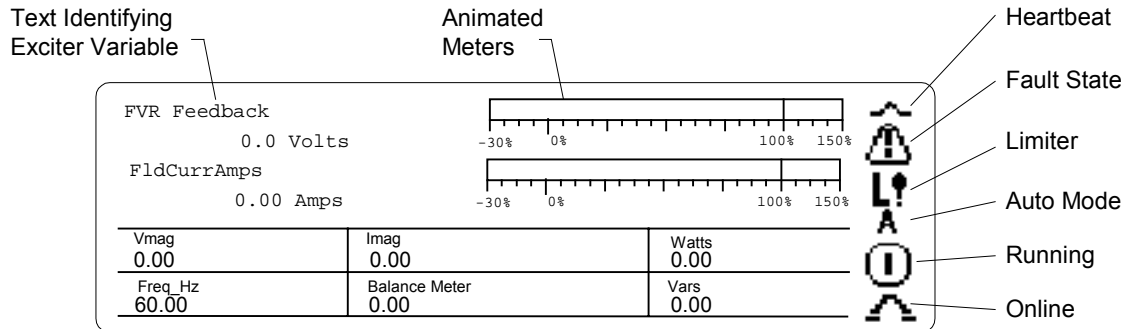

Figure 5-2. Status Screen Example

The **Menu Screen** (see Figure 5-3) lists and provides access to menu-based functions for adjusting parameters, running wizards, and viewing faults (see *Menu Selections*).

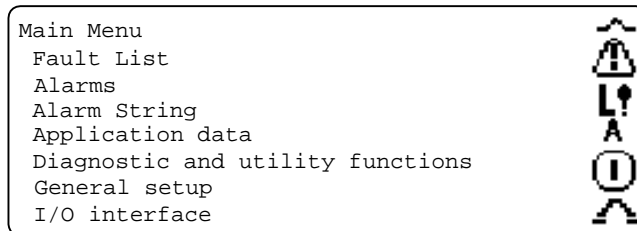















Figure 5-3. Menu Screen Example

The **Exciter Health and State Icons** continually show on the right hand side of all display screens. They indicate if the exciter is functioning correctly and show its running state. These icons are displayed in five functional groups, as shown below. You can change the **display units** and adjust the **display contrast**, if needed.

Table 5-3. Exciter Health and State Icons

Group	Icon	Indication	Description
Heartbeat		Communications OK	Animated line (its center raises and lowers) shows that there is communication between the keypad and the exciter.
		Communications not established	Animated metronome icon shows that the keypad is attempting to establish communication with the exciter, but cannot.
Control		Auto mode	Regulates terminal voltage.
		Manual mode	Regulates field voltage.
		Test Mode	The exciter is performing a diagnostic test.
Fault State	Blank	Exciter OK	When no icon displays, the exciter is operating correctly.
		Abnormal	Displayed when there are over-ridden parameters.
		Alarm state	Displayed when an alarm condition occurs.
		Trip fault	Displayed when a fault state occurs.
Status		Stopped	Exciter is stopped.
		Running	Exciter is running.
		Limiting	Field voltage regulator output is greater than field current regulator or V/Hz or UEL limits are active.
		Offline	Exciter is offline.
		Online	Exciter is online.

Changing Display Units

➤ **To change the type of measurement units displayed**

1. From the Main Menu, select **General Setup**.
2. Select **Display Units**.
3. Select the display units parameter to edit it (see below).
4. Highlight, then select the preferred display units.

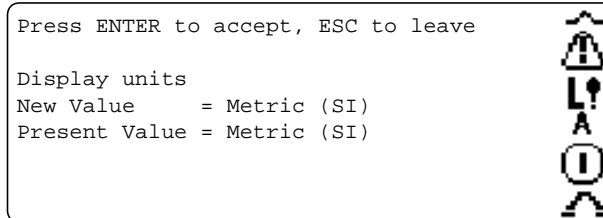

*Shortcut – Press and hold the **Menu** key. Press the **Up** and **Down** arrows to adjust the display contrast.*

Adjusting Display Contrast

➤ **To adjust the display contrast**

1. From the Main Menu, select **General Setup**.
2. Then select:
 - a. **Keypad**
 - b. **Keypad Functions**
 - c. **Adjust Screen Contrast**

This displays the following screen.

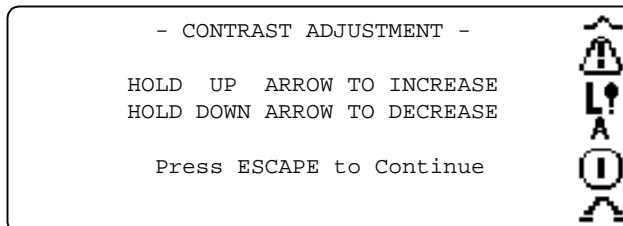

3. Press the **Escape** button to save the contrast value and return to the previous menu.

Status Screen

The Status screen displays up to eight **variables** (parameters). The first two parameters are displayed both in text and animated meters. Table 5-4 defines the characteristics of the bar graphs for these parameters.

Reading the Meters

A variable shown as a bar graph is **over range** when it is either greater than + 100% or less than -100%. The over range mark is shown with a vertical bar through the bar graph at the +100% and the -100% marks.

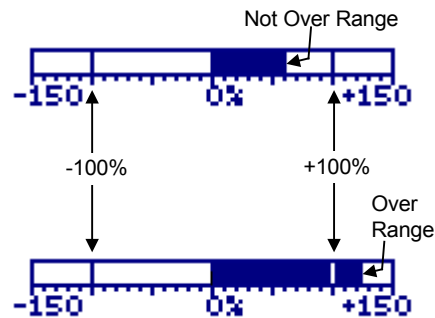

Table 5-4. Animated Meter Characteristics (Default) for Status Screen

Bar Graph Variable	Numeric Display	Units in Bar Graph
DC bus voltage	Magnitude of dc bus voltage (FVR feedback)	Percentage of dc per unit volts (VDC_PU)
AC line current	Magnitude of ac line current (I_Mag_Fil)	Percentage of source top-rated current (I_PU)

Alternate Status Screen (Display I/O)

The keypad has an **alternate** Status screen that displays the status of the general purpose inputs and outputs. To toggle between the Meter Status Screen and the I/O Status Screen, press any of the **Arrow** buttons.

The circle under each heading indicates the status of the corresponding I/O point, as follows:

- ● = True
- ○ = False

Display I/O Status						
	1	2	3	4	5	6
GP Inputs	●	○	○	○	○	●
GP Outputs	○	●	○	○		

Using the Menus

The keypad's Main Menu leads to other menu screens, where data can be reviewed and modified. The Main Menu can be accessed from any screen, as follows:

- If already in a Menu screen, press the Menu button.
- If in a Status screen, press the Menu button once or twice.

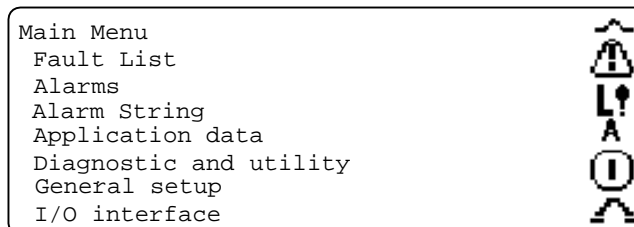

Note The Main Menu selections may vary from product to product.

Use the **Navigation** buttons to move through the menus, select items, and adjust values

- Press the **Up** or **Down Arrow** buttons to move through and highlight menu items.
- Press the **Enter** button to select a highlighted item
- To return to a previous menu screen, press the **Escape** button, **Left Arrow** button, or follow on-screen instructions.
- When a menu has more than one screen:
 - Move to the next screen by highlighting the last item on the displayed screen, then press the **Down Arrow** button once more.
 - If the last menu item is reached, then pressing the **Down Arrow** button will wrap back to the first item on that menu.

Viewing and Resetting Faults

When the display indicates either a **Trip** or an **Alarm** fault (refer to *Reading the Display*), you can view information and reset (clear) current faults, as follows:

1. From the Main Menu, select **Fault List**, then select **Display Active Faults**. The following screen displays.

Faults are displayed in order of occurrence with the most recent fault at the top.

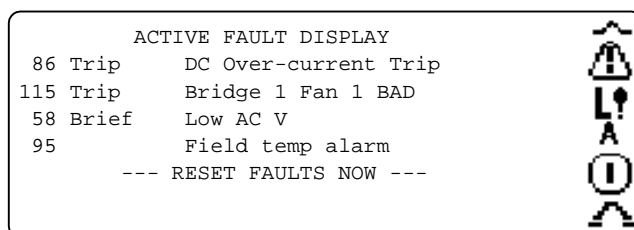

Refer to GEH-6633 *Troubleshooting, Preventive and Online Maintenance*, for a list of faults.

- To view **detail** on a particular fault, select that fault (listed on the Active Fault Display screen). The following screen displays.

```

SELECTED FAULT - PRESS
Low AC V, B
006:40:11.008
Low AC input volts detected on
the field exciter.

```



- Reset the faults **either** of two ways:
 - Select **Reset Faults Now** in the Fault Display screen.
 - Press the **Reset Faults** button.

➤ **To view the exciter's Fault History (a list of previously cleared faults and fault resets)**

- From the Main Menu, select **Fault List**, then select **Display Fault History**.

This display list may be multiple screens long.

```

FAULT HISTORY DISPLAY
0 Cleared   Fault reset
86 Trip     DC Over-current trip.
115 Trip    Bridge 1 Fan 1 BAD
58 Brief    Low AC V
95          Field temp alarm

--- RESET FAULTS NOW ---

```



Editing Parameters

There are two types of parameters that can be changed using the keypad:

- Option** parameters lists items (options) for you to select. For example, *True/False* is an option parameter.
- Numeric** parameters lists valid digits that you select to create a number.

➤ **To edit a parameter**

- From an exciter Parameters screen, select the parameter that is to be changed.

```

Parameters
GPT_Vrms           = <No Value>
VHiTripLev         = 1.2
AFFL                = 100
TripVHiTrip        = Trip enabled
VFFL                = 100
100.0

```



This displays either an Option or Numeric parameter screen (see both below) with the **New Value** line highlighted.

2. For an **Option** parameter:
 - a. Use the **Up** or **Down Arrow** buttons to select a new parameter value.
 - b. Press the **Enter** button to accept the change or **Escape** to exit and keep the present value.

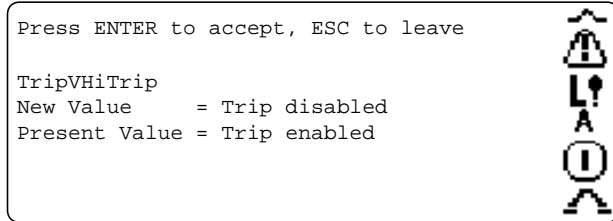

3. For a **Numeric** parameter:
 - a. Use the **Left** or **Right Arrow** buttons to highlight the digit to be changed.
 If you continue pressing the **Left Arrow** button after reaching the left-most digit of the edit field, the field fills with blanks. Pressing **Enter** when the entire number is blanked out saves a *<No Value>*.
 - b. Use the Up and Down Arrow buttons to index through the valid digits (0, 1, 2, 3, 4, 5, 6, 7, 8, 9, e, ., -).
 The *e* in the digit selection represents the start of the exponent in scientific notation. If the *e* is used, all digits to the right of the *e* make up the number's exponent.

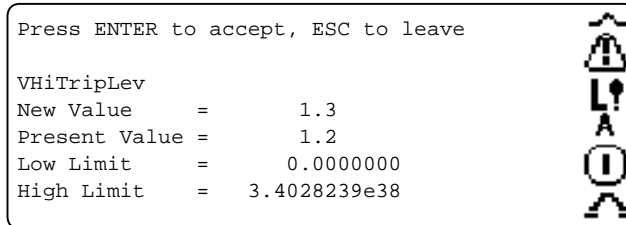

4. When all of the digits have been changed, press **Enter** to accept the new value or press **Escape** to exit and keep the present value.

Parameter Backup

It is good practice to keep a backup copy of the exciter's working parameter configuration. You can then restore this file, if needed, or compare it with a re-configured file to determine differences.

➤ To save active parameters

1. From the Main Menu, select **Parameter Backup Functions** then select **Save Parameters to Backup**.

Each new backup overwrites the previous backup copy, which cannot be restored.

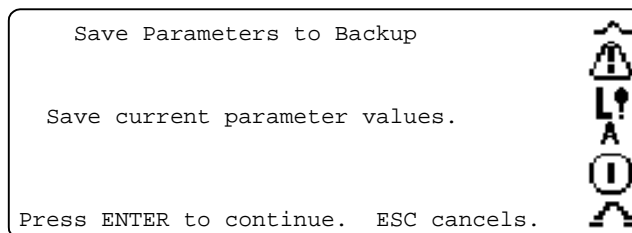

2. Press **Enter** to make a backup copy of the parameters or **Escape** to cancel.

➤ **To restore a parameter from backup**

1. Stop the exciter. (This function cannot be executed with the exciter running.)
2. From the Main Menu, select Parameter Backup Functions then select Restore Parameters from Backup.

```
Press to restore Parameters from Backup

-- WARNING --
The active parameter values will be
replaced, and can not be recovered.

Press ENTER to continue.  ESC cancels.
```

3. Press **Enter** to restore the backup parameters or **Escape** to cancel.



Restoring parameters from a backup file overwrites the currently active parameter values, which cannot then be restored.

Caution

➤ **To compare the active parameter set to the backup parameter set**

1. From the Main Menu, select **Parameter Backup Functions** then select **Compare Current Parameters to Backup**.

```
BACKUP DIFFERENCES      <More ↑ >
VHiTripLev              = 1.3
  Backup value           = 1.2
AFFL                     = 112.0
  Backup value           = 100.0
VFFL                     = 110.0
  Backup value           = 100.0
                        <More ↓ >
```



2. Use the **Up** and **Down Arrow** buttons to scroll through the list of backup differences.
3. Press **Escape** to return to the previous menu.

Firmware and Hardware Information

- **To view the firmware versions for the DSPX board and the keypad**

From the Main Menu select:

1. **General Setup**
2. **Firmware Version & Hardware Info**
3. **Display Firmware Version**

The following screen displays:

```
      GE Generator Control
      EX2100
DSPX Firmware Version:      V02.06.00B
DSPX Boot Monitor Version: V02.02.00C
DDI  Firmware Version:     V02.00.00B

Press ESC to exit
```



- **To view exciter hardware information**

From the Main Menu select:

1. **General Setup**
2. **Firmware Version & Hardware Info**
3. **Display Hardware Information**

The following screen displays:

```
      GE Generator Control
Hardware Information:
IS200ESELH1APR 5473716
IS215ACLAH1AL  8790070
IS200DSPXH1CAA 7611193
IS200EMIOH1APR 7360814
IS200EISBH1APR 5673766  <More ↓
ESC to exit
```



Protecting the Keypad

To protect the exciter from unauthorized operation or reconfiguration, the keypad includes two **security controls**, Password and Privilege Level.

The **Password** is a 5-digit number that protects the Password and Privilege Level from being changed by unauthorized personnel. The **default** Password is *00000*.

Privilege Level specifies which operational and configuration functions are disabled in the keypad. There are three levels:

- **Read Only** disables both the Exciter Control and the Configuration functions. An operator can view but not edit parameters.
- **Operate & Read Only** enables the Exciter Control function, but disables Configuration functions. An operator can view, but not edit parameters.
- **Configure & Operate** enables both the Exciter Control and the Configuration functions. This is the default setting.

If you try to execute a function that is disabled in the active Privilege Level, the keypad displays the following error message.

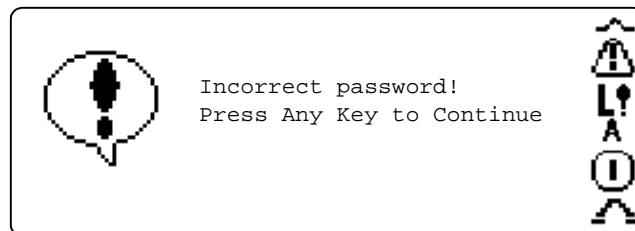

Modifying the Protections

➤ To modify the Password and Privilege Levels

1. From the Main Menu, select:
 - a. **General Setup**
 - b. **Keypad**
 - c. **Keypad Security**

The following screen displays:

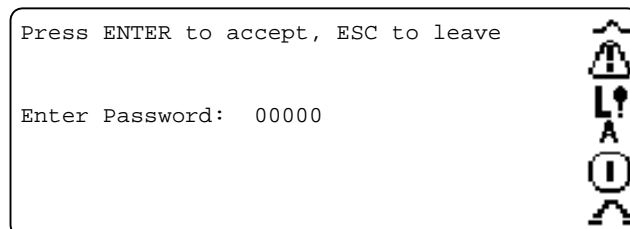

2. Enter the password as follows:
 - a. Use the **Up** and **Down Arrow** buttons to index through the valid digits (0 through 9).
 - b. Use the **Right** and **Left Arrow** buttons to move the cursor to the digit to edit.
 - Press **Enter** to accept the Password.
 - If the password that was entered matches the saved Password value, you can then modify the Privilege Level or Password.

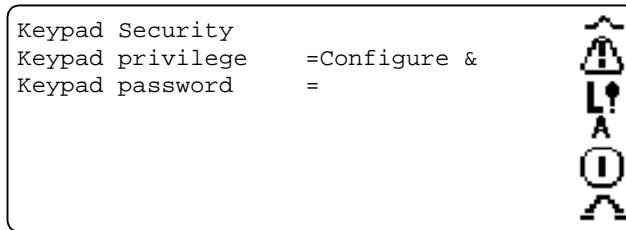

If it does not match, the keypad displays an error message.

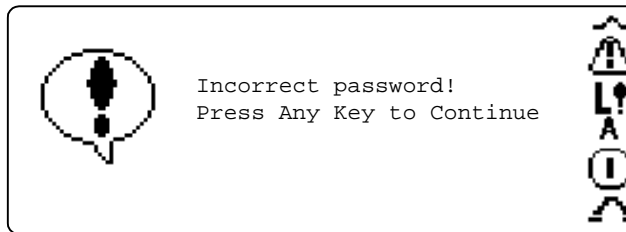

3. Use the **Up** and **Down Arrow** buttons to select either the Privilege Level or Password.
4. Press **Enter** to edit the parameter. (See *Editing Parameters*.)

Note When you modify the keypad password, be sure to select *Save Parameters To Backup*. Otherwise, the password stored in the active parameter will not match the backup parameter set. That causes the *Compare Current Parameters to Backup* to identify the Keypad Password parameter as different.

Notes

Appendix A Warranty and Renewal Parts

Introduction

When ordering a replacement part for a GE exciter, the customer needs to know:

- How to accurately identify the part
- If the part is under warranty
- How to place the order

This information helps ensure that GE can process the order accurately and as soon as possible.

To minimize system downtime if repair is needed, GE recommends that the customer keep a set of **spare parts** on hand. The *Renewal Parts Quotation* lists recommended spares.

Appendix A of this manual provides information to help the user identify and obtain replacement parts. It is organized as follows:

Section	Page
Identifying the Part	A-2
Renewal Parts List	A-2
Part Number Structure	A-2
Warranty Terms	A-4
How to Order Parts	A-5
Data Nameplate	A-5
ML Number	A-5

Identifying the Part

An exciter component, or part, is identified by its assigned **part number** and **description**. The part number is normally found on a nameplate on the component. The description is included in the system renewal parts list.

Renewal Parts List

The *Renewal Parts List* is a separate document that lists the parts of a **complete system**. This list applies specifically to the equipment furnished on a customer's particular application (requisition) at the time of shipment. It includes:

- Part numbers and descriptions
- Quantity used
- Recommended spares to keep onhand
- Normal delivery cycle for obtaining each part

GE provides the *Renewal Parts List* with the exciter's custom instructions. If this document is missing, contact the nearest GE sales office or service representative to obtain a replacement copy. You need to provide the following information (see Figure A-4) to correctly identify the system:

- Requisition number
- Model number

Part Number Structure

A GE part number is structured so that different portions of the number identify the **type of equipment** and **location of manufacture**. A part falls into one of four categories:

- Order-specific assemblies – Major assemblies or items that make up a specific exciter, constructed from common assemblies
- Common assemblies – Subassemblies used in many GE exciter products, not just a specific exciter
- Components – Individual parts that make up assemblies
- Printed wiring boards

These categories and the makeup of their part numbers are defined under *Order Specific Assemblies*.

Order Specific Assemblies

These parts make up the particular exciter. Other items obtained specifically for the order may also use a similar part number structure, which provides information about the equipment.

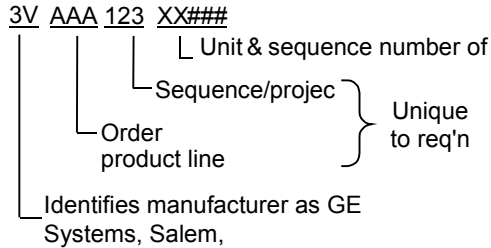

Sample Part Number for Order-Specific Assembly

Common Assemblies

Common assemblies are subassemblies used as components of order-specific assemblies. Common assemblies are not designed for a particular exciter, but provide a function used in other GE products.

For example, *36C774524AAG48* is the part number for a cable.

Components

Components are the **basic parts** that make up assemblies. They represent the lowest discrete level of a system. Component part numbers consist of a combination of alphanumeric characters that define the class and specific item. A sample number is shown below.

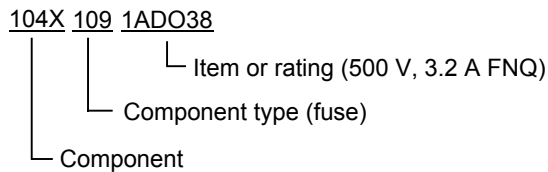

Sample Part Number for Component

Printed Wiring Boards

A printed wiring board is identified by an alphanumeric part (catalog) number stamped near its edge. The structure of a board's part number is described below.

Note All digits are important when ordering or replacing any board.

The factory may substitute later versions of boards based on availability and design enhancements. However, GE Industrial Systems ensures compatibility of replacement boards.

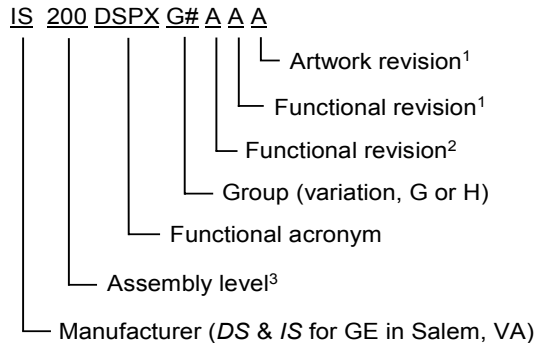

¹Backward compatible

²Not backward compatible

³200 indicates a base-level board; 215 indicates a higher-level assembly or added components (such as PROM)

Sample Board Part Number

Warranty Terms

The GE *Terms and Conditions* brochure details product warranty information, including **warranty period** and **parts and service coverage**. The brochure is included with customer documentation. It may be obtained separately from the nearest GE Sales Office or authorized GE Sales Representative.

Note Standard warranty is 18 months from shipment or 12 months from when power is first applied, whichever comes first.

How to Order Parts

("+" indicates the international access code required when calling from outside of the USA.)

Parts still under **warranty** may be obtained directly from the factory:

GE Industrial Systems
Product Service Engineering
1501 Roanoke Blvd.
Salem, VA 24153-6492 USA
Phone: + 1 800 533 5885 (United States, Canada, Mexico)
+ 1 540 378 3280 (International)
Fax: + 1 540 387 8606 (All)

Renewals (spares or those not under warranty) should be ordered by contacting the nearest GE Sales or Service Office. Be sure to include:

- Complete part number, located in the renewal parts list
- Part name
- Exciter model, located in it's nameplate

Data Nameplate

The data nameplate is located on the back of the cabinet door. It provides information needed when ordering parts or contacting GE for assistance.

ML Number

Each GE lineup, cabinet (panel)/case, and core unit has a unique identifying catalog number, also called the **part or material list (ML) number**. This number is structured to provide information about that equipment. The catalog number links the equipment to its requisition, drawings, components, materials, specification item, and shipping documents.

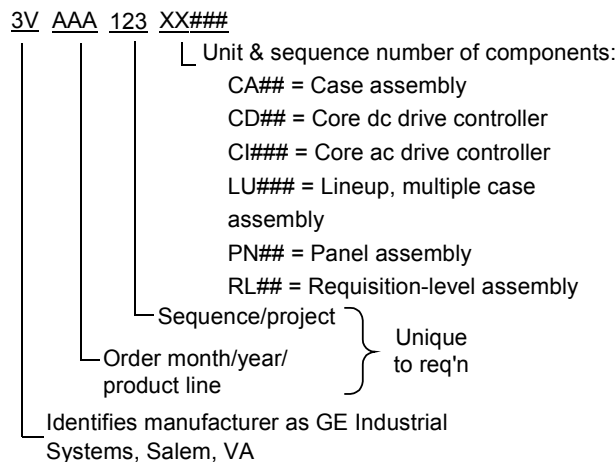

Sample Exciter ML (Catalog) Number

Notes

Appendix B Ratings and Specifications



Caution

The actual equipment rating is on your exciter nameplate. This appendix indicates the range of possible product offerings but not necessarily the capability of your exciter.

EX2100 Specification	Description
Power Conversion Module (PCM)	
Single bridge rating	1,000 and 2,000 A dc at up to 1,000 V ac
Parallel bridge rating	8,000 A dc at up to 1,500 V ac, with up to 6 bridges
Forcing requirements	150% of design Amperes (EDA) for 30 s at 40 °C
Power Sources	
Power for the PCM – Voltage source	Auxiliary bus Generator terminals Compound Source 600 or 1,000 V versions
Power for the PCM – VA (power)	3,251 KVA (1,000 V version)
Power for the PCM - Frequency	3-phase 50/60 Hz, ± 5%
Power to the Cooling Fans (3)	10 A rms, 125 V ac single source
Flashing power	125-250 V dc battery source, with up to 200 A for at least 10 s 380-480 V ac, 50/60 Hz single-phase auxiliary source
Control power (redundant with 2 bridges, warm backup}	For two ac sources, or one ac and one dc source Nominal 120 V ac ±15%, with 1 DACA, 10 A rms max. Battery source 125 V dc, range 80-140 V dc, 10.6 A dc max.
Heat loss in single PCM cabinet	10 KW for a 2000 A, 1,000 V ac PCM

Input/Output	QTY	
Potential transformers (PTs)	2	3-phase standard, single-phase available 120 V ac nominal 1 VA nominal burden
Current transformers (CTs, 1 or 5 A)	2	Any two phases, single phase is available 1 VA nominal burden
86G dedicated contact input	1	Open for trip
52G dedicated contact input	1	Closed for online
Trip rated contact outputs	2	At 125 V dc the relay break characteristics are: Resistive load 0.5 A Inductive load 0.2 A
General Purpose contact inputs	6	Customer contact, 70 V dc supplied by ECTB
General Purpose Form C contact outputs	4	At 125 V dc the relay break characteristics are: Resistive load 0.5 A Inductive load 0.1 A
± 10 V differential amplifier input	1	
Control		
Automatic ac Voltage Regulation		Proportional + Integral, software implemented ± 0.25 % over full voltage range
Manual dc Voltage regulator		Proportional + Integral, software implemented ± 2.0 % over full voltage range
Protection Features		Under Excitation Limiter, (UEL) Over Excitation protection (76) Generator Field Ground detection (64F) Generator Overvoltage protection (24G) Loss of Excitation protection (40) V/Hz limit (24) and trip (24T) Bridge Over Temperature (26) Field Over Temperature (49) Phase Unbalance (22) PT Failure (60)
Environmental Control & Protection		
Base controls cabinet		Continuous operation in a 0 to 40 °C ambient environment
Base power bridge and auxiliary cabinet		Continuous operation in a 0 to 40 °C ambient environment, with 5 to 95% humidity, non-condensing
Storage Temperature		-40 °C to +70 °C
Humidity		5 to 95% humidity, non-condensing
Altitude		Normal operation at 0 to 1000 m. Derate 6% per 1000 m above 1000 m
Cooling		Forced air cooling required for PCM cabinet
Contaminants, withstand 10 PPB of these:		Reactive Sulfur, Reactive Chlorine, Hydrogen Sulfide Sulfur Dioxide, Chlorine Dioxide, Sulfuric Acid Hydrochloric Acid, Hydrogen Chloride, Ammonia
Vibration		
Seismic		Universal Building Code (UBC) – Seismic Code section 2312 Zone 4
Shipping		72 hours at 0.3 G rms between 4 to 16 Hz 3 shocks of 15 G, 2 ms impulse for all three axes
Operating/Installed at Site		1.0 G Horizontal, 0.5 G vertical at 15 to 150 Hz

Cabinet Dimensions & Weight	
Redundant control with dual PCM redundant converter in a three-cabinet lineup	Width 141.74 in (3600 mm) Height 104.32 in (2650 mm) Depth 31.5 in (800 mm)
Weight of Converter cabinet	3,600 lbs.
Weight of Total Lineup (Converter, Control, and Auxiliary cabinets)	5,600 lbs.
Cabinet type, control & auxiliary	NEMA 1 (IEC IP 20), convection cooled
Cabinet type, power conversion	NEMA 1 (IEC IP 20), forced air cooled
Power and Control Cable Access	Entrances from the top and/or bottom
Reliability	
MTBF - Mean Time Between Failures	Simplex system 25,000 hrs
MTBF - Mean Time Between Failures	Redundant system 175,000 hrs
MTTR - Mean Time to Repair	Any subsystem 4 hrs
Acoustic	
Generated Acoustic Noise (Preliminary)	PCM cabinet approximately 75 dB
Codes and Standards	
UL 508C	Safety Standard Industrial Control Equipment
CSA 22.2 No. 14	Industrial Control Equipment
UL 796	Printed Wire Board Assemblies
ANSI IPC	Guidelines
IEC 801-2:1991	Electrostatic Discharge Susceptibility
ENV 50140:1993	Radiated RF Immunity
EN 50082-2:1994	Generic Immunity Industrial Environment
IEC 801-4	Electrical Fast Transient Susceptibility
IEC 1000-4-5	Surge Immunity
IEC 1000-4-6	Conducted RF Immunity
ENV 55011:1991	ISM Equipment Emissions
EN 61010-1	Safety of Electrical Equipment, Industrial Machines
IEC 529	Intrusion Protection Codes/NEMA 1/IP 20
IEEE 421.1	Standard Definitions for Excitation Systems for Synchronous machines
IEEE 421.2	Guide for Identification, Testing, and Evaluation of the Dynamic Performance of Excitation Control Systems
IEEE 421.3	High-Potential Test Requirements for Excitation Systems
IEEE 421.4	Guide for the preparation of Excitation Systems Specs
IEEE 421.5	Recommended Practice for Excitation Systems for Power Stability Studies
EN50178/LVD/EMC	CE Compliance
IEEE C57.12.01	General Requirements for Dry-Type Distribution & Power Transformers
IEEE C57.110	Recommended Practice for Establishing Transformer Capability when supplying Non-Sinusoidal Load Currents
IEEE C57.116	IEEE Guide for Transformers Directly Connected to Generators
IEEE C37.90.1	Surge Withstand Capability (SWC) tests for Protective Relays and Relay Systems
IEEE C57.18.10	Practices and Requirements for Semiconductor Power Rectifier Transformers

Notes

Glossary of Terms

6U

Full height Versa Module Eurocard (VME) board

application code

Software that controls the machine or process, specific to the application.

ASCII

American Standard Code for Information Interchange. An 8-bit code used for data.

auxiliary source

A source of three-phase ac power for the exciter, but not from the generator being controlled.

automatic voltage regulator (AVR)

AVR is controller software that maintains the generator terminal voltage through the Field Voltage Regulator.

baud

A unit of data transmission. Baud rate is the number of bits per second transmitted.

BIOS

Basic input/output system. Performs the controller boot-up, which includes hardware self-tests and the file system loader.

bit

Binary Digit. The smallest unit of memory used to store only one piece of information with two states, such as One/Zero or On/Off.

block

Instruction blocks contain basic control functions, which are connected together during configuration to form the required machine or process control. Blocks can perform math computations, sequencing, or regulator (continuous) control.

board

Printed wiring board or card.

bus

Upper bar for power transfer, also an electrical path for transmitting and receiving data.

bumpless

No disruption to the exciter when transferring control.

byte

A group of binary digits (bits); a measure of data flow when bytes per second.

CMOS

Complementary metal-oxide semiconductor.

COM port

Serial controller communication ports (two). COM1 is reserved for diagnostic information and the Serial Loader. COM2 is used for I/O communication

configure

To select specific options, either by setting the location of hardware jumpers or loading software parameters into memory.

crowbar

The crowbar limits the high negative voltages that can be induced into the PCM during a pole slip (loss of synchronism) event. It includes a discharge resistor, and is self firing.

CT

Current Transformer, used to measure current in an ac power cable.

DACA

Ac to dc converter for power supply, produces 125 V dc.

DCS (Distributed Control System)

Control system, usually applied to control of boilers and other process equipment.

de-excitation

The de-excitation circuit provides a conduction path through a discharge resistor to dissipate the field current after a unit trip.

device

A configurable component of a control system.

DRAM

Dynamic Random Access Memory, used in microprocessor-based equipment.

EGD

Ethernet Global Data, a control network and protocol for the controller. Devices share data through EGD exchanges (pages).

EMI

Electro-magnetic interference; this can affect an electronic control system.

EPBP Backplane

Exciter Power Backplane holds power supply modules, ground detect modules, and connectors for power distribution.

EPDM

Exciter Power Distribution Module distributes 125 V dc to the power supplies.

Ethernet

LAN with a 10/100 M baud collision avoidance/collision detection system used to link one or more computers together. Basis for TCP/IP and I/O services layers that conform to the IEEE 802.3 standard.

EX2100 Exciter

GE static exciter; regulates the generator field current to control the generator output voltage.

fanned input

A termination board input that is connected to all three redundant controllers.

fault code

A message from the controller to the HMI indicating a system warning or failure.

field flashing

The supply of initial exciter current during startup, usually from station batteries.

field ground detector

The field ground detector is an active circuit that detects a ground in either the ac or dc sections of the exciter and field wiring.

field voltage regulator (FVR)

FVR is controller software that maintains the generator terminal voltage using inputs from the Automatic Voltage Regulator (AVR) and the field voltage feedback.

firmware

The set of executable software that is stored in memory chips that hold their content without electrical power, such as EEPROM or Flash.

flash

A non-volatile programmable memory device.

FVR

Field Voltage Regulator, software controlling the voltage across the field.

gating

Controlling the conduction of the power SCRs with an input pulse train (or a voltage).

health

A term that defines whether a signal is functioning as expected.

heartbeat

A signal emitted at regular intervals by software to demonstrate that it is still active.

HMI

Human Machine Interface, usually a PC running Windows NT and CIMPLICITY HMI software.

hot backup

Two bridges are used but only one is connected to the field, the other (the backup) is connected to a small dummy load. If the active bridge fails it is disconnected from the field by relays, and the backup is connected.

ICS

Integrated Control System. ICS combines various power plant controls into a single system.

IEEE

Institute of Electrical and Electronic Engineers. A United States-based society that develops standards.

I/O

Input/output interfaces that allow the flow of data into and out of a device.

I/O drivers

Software that interfaces the controller with input/output devices, such as communication networks, sensors, and solenoid valves.

IP address

The address assigned to a device on an Ethernet communication network.

line filter

Filter networks across the three-phase input lines to the exciter to minimize the voltage spikes that result from the abrupt decay of current during SCR commutations.

LCI Static Starter

Electric power device that runs the generator as a motor to bring a gas turbine up to starting speed.

logical

A statement of a true sense, such as a Boolean.

Mark VI turbine controller

A control system hosted in one or more VME racks that performs turbine-specific speed control, logic, and sequencing.

Modbus

A serial communication protocol developed by Modicon for use between PLCs and other computers.

multiple bridges

Several power producing bridges operate in parallel to produce a high field current. These share the exciter current load to provide redundancy and increased reliability.

NEMA

National Electrical Manufacturers Association; a U.S. standards organization.

non-volatile

Memory specially designed to store information even when the power is off, for example Flash memory.

OLR

On-Line Repair, capability provided by redundant control elements.

over-excitation limiter (OEL)

OEL software limits the excitation current to prevent overfluxing the generator

power conversion module (PCM)

The PCM or Bridge consists of six three-phase rectifiers, with associated protection and control devices, to generate the dc field current.

power current transformer (PCT)

A PCT can be attached to the generator line to provide a portion of the three-phase power for the exciter, part of a compound source.

power distribution module (EPDM)

The PDM distributes 125 V dc to the power supplies for the controllers and I/O termination boards.

power potential transformer (PPT)

A PPT is attached to the generator terminals to provide three-phase power for the exciter; referred to as a potential source.

power system stabilizer (PSS)

PSS software produces a damping torque on the generator to reduce generator oscillations.

product code (runtime)

Software stored in the controller's Flash memory that converts application code (pcode) to executable code.

PRV

Peak Reverse Voltage is limited with pole slip resistors, wired across the SCRs.

PT

Potential Transformer, used for measuring voltage in a power cable.

real-time

Immediate response, referring to control systems that must respond instantly to changing conditions.

reboot

To restart the controller or toolbox.

Redundant

A system consisting of duplicated components (boards or modules), which can transfer functionality from a failed component to one of the duplicate components without loss of the entire system's functionality.

relay ladder diagram (RLD)

A ladder diagram represents a relay circuit. Power is considered to flow from the left rail through contacts to the coil connected at the right.

RFI

Radio Frequency Interference; this is high frequency electromagnetic energy which can affect the control system.

RTD

Resistance Temperature Device, used for measuring temperature.

runtime

See product code.

runtime errors

Controller problems indicated on the front panel by coded flashing LEDs, and also in the Log View of the toolbox.

sampling rate

The rate at which process signal samples are obtained, measured in samples/second.

serial loader

Connects the controller to the toolbox PC using the RS-232C COM ports. The Serial Loader initializes the controller flash file system and sets its TCP/IP address to allow it to communicate with the toolbox over Ethernet.

server

A PC, which gathers data over Ethernet from plant devices, and makes the data available to PC-based operator interfaces known as Viewers.

shaft voltage suppressor

The shaft voltage suppressor is a filter that conducts to ground the high frequency components of the induced voltages in the field current.

signal

The basic unit for variable information in the controller.

simplex

System with only one set of control and I/O boards. Contrast with redundant control systems.

simulation

Running the control system using a software model of the generator and exciter.

SOE

Sequence of Events, a high-speed record of contact closures taken during a plant upset to allow detailed analysis of the event.

Static Exciter

Produces a controlled dc field current without the use of a rotating generator.

TCP/IP

Communications protocols developed to inter-network dissimilar systems. It is a de facto UNIX standard, but is supported on almost all systems. TCP controls data transfer and IP provides the routing for functions.

TMR

Triple Modular Redundancy. An operation that uses three sets of control and I/O (channels M1, M2, and C) and votes the results.

toolbox

A Windows NT -based software package used to configure the EX2100 and Mark VI turbine controller.

under-excitation limit (UEL)

UEL software functions to prevent generator over-heating caused by under excitation.

unit data highway (UDH)

Connects the EX2100, Mark VI turbine controllers, LCI, PLCs, and other GE provided equipment to the HMI Servers; runs at 10/100 Mbaud and supports Peer-to-Peer communications.

V/Hz

V/Hz is the ratio of generator voltage to the frequency; this is limited to prevent overfluxing the generator.

VME board

Versa Module Eurocard, a European standard for printed circuit boards and backplane.

warm backup

Two bridges are connected to the field but only one is actively producing power. The other bridge does not receive gating pulses until it is required to take over from the active bridge.

Windows NT

Advanced 32-bit PC operating system from Microsoft.

Notes

Index

A

ac disconnect 1-5, 2-5
Ac Line-to-Line Filters 2-1, 2-8
Ac to Dc Converter 1-6, 2-14, 3-1, 3-9, 3-11, B-1
ACLA (see Application Control Layer Module)
Analog I/O 4-1, 4-2
Analog Input 4-1, 4-3
Application Control Layer Module 1-6, 2-11, 2-13, 2-14, 3-1, 3-2, 3-4, 4-19, 4-20
AUTO REF (see Auto Reference)
Auto Reference 2-1, 2-20
Automatic Voltage Regulator 2-1, 2-20, 2-21, 3-4
auxiliary cabinet 1-5, 1-7, 2-5, 2-8, 2-15, 4-7, B-2
Auxiliary Cabinet 2-1, 2-8, 3-9, 4-16
 Ac Line-to-Line Filters 2-1, 2-8
 De-excitation Module 2-1, 2-8, 3-1, 3-6 – 3-8, 3-10, 3-11, 4-11
 Field Flashing Module 2-1, 2-9
 Field Ground Detector 2-1, 2-9, 3-7, 4-1, 4-14, 4-15
 High Voltage Interface 2-1, 2-9
 Shaft Voltage Suppressor 2-1, 2-9, 4-1, 4-18
Auxiliary power source 2-2
AVR (see Automatic Voltage Regulator)
AVR Setpoint 2-1, 2-20

B

bridge 1-2, 1-5, 1-6, 2-2, 2-5 – 2-9, 2-11, 2-14, 2-19, 3-1, 3-2, 3-5 – 3-7, 4-3, 4-8, 4-9, 4-16, B-1, B-2
Bridge and Protection Boards and Modules
 EDEX 2-1, 2-8, 3-1, 3-6 – 3-8, 3-10, 3-11, 4-11
 EGDM 2-1, 2-9, 2-15, 3-1, 3-4, 3-7 – 3-11, 4-14
 EGPA 2-1, 2-5, 2-6, 2-11, 2-14, 3-1, 3-4, 3-5, 3-7, 3-9
 EXAM 2-1, 2-9, 2-15, 3-1, 3-7 – 3-10
 EXCS 3-1, 3-7
Bridge Rectifier 2-5

C

Cabinet Dimensions & Weight 1-7, B-3

Cell Snubbers 2-5
communication 1-2, 1-5, 2-11, 2-13, 3-4, 4-19, 4-20, 5-6
Compound power source 2-2
contact input 1-7, 3-4 – 3-6, 4-4, B-2
contact output 1-7, 3-5, 3-6, 4-4, B-2
control 1-1, 1-2, 1-5 – 1-7, 2-1 – 2-4, 2-6, 2-8 – 2-11, 2-13, 2-14, 2-17, 2-19, 2-20, 2-21, 3-1, 3-2, 3-4 – 3-9, 3-11, 4-3, 4-4, 4-8, 4-11, 4-14, 4-16, 4-19, 5-1, 5-2, B-3
Control Boards
 ACLA 1-6, 2-11, 2-13, 2-14, 3-1, 3-2, 3-4, 4-19, 4-20
 DSPX 1-6, 2-11, 3-1, 3-2, 3-4, 3-8, 4-14, 4-20, 5-13
 EBKP 3-1, 3-2, 3-6, 3-11, 4-8
 EISB 2-11, 3-1, 3-2, 3-4, 3-6, 3-8, 4-8
 EMIO 2-11, 3-1, 3-2, 3-4 – 3-6, 4-3, 4-4, 4-16, 4-17
 ESEL 2-6, 2-11, 2-14, 3-1, 3-2, 3-4, 3-5, 3-7
control cabinet 1-5, 2-9, 2-10, 3-11, 4-3
Control Cabinet 2-1, 2-10
 Control Module 2-1, 2-11
 Control Power Supplies 2-1, 2-14
 Diagnostic Interface 1-1, 2-1, 2-2, 2-10, 5-1
 Redundant Control System 2-1, 2-13
 Simplex Control System 2-1, 2-12
control module 1-2, 2-6, 2-11, 2-14, 3-4, 4-14, 4-16
Control Module 2-1, 2-11
Control power supplies 2-2
Control Power Supplies 2-1, 2-14
Control Scheme 2-18
Control System Toolbox 1-2, 1-6, 1-8, 2-2, 2-17, 4-1, 4-20
 Connection 4-1, 4-20
Controller
 C 1-2, 2-11, 2-13, 2-14, 3-2, 3-4, 3-5, 3-7 – 3-9, 3-11, 4-3, 4-14, 4-20,
 M1 1-2, 2-11, 2-13, 2-14, 3-2, 3-4, 3-5 – 3-9, 3-11, 4-3, 4-14, 4-20
 M2 1-2, 2-11, 2-13, 2-14, 3-2, 3-4, 3-5 – 3-9, 3-11, 4-3, 4-14, 4-20
cooling fans 1-5, 2-2, 3-9
Crowbar 2-2, 3-6, 3-7, 3-10, 3-11, 4-1, 4-14, 4-18
Crowbar module 2-2, 3-7, 3-11
Current Shunt 2-6
Current transformers 1-7, B-2
Customer Contact I/O 4-1, 4-4

- De-Excitation 3-7, 3-11, 4-1, 4-11 – 4-13
 - Crowbar 2-2, 3-6, 3-7, 3-10, 3-11, 4-1, 4-14, 4-18
 - Field Flashing 2-1, 2-9, 3-2, 4-1, 4-16, 4-17
 - Field Ground Detector 2-1, 2-9, 3-7, 4-1, 4-14, 4-15
 - Shaft Voltage Suppressor 2-1, 2-9, 4-1, 4-18
- De-excitation module 2-2, 2-8
- De-excitation Module 2-1, 2-8, 3-1, 3-6 – 3-8, 3-10, 3-11, 4-11
- Diagnostic Interface 1-1, 2-1, 2-2, 2-10, 5-1
 - Alternate Status Screen 5-1, 5-8
 - Changing Display 5-1, 5-7
 - Editing Parameters 5-1, 5-10, 5-15
 - Faults 5-1, 5-9
 - Keypad 2-10, 5-1
 - Protecting the Keypad 5-1, 5-14
 - Reading the Display 5-1, 5-5, 5-9
 - Reading the Meters 5-1, 5-8
 - Status Screen 5-1, 5-3, 5-5, 5-8
 - Using the Menus 5-1, 5-9
 - Using the Pushbuttons 5-1, 5-2
- Diagnostic Interface (keypad) 1-1, 2-1, 2-2, 2-10, 3-2, 3-4, 5-1, 5-2, 5-5, 5-6, 5-8, 5-9, 5-10, 5-13 – 5-15
- Digital Signal Processor Control Board 1-6, 2-11, 3-1, 3-2, 3-4, 3-8, 4-14, 4-20, 5-13
- Document Distribution 1-1, 1-8
- DSPX (see Digital Signal Processor Control Board)
- Dual Control System Configurations 2-4

E

- EACF (see Exciter AC Feedback Board)
- EBKP (see Exciter Backplane)
- ECTB (see Exciter Contact Terminal Board)
- EDCF (see Exciter DC Feedback Board)
- EDEX (see De-excitation Module)
- EDEX (see Exciter De-excitation Board)
- EGDM (see Exciter Field Ground Detector Module)
- EGPA (see Exciter Gate Pulse Amplifier Board)
- EISB (see Exciter ISBus Board)
- EMIO (see Exciter Main I/O Board)
- EPBP (see Exciter Power Backplane)
- EPCT (see Exciter PT/CT Board)
- EPDM (see Exciter Power Distribution Module)
- EPSM (see Exciter Power Supply Module)
- ESEL (see Exciter Selector Board)
- Ethernet 1-2, 2-11, 2-13, 3-4, 3-10, 4-19, 4-20
- EXAM (see Exciter Attenuator Module)
- EXASP (see AVR Setpoint)
- Exciter AC Feedback 3-5, 3-7, 3-11, 4-1, 4-7, 4-8
- Exciter AC Feedback Board 2-9, 3-1, 3-4, 3-5, 3-7, 4-3, 4-8
- Exciter Attenuator Module 2-1, 2-9, 2-15, 3-1, 3-7 – 3-9, 3-10
- Exciter Backplane 3-1, 3-2, 3-6, 3-11, 4-8
- Exciter Conduction Sensor Board 3-1, 3-7
- Exciter Configurations 2-1, 2-3

- Exciter Contact Terminal Board 1-7, 2-15, 3-1, 3-4 – 3-6, 3-10, 3-11, 4-4, B-2
- Exciter DC Feedback 3-5, 3-6, 3-11, 4-1, 4-8
- Exciter DC Feedback Board 2-6, 2-9, 2-13, 3-1, 3-4 – 3-6, 3-10, 3-11, 4-8
- Exciter Gate Pulse Amplifier Board 2-1, 2-5, 2-6, 2-11, 2-14, 3-1, 3-4, 3-5, 3-7, 3-9
- Exciter Internal I/O 4-1, 4-8
 - Exciter AC Feedback 3-5, 3-7, 3-11, 4-1, 4-7, 4-8
 - Exciter DC Feedback 3-5, 3-6, 3-11, 4-1, 4-8
 - Field Current Feedback 4-9
 - Field Voltage Feedback 4-9
- Exciter ISBus Board 2-11, 3-1, 3-2, 3-4, 3-6, 3-8, 4-8
- Exciter Main I/O Board 2-11, 3-1, 3-2, 3-4 – 3-6, 4-3, 4-4, 4-16, 4-17
- Exciter Power Backplane 2-14 – 2-16, 3-1, 3-8, 3-9, 3-11
- Exciter Power Distribution Module 2-14, 2-16, 3-1, 3-7, 3-9, 3-11, 4-6
- Exciter Power Supply Module 2-12, 2-14, 3-1, 3-9, 3-11
- Exciter PT/CT Board 2-13, 2-17, 3-1, 3-4, 3-5, 4-3
- Exciter Selector Board 2-6, 2-11, 2-14, 3-1, 3-2, 3-4, 3-5, 3-7
- Exciter Software
 - Auto Reference 2-1, 2-20
 - Automatic Voltage Regulator 2-1, 2-20, 2-21, 3-4, 5-4
 - AVR Setpoint 2-1, 2-20
 - Field Current Regulator 2-1, 2-21, 3-2
 - Field Voltage Regulator 2-1, 2-20, 2-21, 3-2, 5-4, 5-8
 - Manual Reference 2-1, 2-21
 - Power System Stabilizer 2-1, 2-17, 2-20, 3-4
 - Under Excitation Limiter 2-1, 2-20, 3-4, 5-6, B-2
- Exciter Terminal Board 2-7, 2-14, 2-15, 3-1, 3-4 – 3-6, 3-8 – 3-11, 4-11, 4-16, 4-17
- EXCS (see Exciter Conduction Sensor Board)
- EXTB (see Exciter Terminal Board)

F

- FCR (see Field Current Regulator)
- Field Current Feedback 4-9
- Field Current Regulator 2-1, 2-21, 3-2
- field flashing 1-5, 2-8, 2-9, 3-4, 3-6, 4-16
- Field flashing module 2-2
- Field Flashing Module 2-1, 2-9
- Field Ground Detector 2-1, 2-9, 3-7, 4-1, 4-14, 4-15
- Field Ground Detector Module 2-1, 2-9, 2-15, 3-1, 3-4, 3-7 – 3-11, 4-14
- Field Voltage Feedback 4-9
- Field Voltage Regulator 2-1, 2-20, 2-21, 3-2, 5-4, 5-8
- Flashing Control 4-1, 4-16
- Free Wheeling Diode 2-1, 2-7
- FVR (see Field Voltage Regulator)

G

Gate Pulse Amplifiers 2-1, 2-6
Generator Current Measurement 4-3
Generator Voltage Measurement 4-3

H

Hardware
 Overview 1-1, 1-5
High Voltage Interface 2-1, 2-9
HMI
 Mark VI 2-1
 Toolbox 2-1, 4-20
HMI (see Human Machine Interface)
How to Get Help 1-1, 1-8
Human Machine Interface 1-2, 2-1, 2-20, 2-21, 3-4, 4-19
 Mark VI 2-1
 Toolbox 2-1, 4-20
HVI (see High Voltage Interface)

I

I/O 1-1, 1-5, 1-6, 2-2, 2-10, 2-11, 3-1, 3-2, 3-4, 3-5, 3-9, 3-11, 4-1, 4-5, 5-1, 5-8
I/O Terminal Boards
 EACF 2-9, 3-1, 3-4, 3-5, 3-7, 4-3, 4-8
 ECTB 1-7, 2-15, 3-1, 3-4 – 3-6, 3-10, 3-11, 4-4, B-2
 EDCF 2-6, 2-9, 2-13, 3-1, 3-4 – 3-6, 3-10, 3-11, 4-8
 EPCT 2-13, 2-17, 3-1, 3-4, 3-5, 4-3
 EXTB 2-7, 2-14, 2-15, 3-1, 3-4 – 3-6, 3-8 – 3-11, 4-11, 4-16, 4-17

K

Keypad 1-1, 2-10, 5-2, 5-7, 5-14, 5-15

L

Leg Reactors 2-5
Line Filter Connections 4-1, 4-7
Line-to-line filters 2-2

M

Main Dc Contactors 2-1, 2-7
Manual Ac Disconnect 2-1, 2-5
MANUAL REF (see Manual Reference)
Manual Reference 2-1, 2-21
Mark VI HMI 2-1
Microprocessor-based controllers
 ACLA 1-6, 2-11, 2-13, 2-14, 3-1, 3-2, 3-4, 4-19, 4-20
 DSPX 1-6, 2-11, 3-1, 3-2, 3-4, 3-8, 4-14, 4-20, 5-13
Multibridge configuration 2-2

O

operator interface 1-2, 2-10

P

PCM (see Power Conversion Module)
Potential transformers 1-7, B-2
Power Connections 4-1, 4-2
power conversion cabinet 1-5, 2-8
Power Conversion Cabinet 2-1, 2-5, 4-11
 Free Wheeling Diode 2-1, 2-7
 Gate Pulse Amplifiers 2-1, 2-6
 Main Dc Contactors 2-1, 2-7
 Manual Ac Disconnect 2-1, 2-5
 Power Converter Module 1-6, 2-1, 2-5
power conversion module 1-2, 1-6, 1-7, 2-1, 2-2, 2-5, 3-5, 3-7, 4-14, B-1 – B-3
Power Conversion Module 1-2, 1-6, 1-7, 2-1, 2-2, 2-5, 3-5, 3-7, 4-14, B-1, B-2, B-3
Power Converter Module 1-6, 2-1, 2-5
Power potential transformer 1-2, 2-2, 2-5, 2-9, 3-7, 4-3, 4-14
Power Potential Transformer 4-1, 4-3
power source 1-2, 3-7
Power Supply Boards
 DACA 1-6, 2-14, 3-1, 3-9, 3-11, B-1
 EPBP 2-14 – 2-16, 3-1, 3-8, 3-9, 3-11
 EPDM 2-14, 2-16, 3-1, 3-7, 3-9, 3-11, 4-6
 EPSM 2-12, 2-14, 3-1, 3-9, 3-11
Power Supply Inputs 4-1, 4-6
Power System Stabilizer 2-1, 2-17, 3-4
PPT (see Power potential transformer)
PPT (see Power Potential Transformer)
PSS (see Power System Stabilizer)

R

RAM 1-6
Ratings and Specifications 1-1
Redundant ac source 2-2
Redundant Control System 2-1, 2-13
Related Documents 1-1, 1-8

S

SCR 1-2, 1-5, 2-5 – 2-8, 3-2, 3-5 – 3-8, 4-8, 4-9, 4-11
SCR De-excitation Module 2-8
shaft voltage suppression 1-5, 2-8
Shaft voltage suppressor 2-2
Shaft Voltage Suppressor 2-1, 2-9, 4-1, 4-18
Simplex Control Configurations 2-3
Simplex Control System 2-1, 2-12
Software
 Overview 1-1, 1-6
Status Screen 5-1, 5-3, 5-5, 5-8

T

Technical Characteristics 1-1, 1-6
Thyrite 2-8, 4-18
TMR (see Triple Modular Redundant)
Toolbox (see Control System Toolbox)
Triple Modular Redundant 2-2, 2-14

U

UDH (see Unit Data Highway)
UEL (see Under Excitation Limiter)
Under Excitation Limiter 2-1, B-2
Unit Data Highway 1-2, 4-19

W

Warm backup bridge configuration 2-2
Warranty and Renewal Parts 1-1, A-1



GE Industrial Systems

+ 1 540 387 7000
www.GEindustrial.com

General Electric Company
1501 Roanoke Blvd.
Salem, VA 24153-6492 USA